



PASSION FOR CREATING SPACES



PCA was founded in 2008 and it is a member of PAP GROUP, located in the Industrial Area of Thessaloniki in a plant of 14000m², owned by the group. Company's main activity is designing and manufacturing glass accessories and aluminium profiles aiming to provide complete solutions to every glass application. Company's principals are quality, innovation, excellent service and competitive prices. PCA also has a Research & Development (R & D) department of innovative products burdened with the study, design and optimization of components available to the company.

For the period 2012 - 2018, 80% of the company turnover occurred in exports worldwide in 50 countries. The product range of the company covers the following types of structures:

| Shower Cabins | Facades | Folding Doors
| Internal Doors | Sliding Doors | Glass Wall Partitions
| Glass Canopies | Glass Railings | Spider Systems
| Glass Staircases



PAP SAFETY GLASS
PAPGROUP





Index

Shower Cabins & WC Partitions

SX	NEW softclose sliding shower cabin series	09
SN	sliding shower cabin series	14
SA	sliding shower cabin series	18
A0	opening shower cabin series	22
B0	opening shower cabin series	28
WN	opening shower cabin series	34
ST09	opening shower cabin series	36
SA09	opening shower cabin series	38

Sliding Doors & Office Partitions

D	sliding door series with soft close	82
B	sliding door series	86
SA	sliding door series	90
V1000	telescopic synchronized door	94
V2000	sliding door series with soft close	98
A1	door frame series	116
A2	door frame series	117
A3	door frame series	118
A4	door frame series	119
A5	NEW door frame series	120
A21	full door frame series	128
A22	full door frame series	129
A23	full door frame series	130
A24	full door frame series	131
A25	NEW full door frame series	132
A8	partition series	138
A9	partition series	140
A10	partition series	142
A11	partition series	146

Facades

WR1	facade series	170
WR2	facade series	172
WS1	facade series	174
W1	partition series	178
W2	partition series	180

Folding Doors

DR01	folding door series (parking)	200
DR02	folding door series (hinge)	202

Guillotine

GL	NEW guillotine series	210
-----------	------------------------------	-----

Spiders

S1	spider series	216
S2	spider series	218

Balcony Railings

M1	balcony railing series	228
M2	balcony railing series	230
M3	balcony railing series	232
M10	balcony railing series	234
M11	balcony railing series	236
M12	balcony railing series	238
M17	NEW balcony railing series	240
M18	NEW balcony railing series	242
M19	NEW balcony railing series	244
M4	balcony railing series	248
M13	balcony railing series	250
M14	lateral point fixing series	252
M20	NEW lateral point fixing series	254
M16	lateral point fixing series	256
M15	lateral point fixing series	258
M9	lateral point fixing series	260
M21	NEW lateral point fixing series	261
M22	NEW lateral point fixing series	262
M6	lateral point fixing series	264
M7	lateral point fixing series	268
M8	lateral point fixing series	270

Inox Railings

NX	NEW Inox railings series	275
-----------	---------------------------------	-----

Staircase

L1	Staircase series	294
-----------	------------------	-----

Canopies

E1	Canopy series	298
E2	Canopy series	302
E3	Canopy series	305

Miscellaneous & Consumables

307

Shower Cabins & WC Partitions	8
Doors & Office Partitions	81
Facades	169
Folding	199
Guillotine	209
Spiders	215
Balcony Railings	225
Inox Railings	273
Staircase	293
Canopies	297
Miscellaneous & Consumables	307

SHOWER CABINS

SHOWER CABIN SERIES | **SX**



NEW

SOFTCLOSE

NEW



1 x GT07



2 x HL48



2 x RH50



2 x SP17



1 x GG19



1 x GG21



1 x S05



1 x S06



1 x FG06



1 x DK08
(Optional)



SX01 CABIN

OPTIONAL KNOBS ► 74 - 75

•OPTIONAL **U** GG15,GG14,GG19 for **8mm** Glass Thickness

GLASS PREPARATION

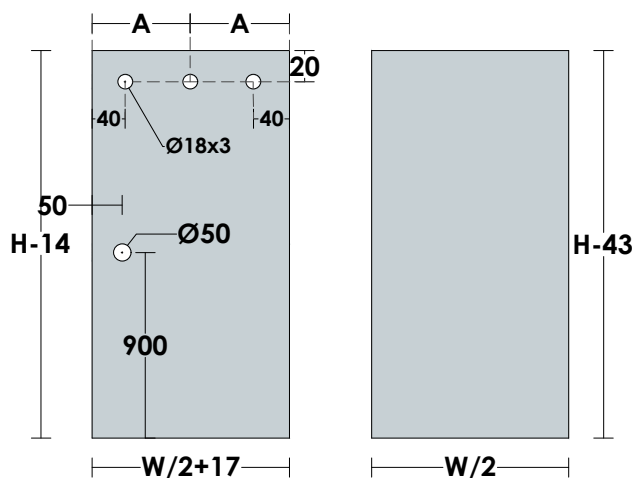

TOP VIEW DETAIL

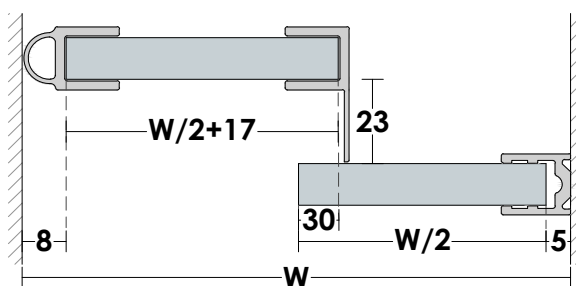

NEW



1 x GT07



1 x HL49



1 x HL48



2 x RH50



2 x SP17



1 x GG19



1 x GG21



1 x S09



2 x S06



1 x FG06



1 x FG10



1 x DK08
(Optional)



SHOWER CABIN

SX03 CABIN

OPTIONAL KNOBS ▶ 74 - 75

•OPTIONAL U GG15,GG14 for 8mm Glass Thickness

GLASS PREPARATION

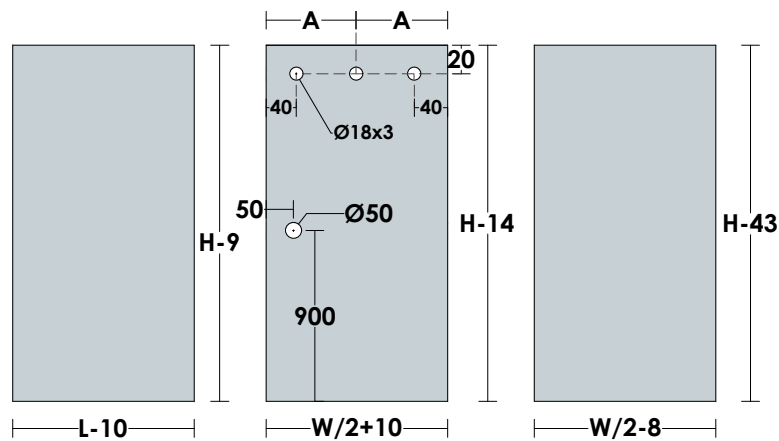

TOP VIEW DETAIL

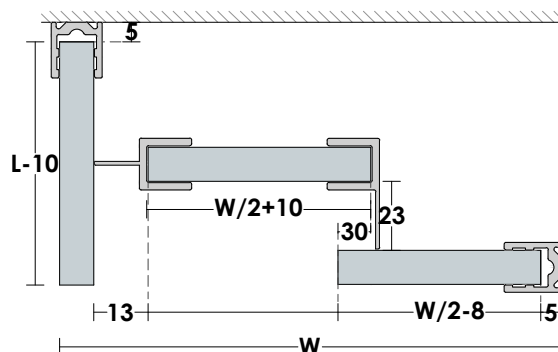



NEW

NEW



- 1 x GT07 
- 1 x HL50 
- 2 x HL48 
- 4 x RH50 
- 4 x SP17 
- 2 x GG19 
- 1 x GG21 
- 1 x S09 
- 2 x S06 
- 1 x FG07 
- 2 x FG06 
- 2 x DK08 (Optional) 

SX02 CABIN

•OPTIONAL **U** GG15,GG14 for **8mm** Glass Thickness

OPTIONAL KNOBS ► 74 - 75

SHOWER CABIN

GLASS PREPARATION

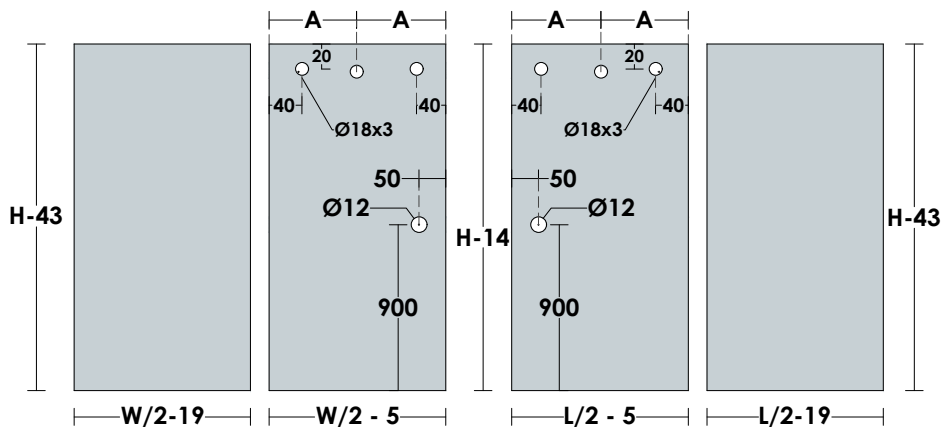

TOP VIEW DETAIL

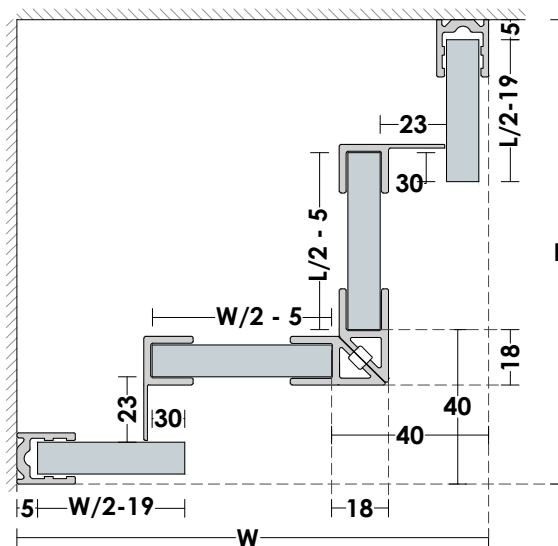



SHOWER CABIN SERIES | **SN**

SHOWER CABIN

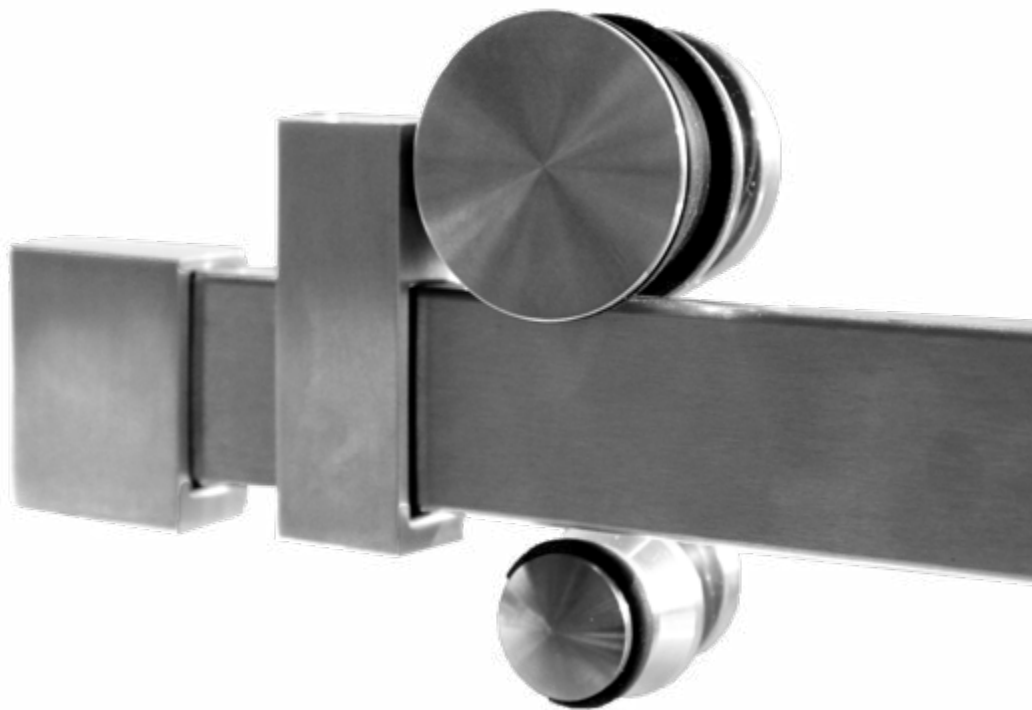



SN01 CABIN

1 x PCA SN - Kit

- 2 x RH18 
- 2 x RH18B 
- 2 x HL39 
- 2 x HL34 
- 2 x SP14 

- 1 x GT02 
- 1 x GG01 
- 1 x GG15 
- 1 x GG02 
- 1 x S05 
- 1 x S06 
- 1 x FG01 
- 1 x DK08 (Optional) 

•OPTIONAL **U** GG15,GG14 for **8mm** Glass Thickness
GG03 for **10mm** Glass Thickness

OPTIONAL KNOBS ► 74 - 75

GLASS PREPARATION

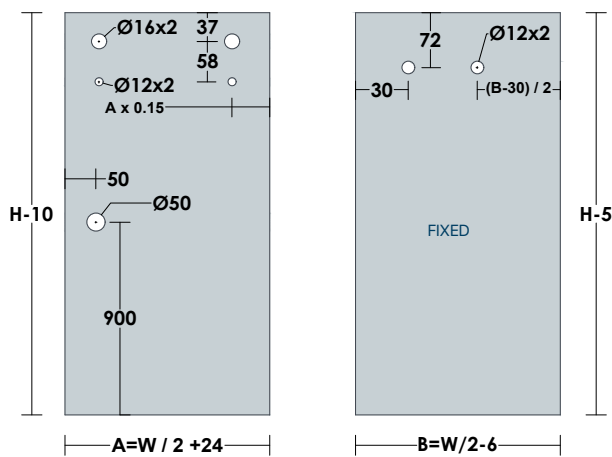

TOP VIEW DETAIL

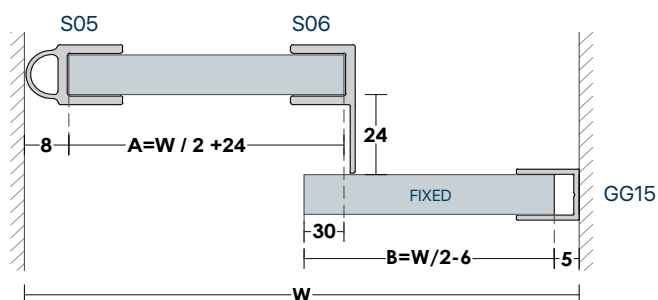





SN02 CABIN

•OPTIONAL U GG15,GG14 for 8mm Glass Thickness
GG03 for 10mm Glass Thickness

2 x PCA SN - Kit

- 2 x RH18 
- 2 x RH18B 
- 2 x HL39 
- 2 x HL34 
- 2 x SP14 

- 1 x FG03 
- 1 x HL35 

- 1 x GT02 
- 1 x GG01 
- 2 x GG15 
- 1 x GG02 
- 1 x S09 
- 2 x S06 
- 2 x FG01 
- 2 x DK08 (Optional) 

OPTIONAL KNOBS ► 74 - 75

GLASS PREPARATION

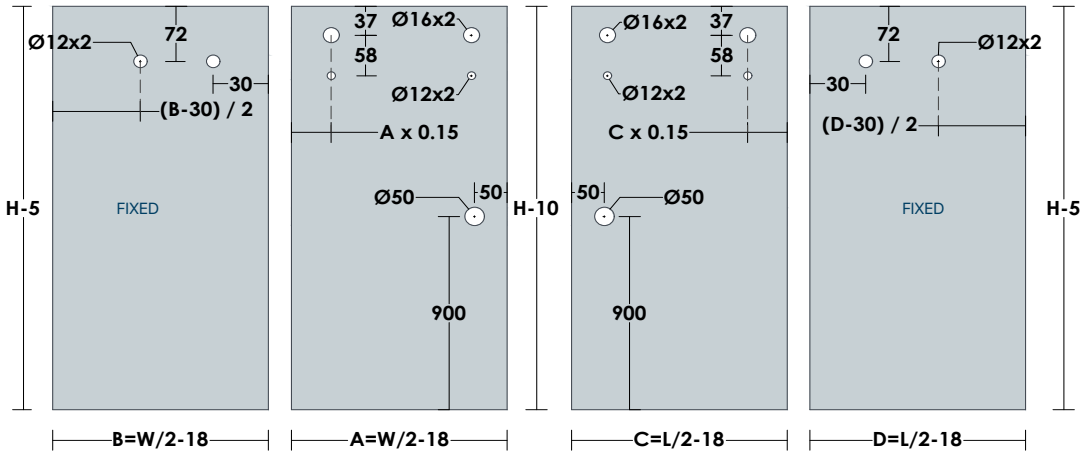

TOP VIEW DETAIL

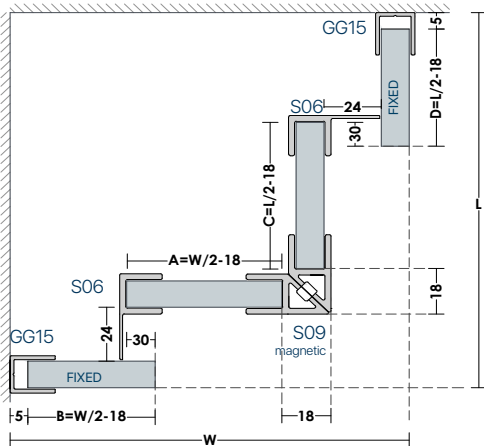



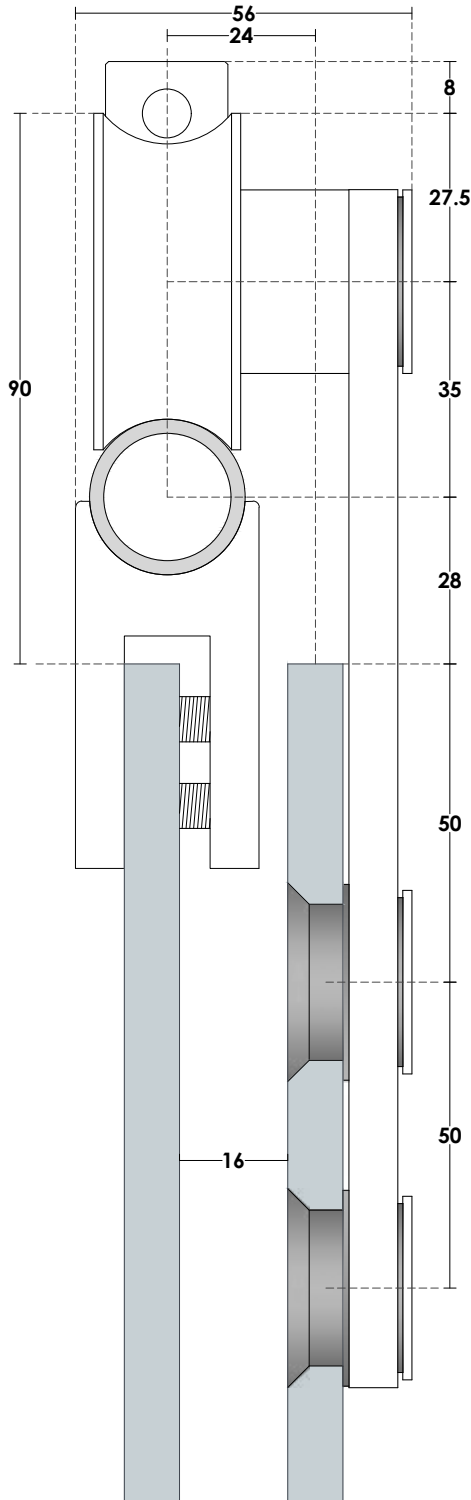



SA01 CABIN



•OPTIONAL **U** GG09 for **10mm** Glass Thickness

OPTIONAL KNOBS ► 74 - 75

GLASS PREPARATION

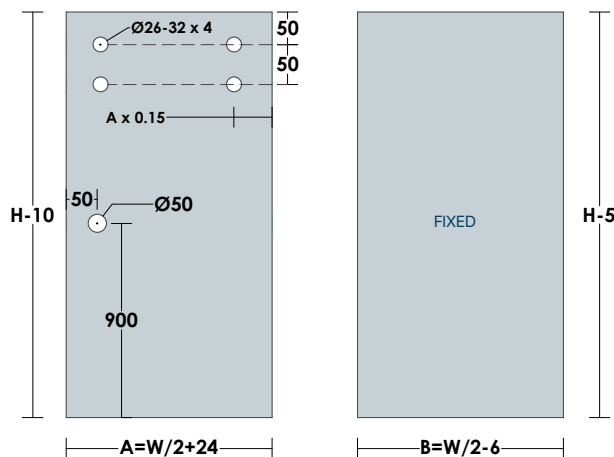

TOP VIEW DETAIL

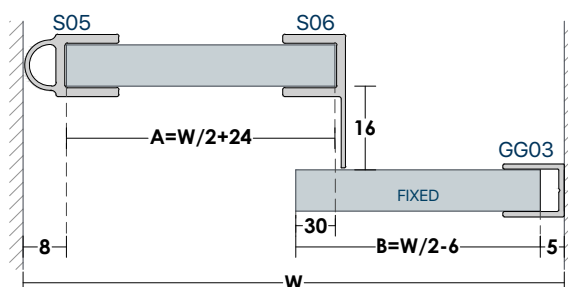



SA02 CABIN

•OPTIONAL **U** GG09 for **10mm** Glass Thickness



OPTIONAL KNOBS ▶ 74 - 75

SHOWER CABIN

GLASS PREPARATION

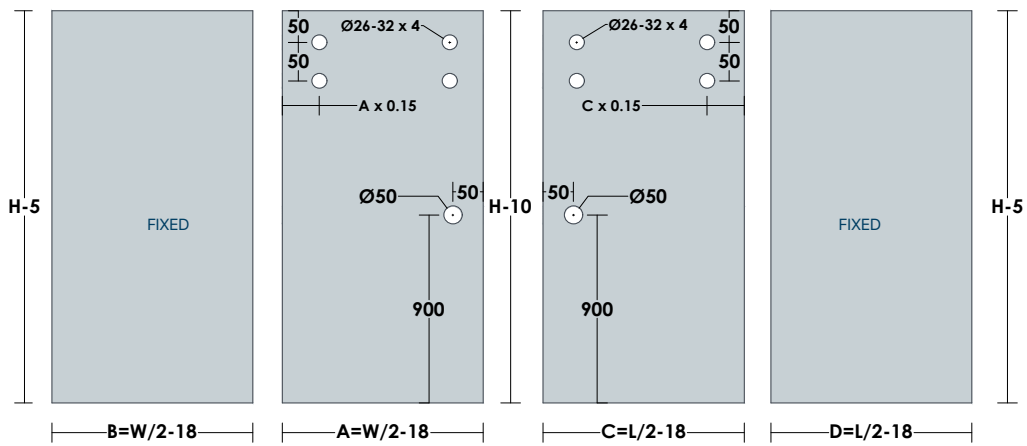

TOP VIEW DETAIL

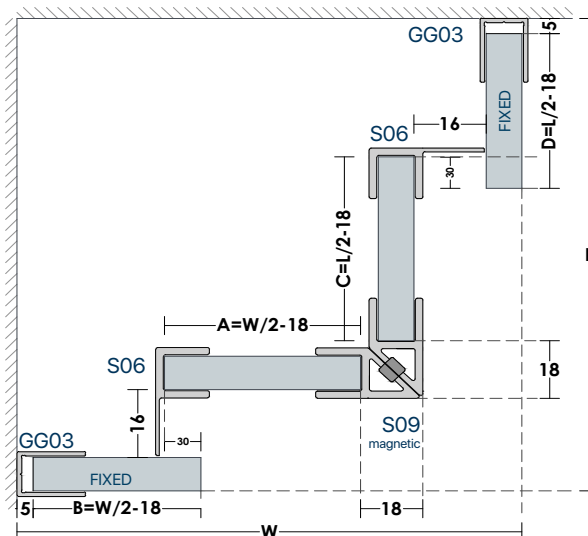



SHOWER CABIN SERIES | **A0**

SHOWER CABIN





A03 CABIN



•OPTIONAL **U** GG15,GG14, GG19 for **8mm** Glass Thickness

OPTIONAL KNOBS ▶ 73, 76-79

OPTIONAL HINGES ▶ 60-66

GLASS PREPARATION

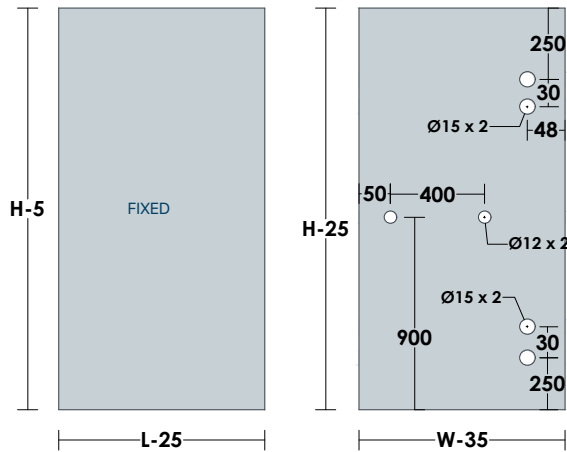

TOP VIEW DETAIL

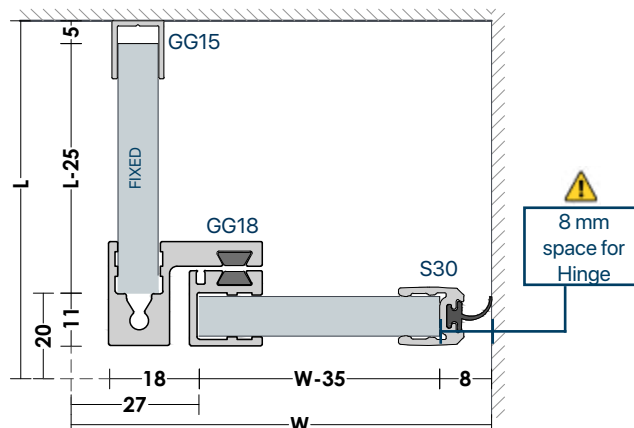



A04 CABIN

•OPTIONAL **U** GG15,GG14, GG19 for **8mm** Glass Thickness



OPTIONAL KNOBS ▶ 73, 76-79

OPTIONAL HINGES ▶ 60-66

SHOWER CABIN



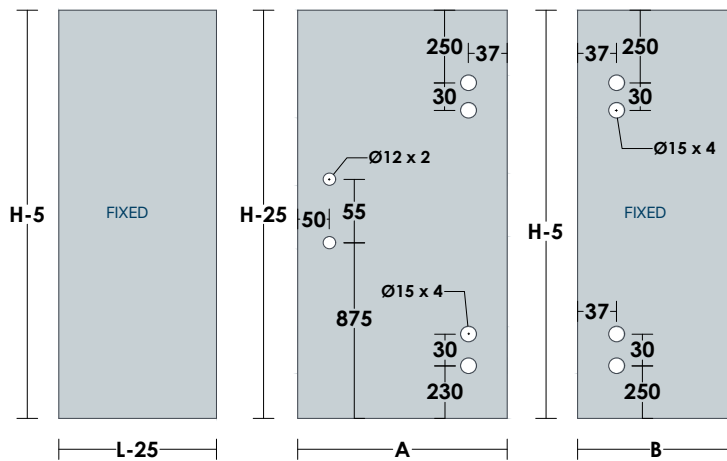

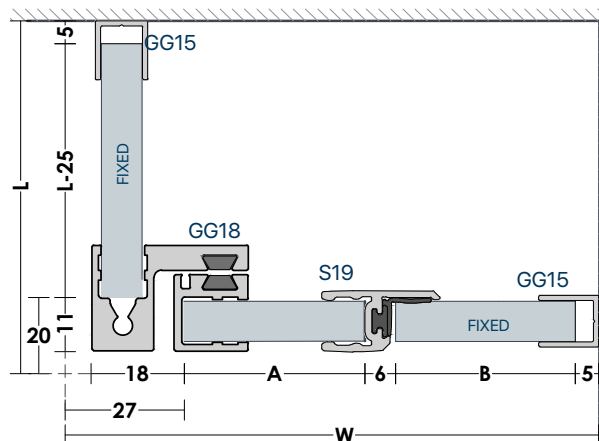

GLASS PREPARATION

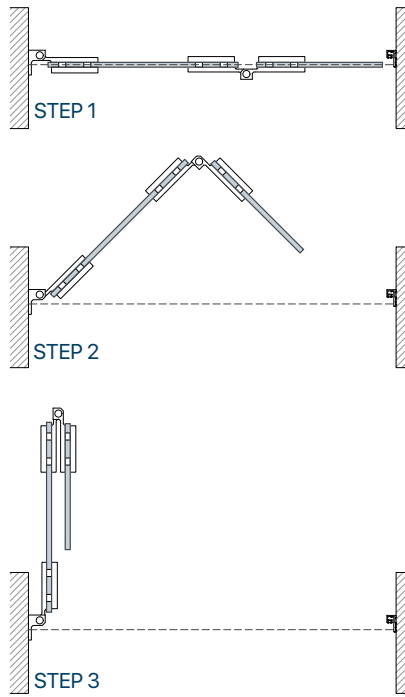

TOP VIEW DETAIL





- 1 x GG10 
- 2 x SH45 (Optional) 
- 2 x SH46 (Optional) 
- 2 x S30 
- 1 x S21 
- 1 x S19 
- 2 x DK06 (Optional) 

OPTIONAL KNOBS ► 74 - 75
 OPTIONAL HINGES ► 60-65

A06 CABIN

GLASS PREPARATION

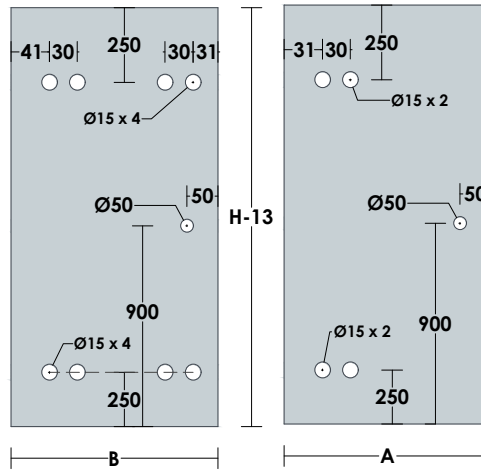

TOP VIEW DETAIL

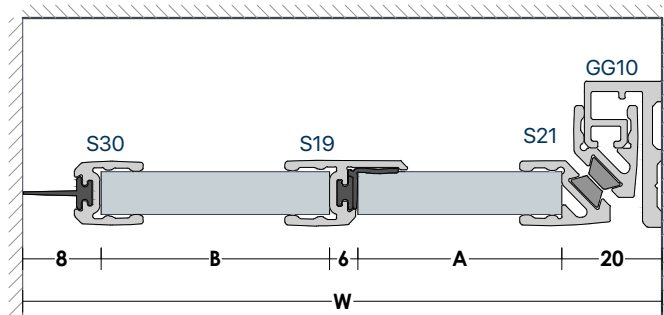

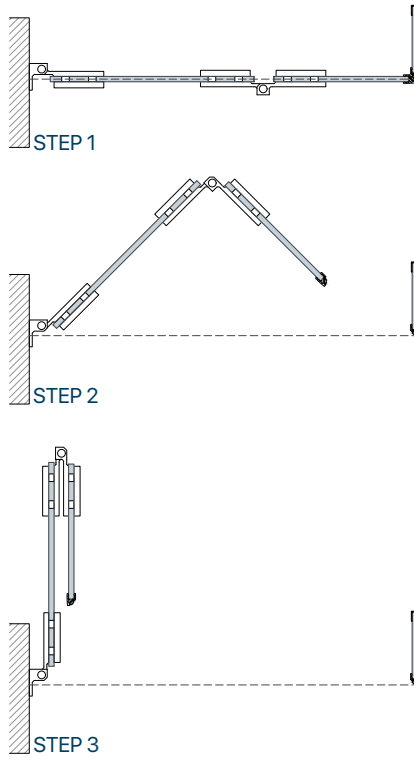

- 2 x SH47 (Optional)
- 2 x SH48 (Optional)
- 1 x HL38
- 1 x HL34
- 1 x GT02
- 2 x S30
- 1 x S21
- 1 x S19
- 1 x GG15
- 2 x DK06 (Optional)



A16 CABIN

OPTIONAL KNOBS ▶ 74 - 75
 OPTIONAL HINGES ▶ 60-65

GLASS PREPARATION

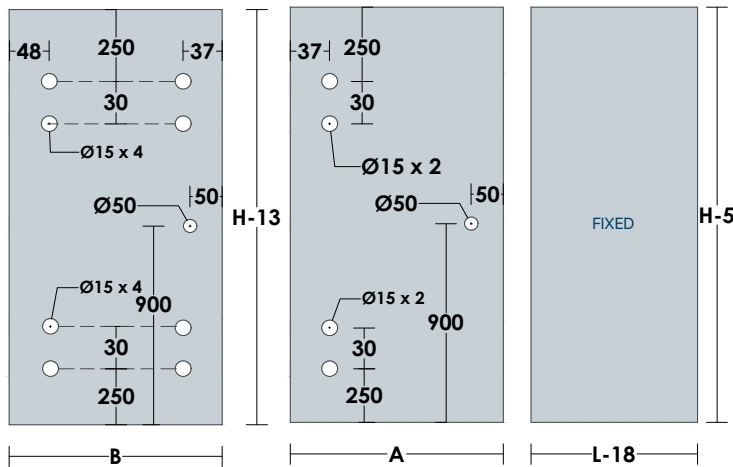

TOP VIEW DETAIL

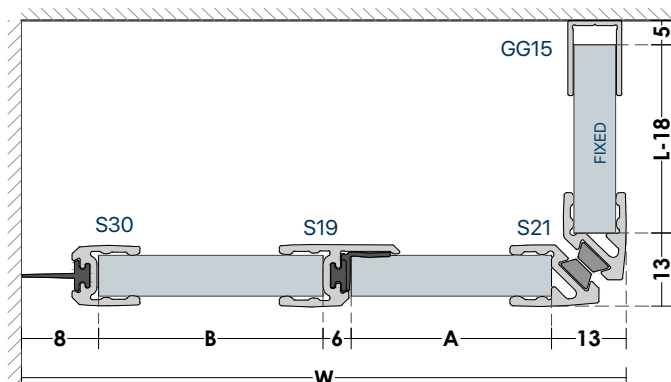



SHOWER CABIN SERIES | **BO**

SHOWER CABIN

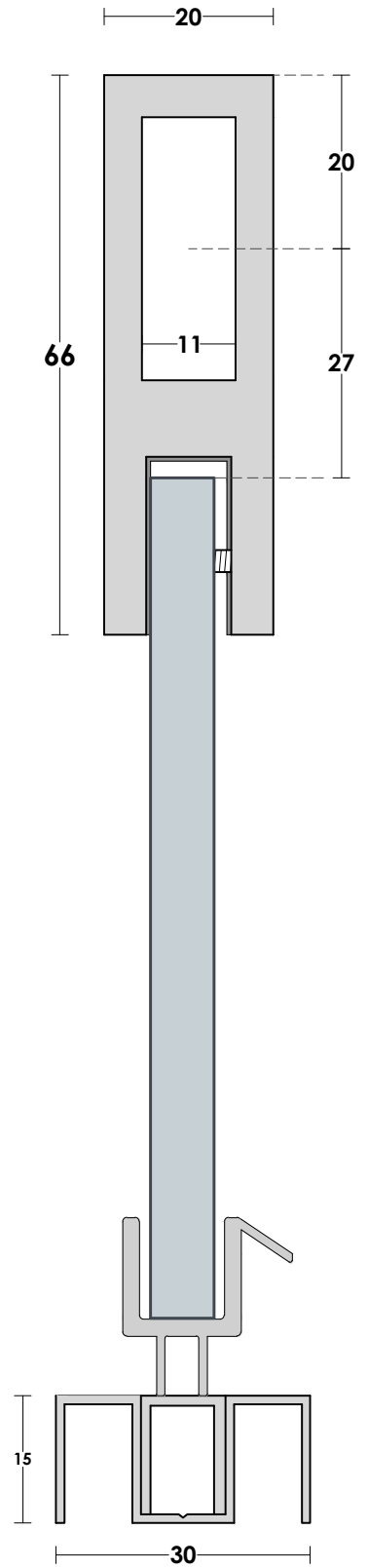
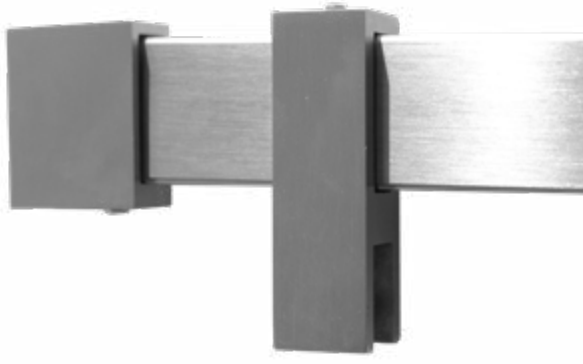



B01 CABIN



•OPTIONAL **U** GG15,GG14, GG19 for **8mm** Glass Thickness | Alu - PVC
 GG03 for **10mm** Glass Thickness | PVC

OPTIONAL KNOBS ▶ 73, 76-79
 OPTIONAL HINGES ▶ 60-66

GLASS PREPARATION

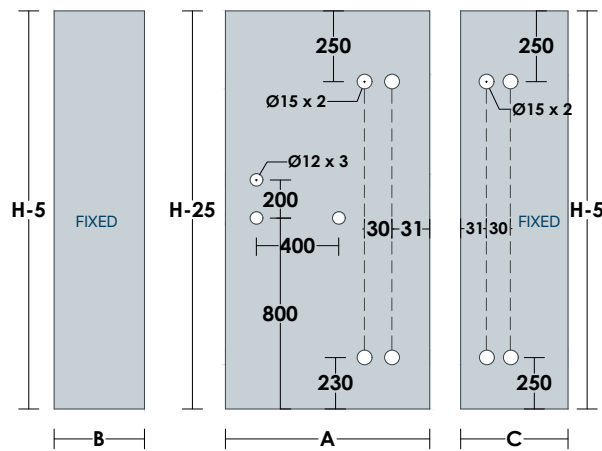

TOP VIEW DETAIL

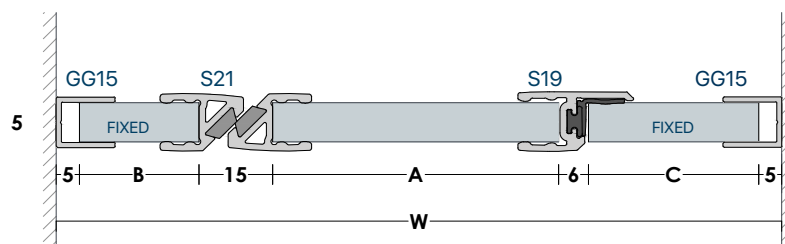



B02 CABIN

•OPTIONAL **U** GG15,GG14, GG19 for **8mm** Glass Thickness
GG03 for **10mm** Glass Thickness

Alu - PVC
PVC

OPTIONAL KNOBS ▶ 73, 76-79
OPTIONAL HINGES ▶ 60-66

GLASS PREPARATION

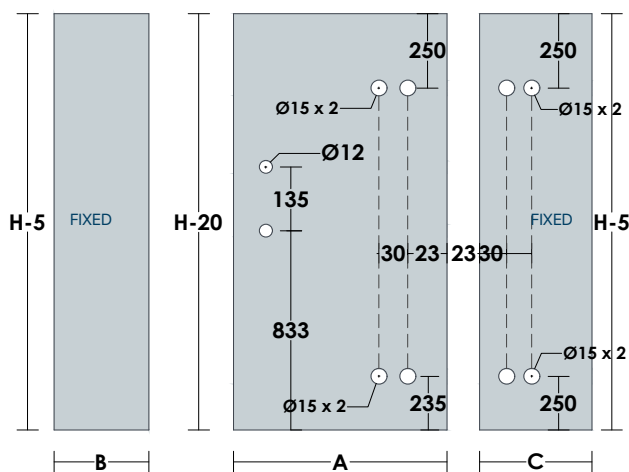

TOP VIEW DETAIL

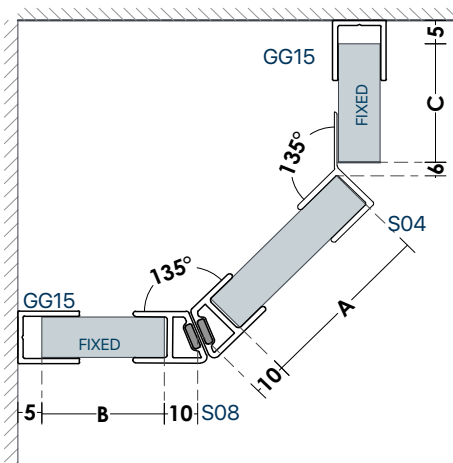

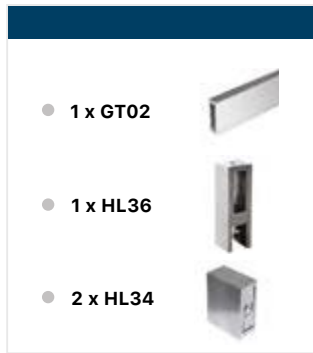

B05 CABIN

•OPTIONAL **U** GG15,GG14, GG19 for **8mm** Glass Thickness
GG03 for **10mm** Glass Thickness

OPTIONAL KNOBS ▶ 73, 76-79
OPTIONAL HINGES ▶ 60-66

GLASS PREPARATION

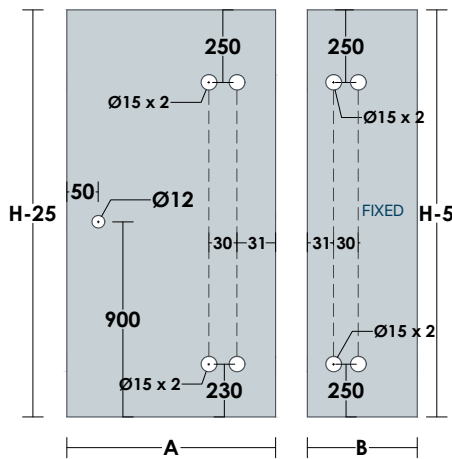

TOP VIEW DETAIL

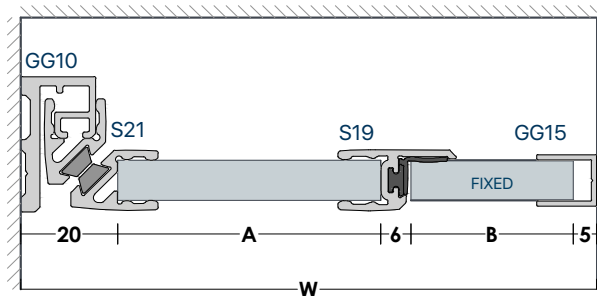



SHOWER CABIN

B09 CABIN

• OPTIONAL **U** GG15, GG14, GG19 for **8mm** Glass Thickness
GG03 for **10mm** Glass Thickness

OPTIONAL KNOBS ▶ 73, 76-79
OPTIONAL HINGES ▶ 60-66

GLASS PREPARATION

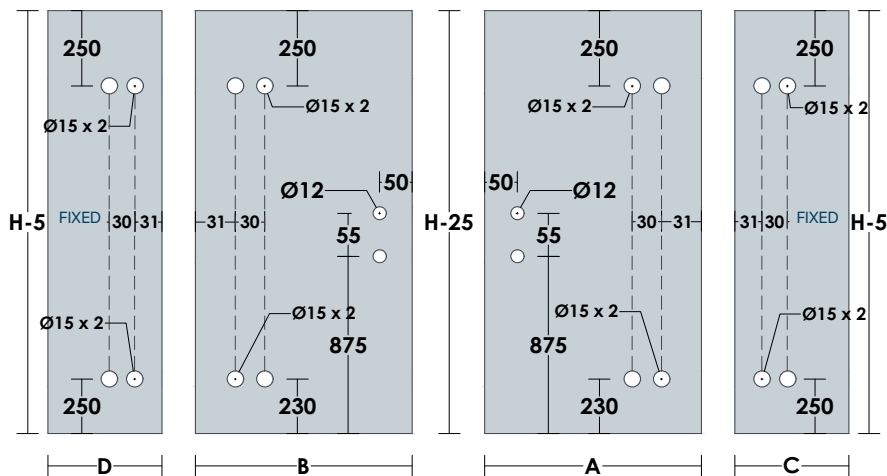

TOP VIEW DETAIL

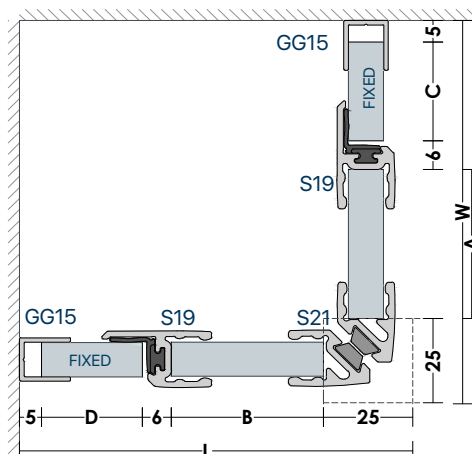

WN | WALK-IN CABIN SERIES



Glass Thickness: 8-10mm

WN01 Cabin

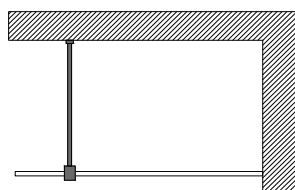

WN02 Cabin

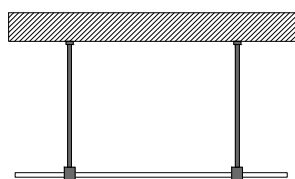

WN03 Cabin

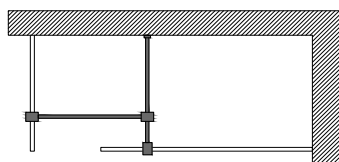

WN04 Cabin

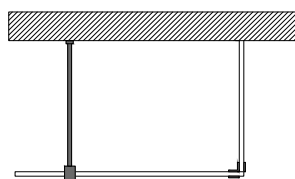



WC CUBICLE SERIES

ST9





WC CUBICLE SERIES

SA9



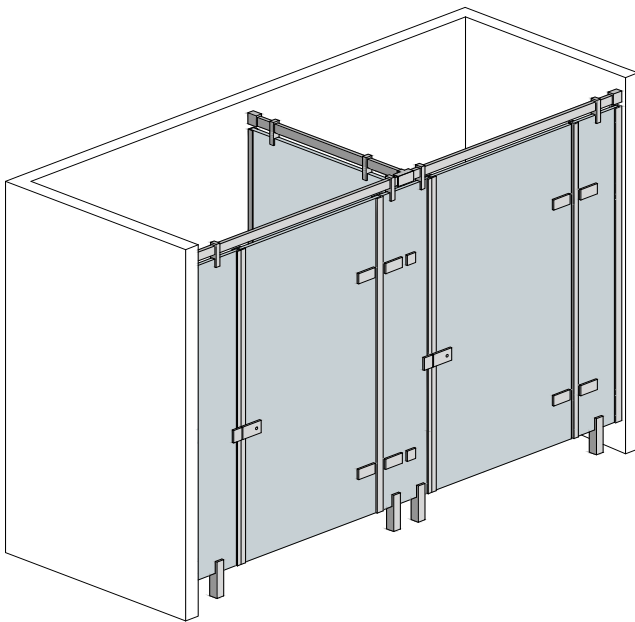

● 1 x GT01



6 x HL43



● 6 x HL36



4 x SH46



● 3 x HL34



2 x BL16



● 1 x HL40



3 x GG15



2 x GC35



2 x S21



2 x S19



ST9 PARTITIONS

GLASS PREPARATION

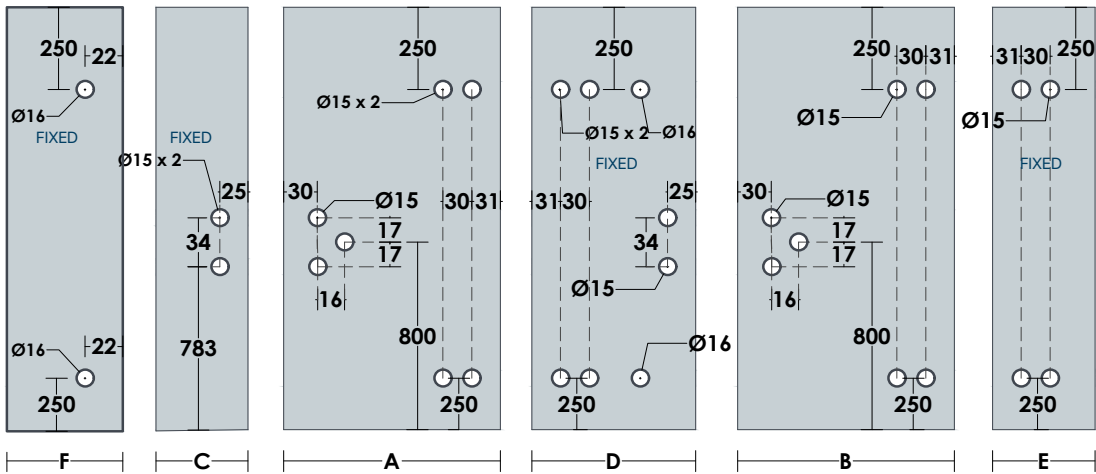

Installation with SH46 Hinge

TOP VIEW DETAIL

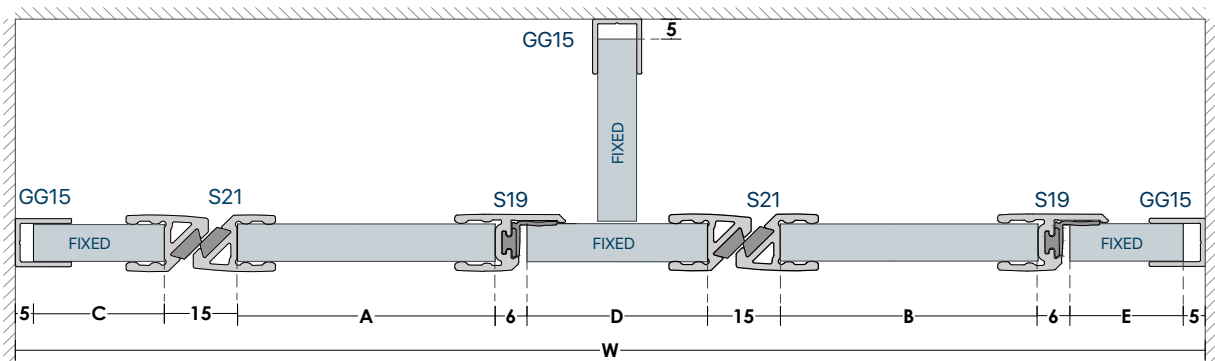

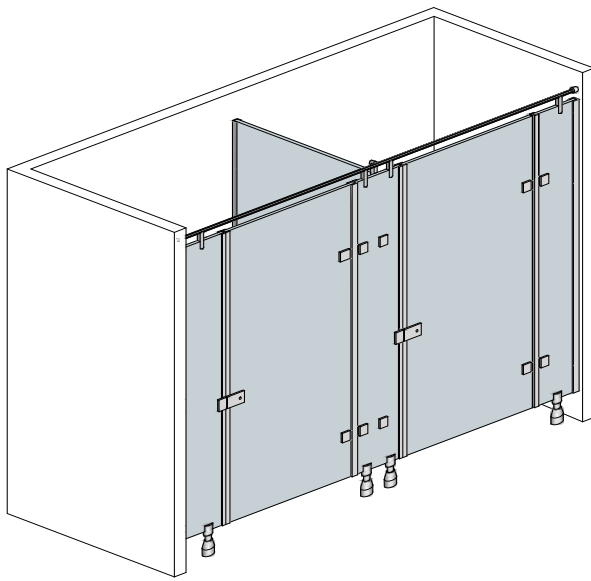

1 x GT01



6 x HL28



4 x HL05



4 x SH48



1 x HL04



2 x BL16



2 x HL07



3 x GG15



2 x GC05



2 x S21



2 x S19



SHOWER CABIN

SA9 PARTITIONS

GLASS PREPARATION

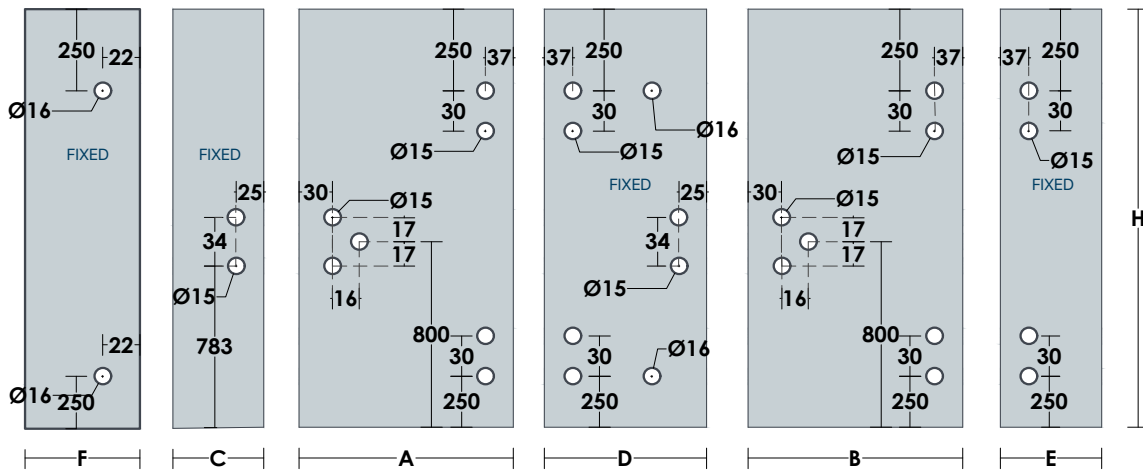

Installation with SH48 Hinge

TOP VIEW DETAIL

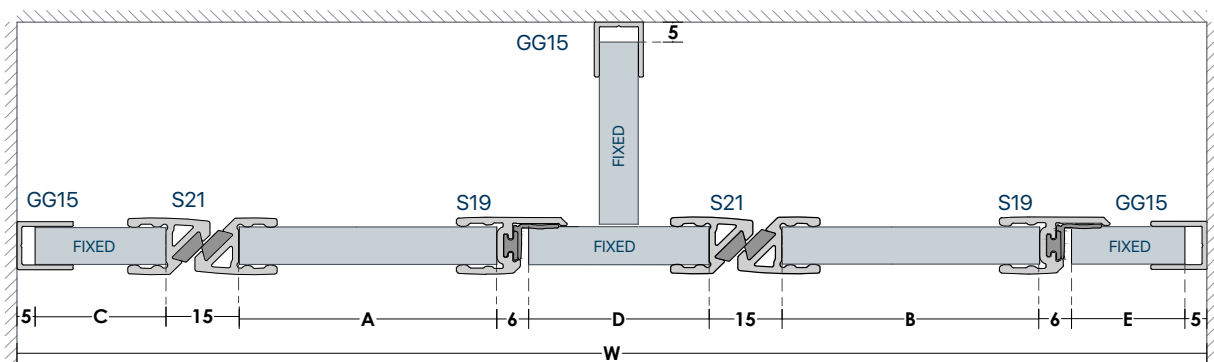

NEW BOTTOM GUIDE OPTIONS
for **SN** & **SX** sliding shower cabins

U - profile option

Waterproof bottom track option

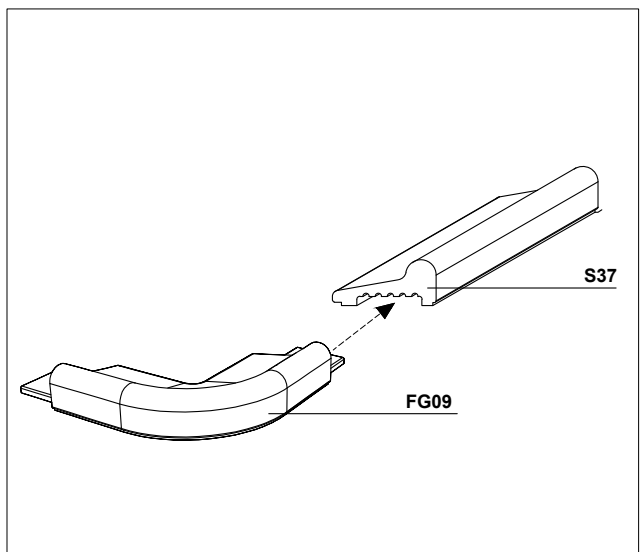
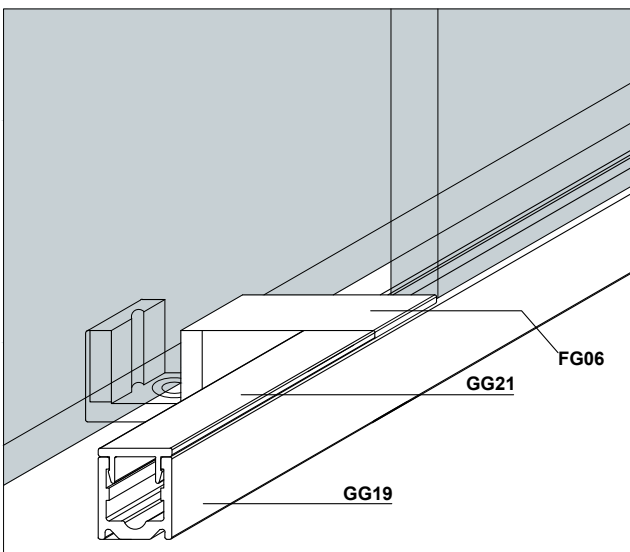
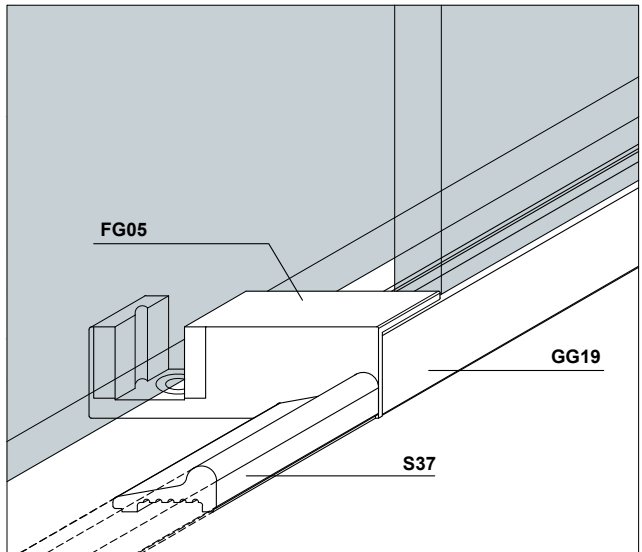
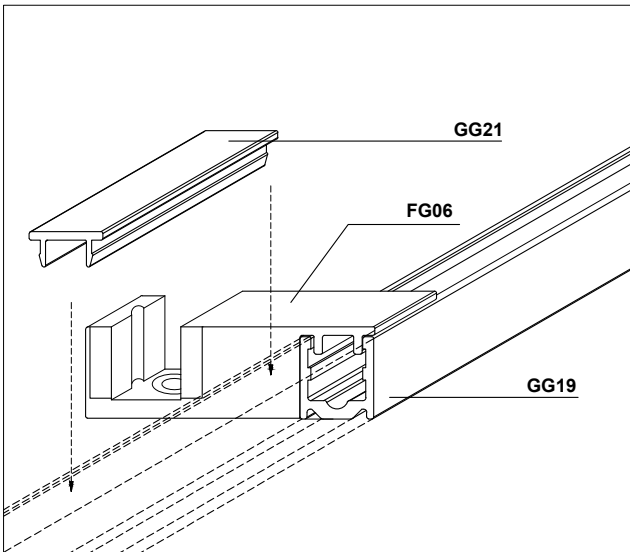
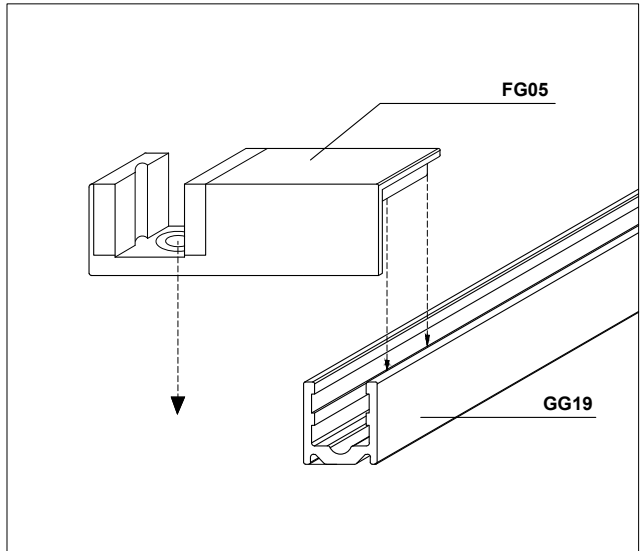
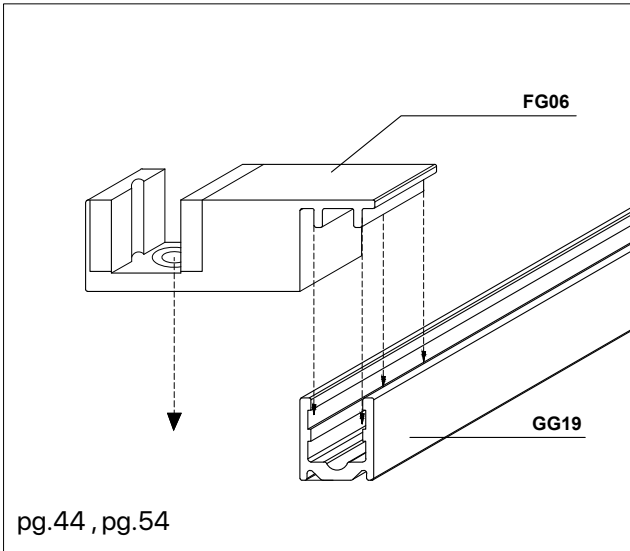

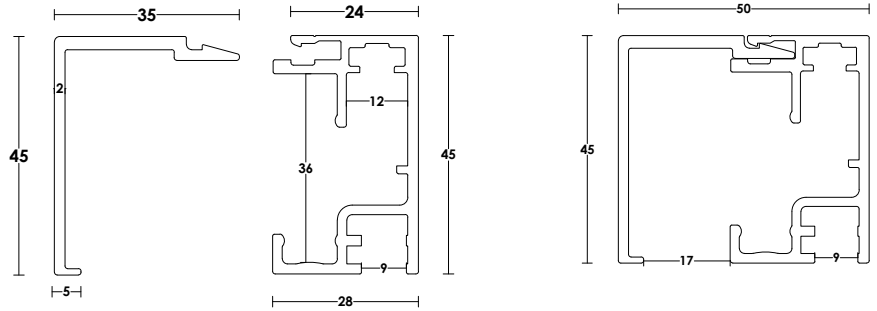

PCA-GT07
Guide Track Profile
 350cm | Length
 Aluminium | Material
 Satin, Black Anodize | Finish



PCA-HL48R
Fixing wall cap
 Stainless Steel 304 | Material
 Satin, Black Anodize | Finish

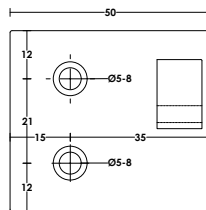

PCA-HL48L
Fixing wall cap
 Stainless Steel 304 | Material
 Satin, Black Anodize | Finish

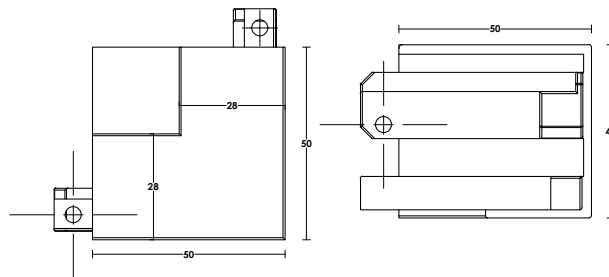
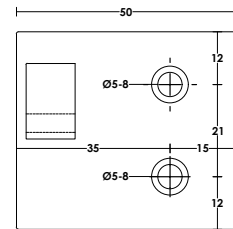

PCA-HL50
Guide connector
 Stainless Steel 304 | Material
 Satin, Black Anodize | Finish

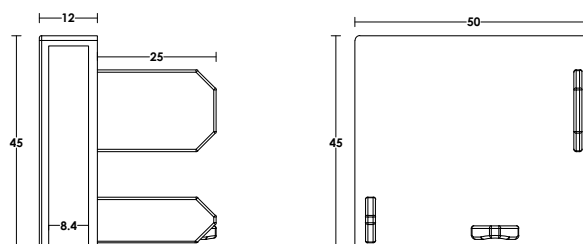

PCA-HL49R
Fix glass support
 Stainless Steel 304 | Material
 Satin, Black Anodize | Finish





PCA-HL49L

Fix glass support

Stainless Steel 304 | Material
Satin, Black Anodize | Finish

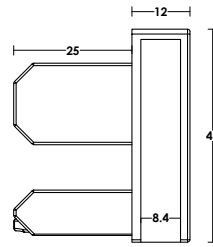
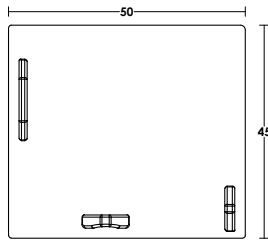

PCA-FG05R

Sliding glass guide

Stainless Steel 304 | Material
Satin, Black Anodize | Finish

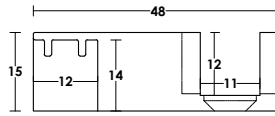
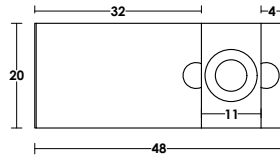

PCA-FG05L

Sliding glass guide

Stainless Steel 304 | Material
Satin, Black Anodize | Finish

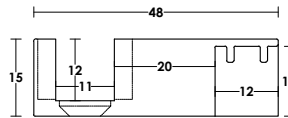
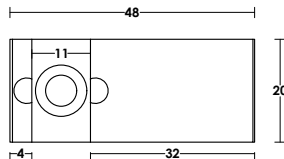

PCA-FG06

Sliding glass guide

Stainless Steel 304 | Material
Satin, Black Anodize | Finish

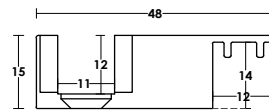
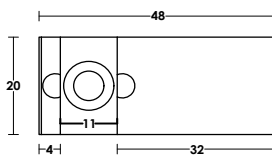

PCA-FG07

Sliding glass guide

Stainless Steel 304 | Material
Satin, Black Anodize | Finish

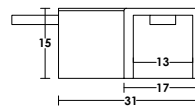
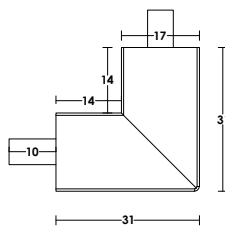

PCA-FG10

Sliding glass guide

Stainless Steel 304 | Material
Satin, Black Anodize | Finish

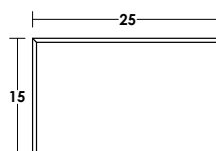
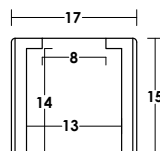

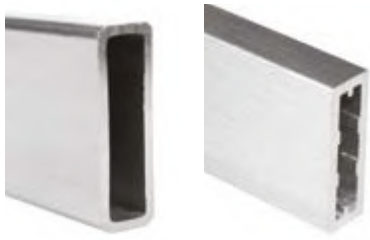

600cm 220cm

PCA-GT02
Guide Track Profile
 220, 600cm | Length
 Aluminium, Stainless Steel 304 | Material
 Satin, Polished, Black Anodize | Finish



stainless steel aluminium

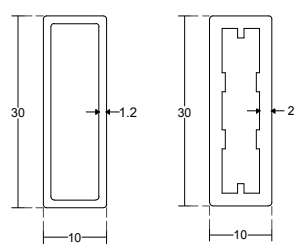

SN KIT - 2 PCS EACH PRODUCT



PCA-RH18
Flat Track Roller Hanger
 8-10mm | Glass Thickness
 Stainless Steel 304 | Material
 Satin, Polished, Black Anodize | Finish

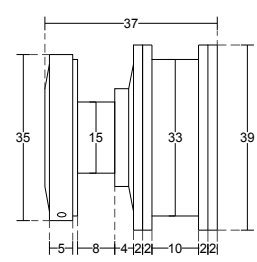
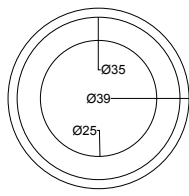

PCA-RH18B
Flat Track Roller Hanger Support
 8 - 10mm | Glass Thickness
 Stainless Steel 304 | Material
 Satin, Polished | Finish

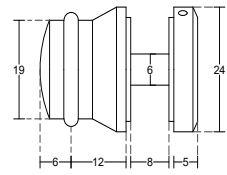
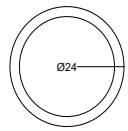

PCA-HL39
Flat Track - Glass Holder
 8 - 10mm | Glass Thickness
 Stainless Steel 304 | Material
 Satin, Polished, Black Anodize | Finish

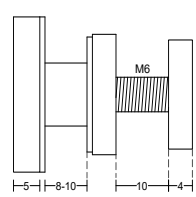
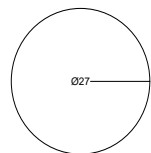

PCA-SP14
Flat Track Stop
 Stainless Steel 304 | Material
 Satin, Polished | Finish

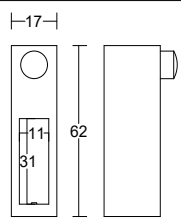

PCA-HL34
Flat Track - Wall Holder
 Stainless Steel 304 | Material
 Satin, Polished, Black Anodize | Finish

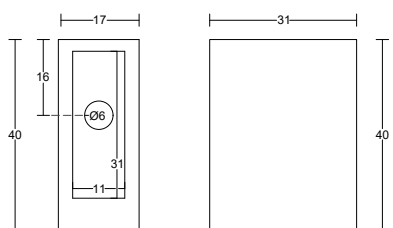

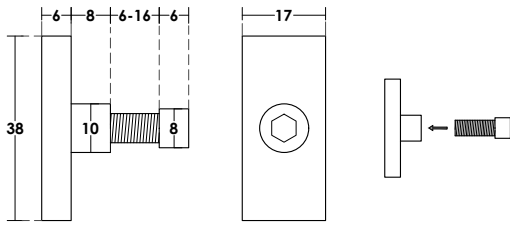

PCA-HL34
Flat Track - Glass Holder Screw
 Stainless Steel 304 | Material
 Satin, Polished, Black Anodize | Finish



CORNER TRACK HOLDERS

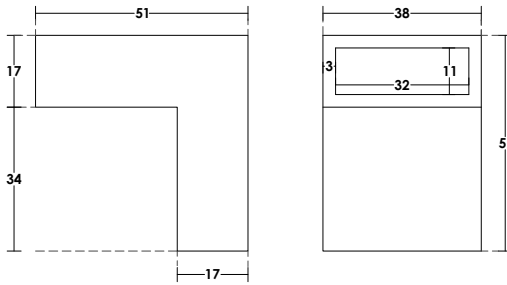

PCA-HL35
90° Flat Track - Track Holder
 45 kg | Max. Weight
 Stainless Steel 304 | Material
 Satin, Polished, Black Anodize | Finish

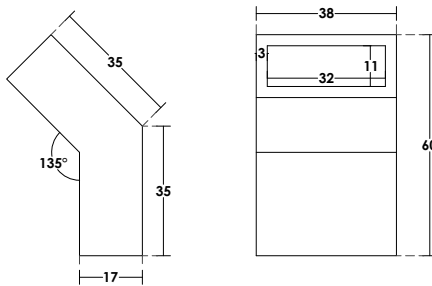

PCA-HL08
135° Flat Track - Track Holder
 45 kg | Max. Weight
 Stainless Steel 304 | Material
 Satin, Polished | Finish

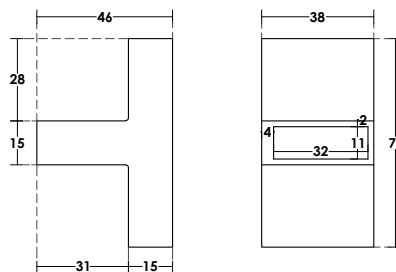

PCA-HL40
Flat Track - Glass Holder
 45 kg | Max. Weight
 Stainless Steel 304 | Material
 Satin, Polished | Finish



Cabin Floor accessories



PCA-FG01A | FG01B | FG01C

Floor Guide

8,10,12mm | Glass Thickness
Stainless Steel 304 | Material
Satin, Polished, Black Anodize | Finish

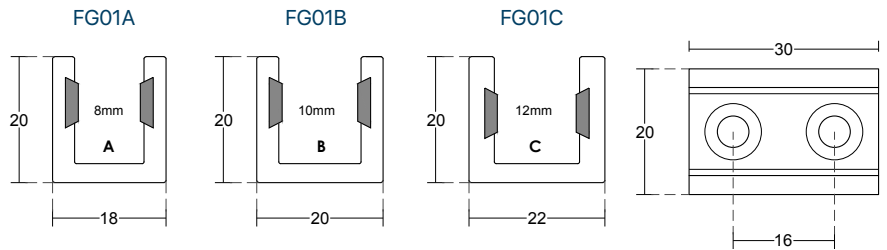

PCA-FG04

Floor Guide

Stainless Steel 304 | Material
Satin, Polished | Finish

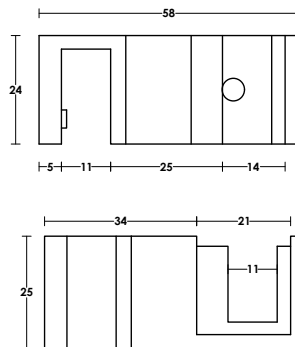

PCA-FG09

Waterproof profile corner

Stainless Steel 304 | Material
Satin, Black Anodize | Finish

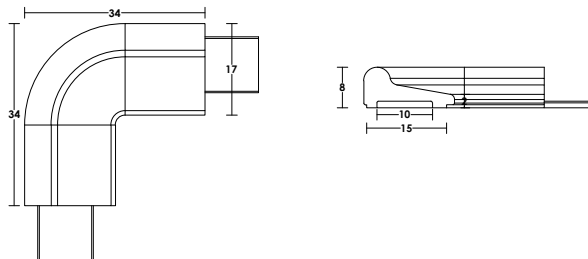

PCA-FG02

Corner Floor Guide

Stainless Steel 304 | Material
Satin, Polished, Black Anodize | Finish



Installation with FG02 Corner

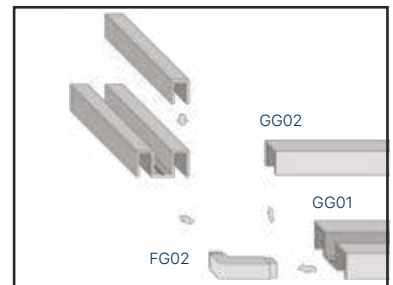

PCA-FG03

Corner Floor Guide

Stainless Steel 304 | Material
Satin, Polished | Finish

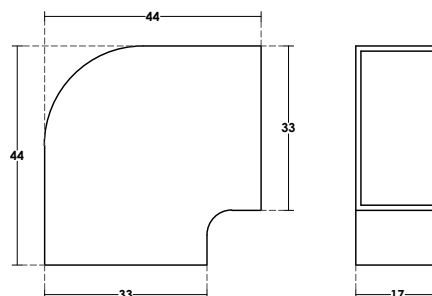

Installation with FG03 Corner

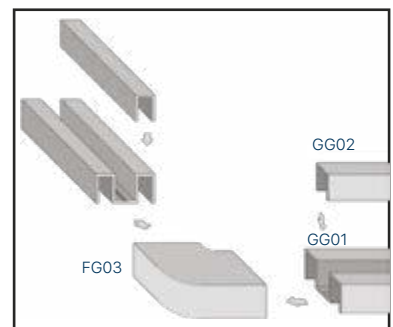

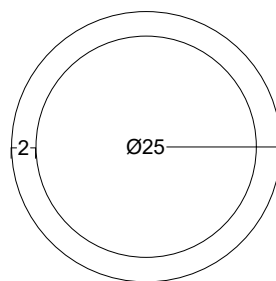

PCA-GT01
Guide Track Profile
 600cm | Length
 Stainless Steel 304 | Material
 Satin | Finish

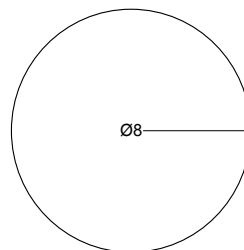

PCA-RD01
Round Rod
 150cm | Length
 Stainless Steel 304 | Material
 Satin | Finish

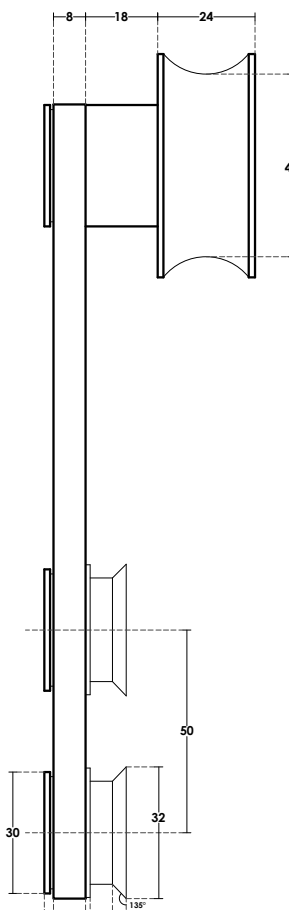
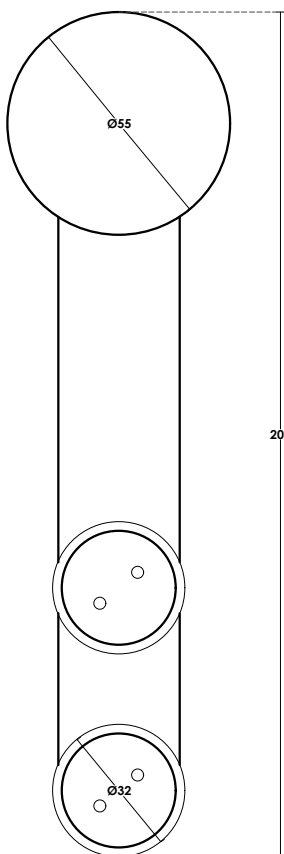

Up side of Glass
 COUNTER SUNK HOLES

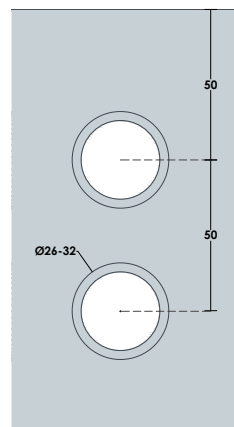

PCA-RH01
Round Track Roller Hanger
 10mm | Glass Thickness
 80 kg | Max. Weight
 Stainless Steel 304 | Material
 Satin | Finish



PCA-SP01
Round Track Stop
 Stainless Steel 304 | Material
 Satin | Finish

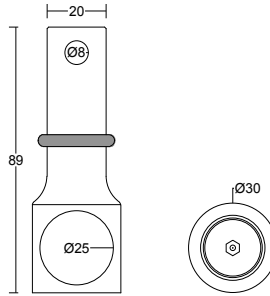

PCA-HL06
Round Track - Track Holder
 50 kg | Max. Weight
 Stainless Steel 304 | Material
 Satin | Finish

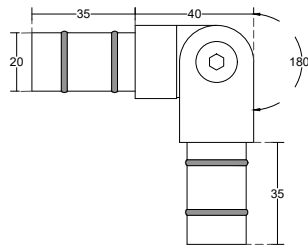

PCA-HL07
Flat Track - Wall Holder
 50 kg | Max. Weight
 Stainless Steel 304 | Material
 Satin | Finish

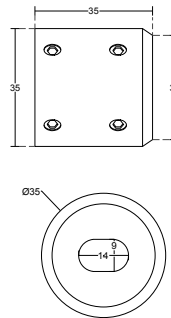

PCA-HL05
Round Track - Glass Holder
 10mm | Glass Thickness
 Stainless Steel 304 | Material
 Satin | Finish

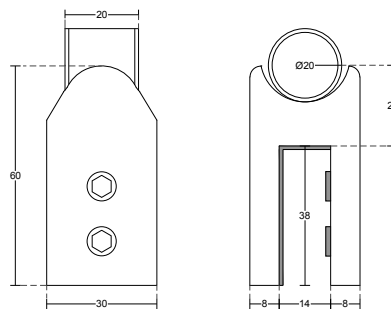

PCA-HL04
Round Track - Glass Holder
 10mm | Glass Thickness
 Stainless Steel 304 | Material
 Satin | Finish

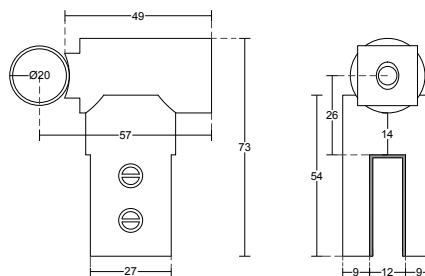

WC Partition Glass Holders

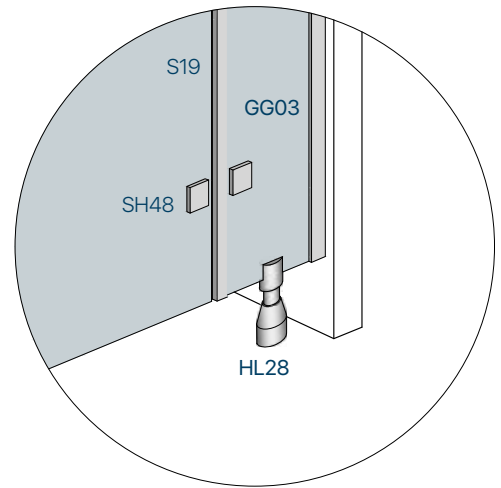
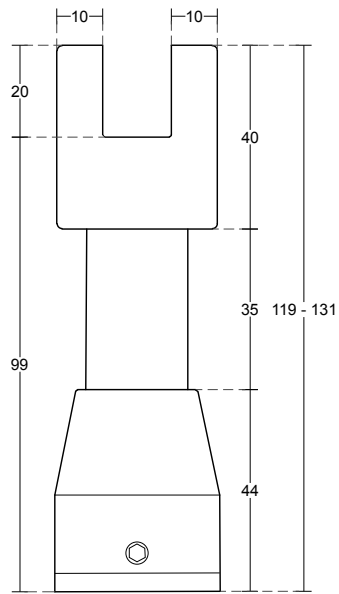

PCA-HL28

Floor Glass Holder

10mm | Glass Thickness
80 kg | Max. Weight
Stainless Steel 304 | Material
Satin, Polished | Finish

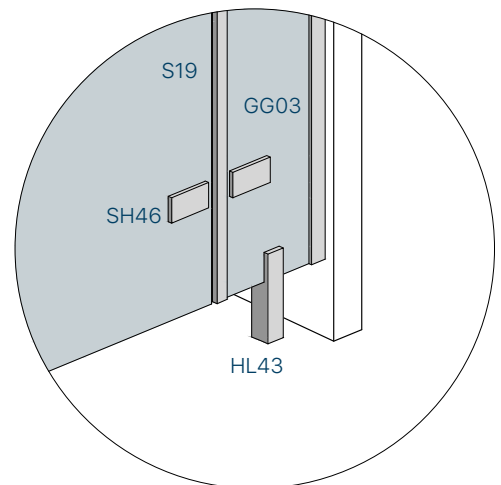
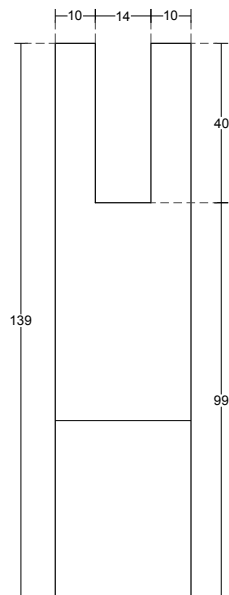
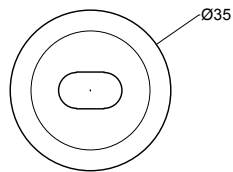

PCA-HL43

Floor Glass Holder

10mm | Glass Thickness
80 kg | Max. Weight
Stainless Steel 304 | Material
Satin, Polished | Finish

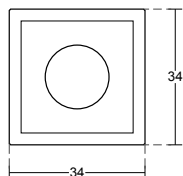

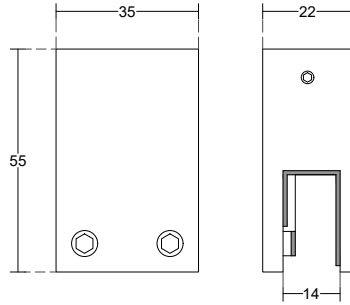
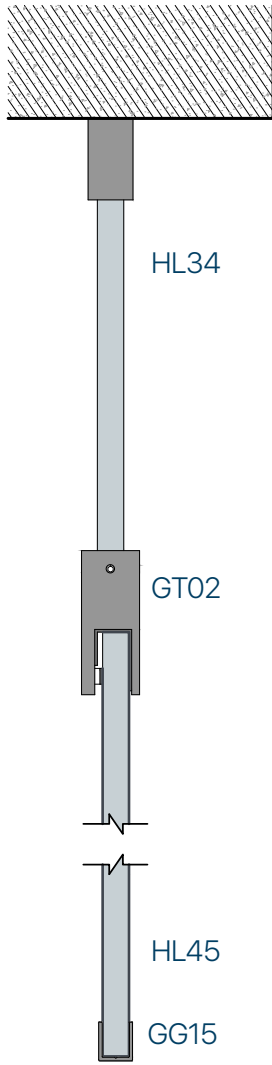

PCA-HL45
Glass - Track Holder
8,10mm | Glass Thickness
Stainless Steel 304 | Material
Satin, Polished | Finish

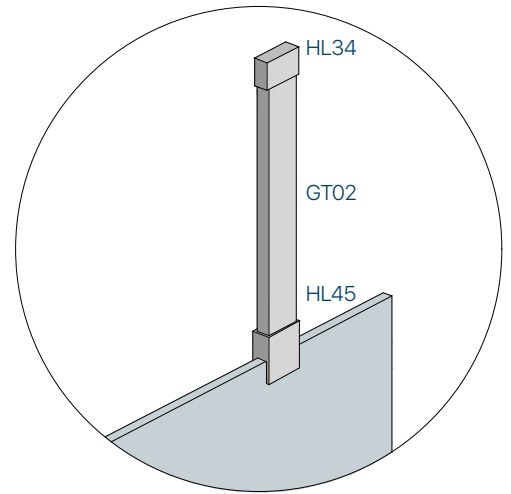
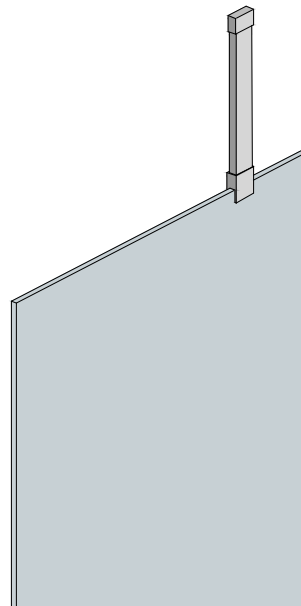

•OPTIONAL U PROFILES ▶ 52

FIX GLASS INSTALLATION

NEW

WN03 Cabin

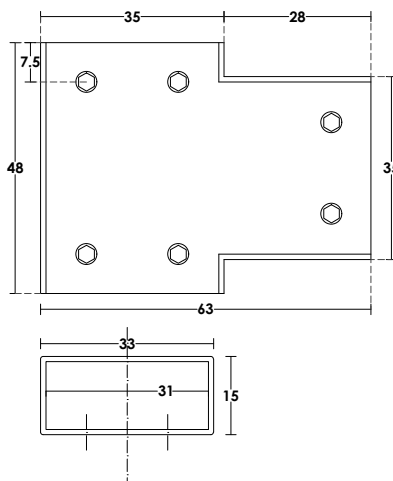
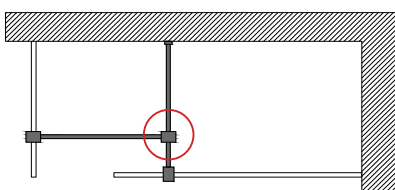

PCA-HL51
Track Holder
Stainless Steel 304 | Material
Satin, Polished, Black Anodize | Finish



PCA-HL44
Adjustable Wall - Track Holder
 Stainless Steel 304 | Material
 Satin, Polished, Black Anodize | Finish

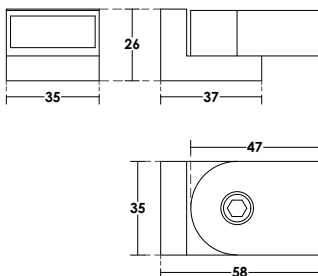

PCA-HL47
Adjustable Glass - Track Holder
 10mm | Glass Thickness
 Stainless Steel 304 | Material
 Satin, Polished, Black Anodize | Finish

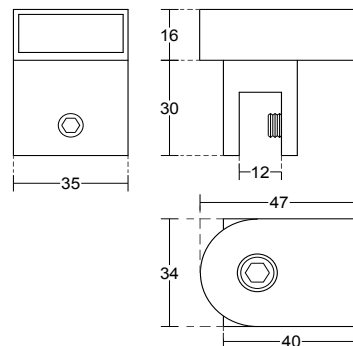

GT02 + HL44 + HL47



PCA-HL37
Glass - Track Holder
 8,10mm | Glass Thickness
 Stainless Steel 304 | Material
 Satin, Polished, Black Anodize | Finish

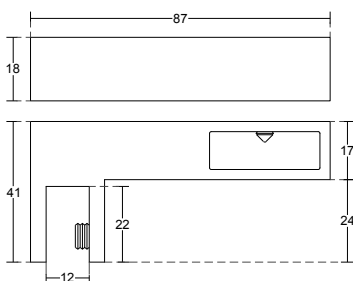

PCA-HL38
Glass - Track Holder
 8,10mm | Glass Thickness
 Stainless Steel 304 | Material
 Satin, Polished, Black Anodize | Finish

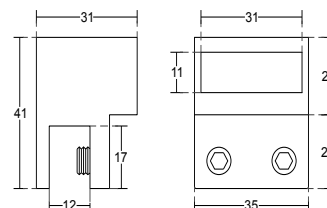

GT02 + HL37 + HL38 + HL34



PCA-HL36
Glass - Track Holder
 8,10mm | Glass Thickness
 Stainless Steel 304 | Material
 Satin, Polished, Black Anodize | Finish

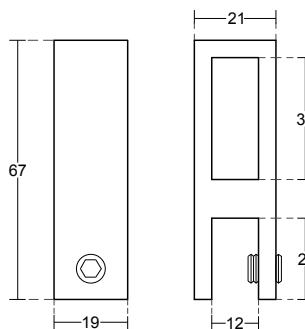

GT02 + HL36 + HL34 + HL35

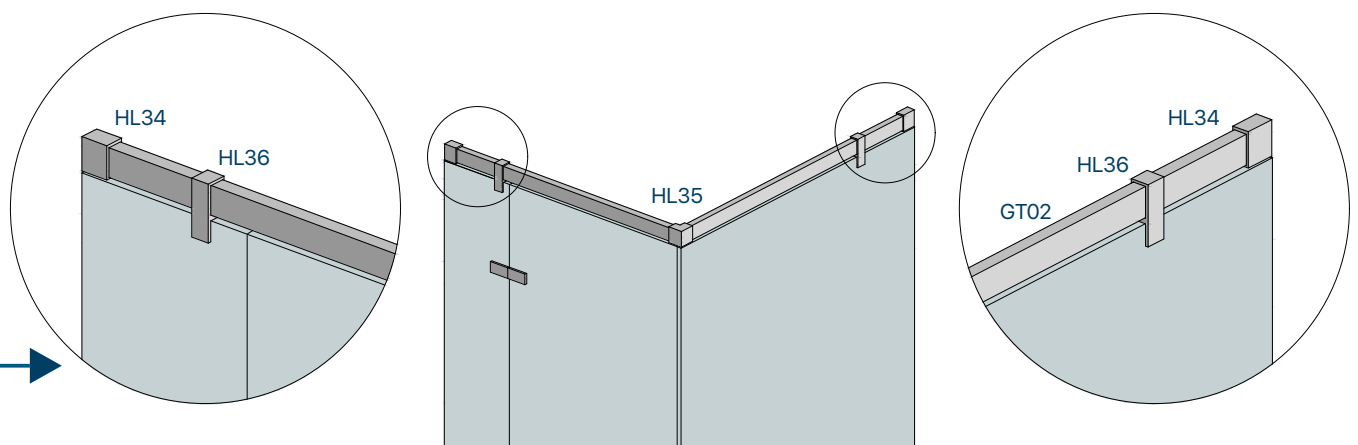
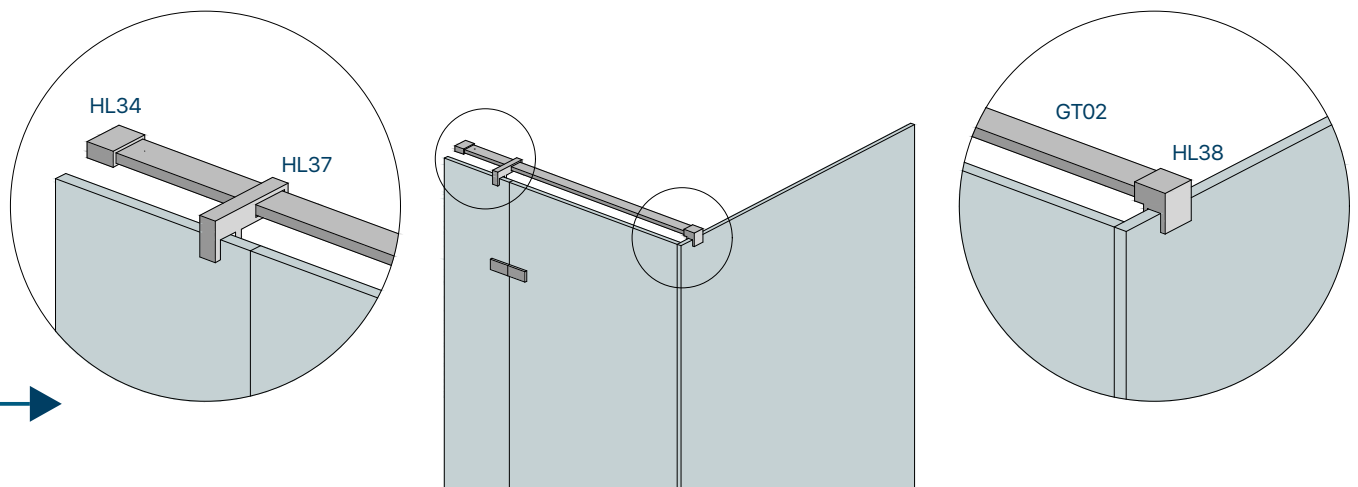
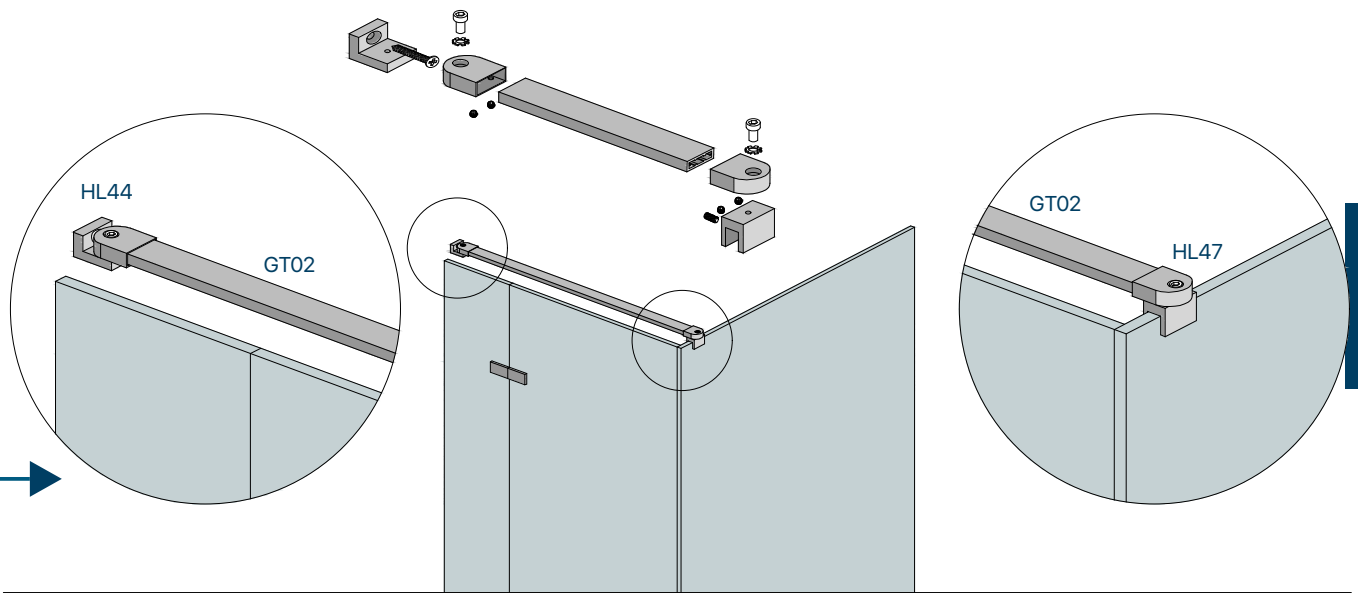



PCA-GG01
U Channel Profile
 220,300 cm | Length
 8,10mm | Glass Thickness
 Aluminium | Material
 Satin, Polished, Black Anodize | Finish

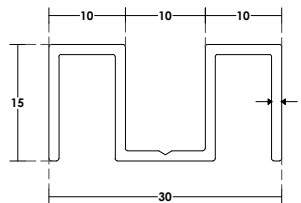

PCA-GG02
U Channel Profile
 220 cm | Length
 6 mm | Glass Thickness
 Aluminium | Material
 Satin, Polished, Black Anodize | Finish

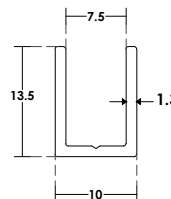

PCA-GG03
U Channel Profile
 220, 300 cm | Length
 10mm | Glass Thickness
 Aluminium | Material
 Satin, Polished, Black Anodize | Finish

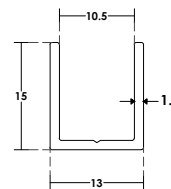

PCA-GG15
U Channel Profile
 220, 300 cm | Length
 8 mm | Glass Thickness
 Aluminium | Material
 Satin, Polished, Black Anodize | Finish

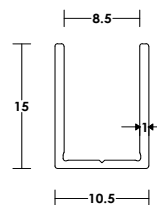

PCA-GG14
U Channel Profile
 220, 300 cm | Length
 8 mm | Glass Thickness
 Aluminium | Material
 Satin, Polished, Black Anodize | Finish

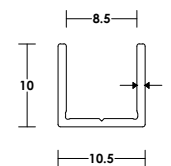

PCA-GG19
U Channel Profile
 220, 300 cm | Length
 8 mm | Glass Thickness
 Aluminium | Material
 Satin, Polished, Black Anodize | Finish

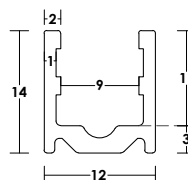

PCA-GG21
Cover for U Profile
 220, 300 cm | Length
 8 mm | Glass Thickness
 Aluminium | Material
 Satin, Polished, Black Anodize | Finish

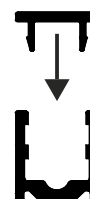
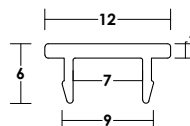

GG19



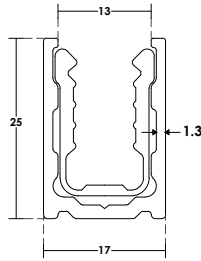

PCA-GG09
U Channel Profile
 220,300 cm | Length
 8, 10mm | Glass Thickness
 Aluminium | Material
 Satin, Polished, Black Anodize, Natural Anodize | Finish

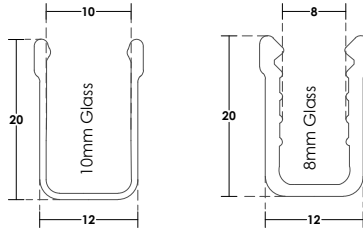

PCA-GG09-8 | GG09-10
U Channel Profile Rubber
 88 m Roll | Unit
 8,10mm | Glass Thickness
 PVC | Material
 Grey | Finish

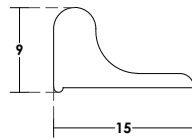

PCA-S29
Waterproof Bottom Track
 300 cm | Length
 Aluminium | Material
 Polished, Black Anodize | Finish



COMPATIBLE WITH FG09



NEW

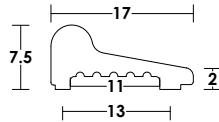

PCA-S37
Waterproof Bottom Track
 220 cm | Length
 Aluminium | Material
 Satin, Polished, Black Anodize | Finish

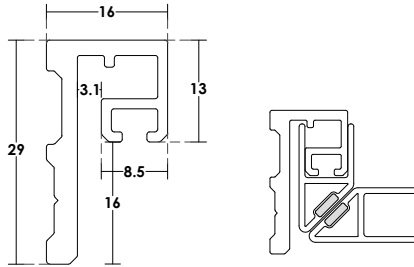

PCA-GG10
Waterproof Seal Fixing Profile
 220, 300 cm | Length
 8 mm | Seal Thickness
 Aluminium | Material
 Satin, Polished, Black Anodize | Finish

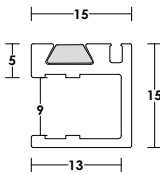

GG18-2

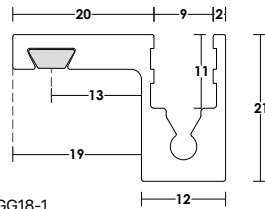

GG18-1



PCA-GG18
Magnet Fixing Profile
 220, 300 cm | Length
 8 mm | Glass Thickness
 Aluminium | Material
 Satin, Polished, Black Anodize | Finish

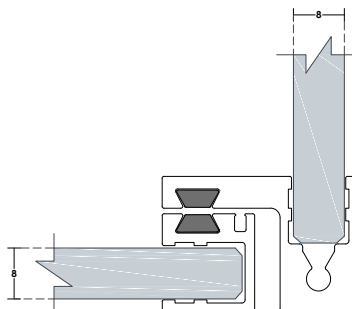

NEW



PCA-S19
Waterproof Sealant
 8mm | Glass Thickness
 220, 300 cm | Length
 Aluminium | Material
 Satin, Polished, Black Anodize | Finish

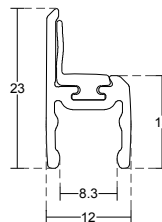

PCA-S30
Waterproof Sealant
 8, mm | Glass Thickness
 220, 300 cm | Length
 Aluminium | Material
 Satin, Polished, Black Anodize | Finish

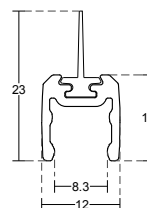

PCA-S36
Waterproof Sealant
 8 mm | Glass Thickness
 220, 300 cm | Length
 Aluminium | Material
 Satin, Polished, Black Anodize | Finish

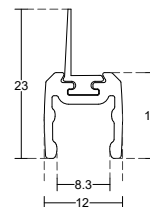

PCA-S25
Waterproof Sealant
 8 mm | Glass Thickness
 220, 300 cm | Length
 Aluminium | Material
 Satin, Polished, Black Anodize | Finish

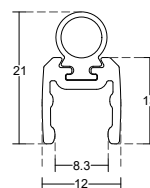

PCA-S26
Waterproof Sealant
 8 mm | Glass Thickness
 220, 300 cm | Length
 Aluminium | Material
 Satin, Polished, Black Anodize | Finish

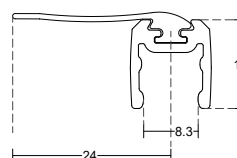

PCA-S21
Waterproof Sealant
 8 mm | Glass Thickness
 220, 300 cm | Length
 Aluminium | Material
 Satin, Polished, Black Anodize | Finish

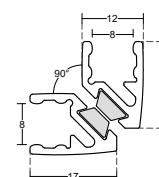

PCA-S01
Waterproof Sealant
6,8,10,12mm | Glass Thickness
220cm | Length
PVC | Material

12
14
26
14

PCA-S02
Waterproof Sealant
8,10mm | Glass Thickness
220cm | Length
PVC | Material

14
14
26
12

PCA-S04
Waterproof Sealant
6,8,10mm | Glass Thickness
220cm | Length
PVC | Material

135°
14
14

PCA-S05
Waterproof Sealant
6,8,10mm | Glass Thickness
300,220cm | Length
PVC | Material

21
14
7

PCA-S06
Waterproof Sealant
6,8,10mm | Glass Thickness
300,220cm | Length
16,25,30mm | Wing Length
PVC | Material

30
14
14
16

PCA-S07
Waterproof Sealant
6,8,10mm | Glass Thickness
220cm | Length
PVC | Material

14
21
7
14
6

PCA-S08
Waterproof Sealant 135° Magnet
8,10mm | Glass Thickness
220cm | Length
PVC | Material

135°
14
24
24
14

PCA-S09
Waterproof Sealant 90° Magnet
8,10mm | Glass Thickness
300,220cm | Length
PVC | Material

90°
30
16
14

PCA-S10
Waterproof Sealant 180° Magnet
8,10mm | Glass Thickness
220cm | Length
PVC | Material

20
14
20
20

PCA-S11
Waterproof Sealant
8,10mm | Glass Thickness
300,220cm | Length
PVC | Material

12
14
14
26

PCA-S12
Waterproof Sealant
6,8,10mm | Glass Thickness
300,220cm | Length
PVC | Material

30
14
16
14

PCA-S15
Waterproof Sealant Glued
6,8,10mm | Glass Thickness
220cm | Length
PVC | Material

4
5

PCA-S27
Waterproof Sealant Glued
8mm | Glass Thickness
220cm | Length
PVC | Material

8
14
8

PCA-S28
Waterproof Sealant 180° Magnet
8mm | Glass Thickness
220cm | Length
PVC | Material

8
25
8



NEW BLACK SHOWER CABIN SEALANTS

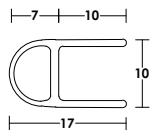

PCA-S05-BK
Waterproof Sealant
 8mm | Glass Thickness
 300,220cm | Length
 PVC | Material

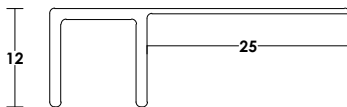

PCA-S06-BK
Waterproof Sealant
 8,10mm | Glass Thickness
 300,220cm | Length
 25mm | Wing Length
 PVC | Material

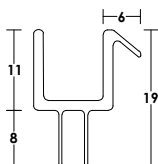

PCA-S07-BK
Bottom Waterproof Sealant
 8,10mm | Glass Thickness
 300,220cm | Length
 8mm | Wing Length
 PVC | Material

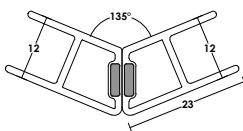

PCA-S08-BK
Waterproof Sealant 135° Magnet
 8,10mm | Glass Thickness
 300,220cm | Length
 PVC | Material

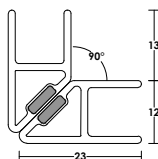

PCA-S09-BK
Waterproof Sealant 90° Magnet
 8,10mm | Glass Thickness
 300,220cm | Length
 PVC | Material

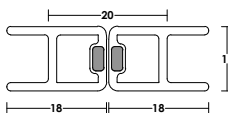

PCA-S10-BK
Waterproof Sealant 180° Magnet
 8,10mm | Glass Thickness
 300,220cm | Length
 PVC | Material

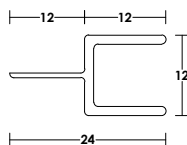

PCA-S11-BK
Waterproof Sealant
 10mm | Glass Thickness
 300,220cm | Length
 12mm | Wing Length
 PVC | Material

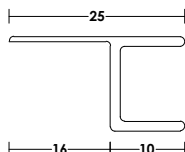

PCA-S12-BK
Waterproof Sealant
 8,10mm | Glass Thickness
 300,220cm | Length
 16mm | Wing Length
 PVC | Material



PCA-SH31
Glass - Wall Hinge
 10mm | Glass Thickness
 40 kg | Max. Weight
 Zinc Alloy,Stainless Steel 304| Material
 Satin, Polished, Black Anodize | Finish

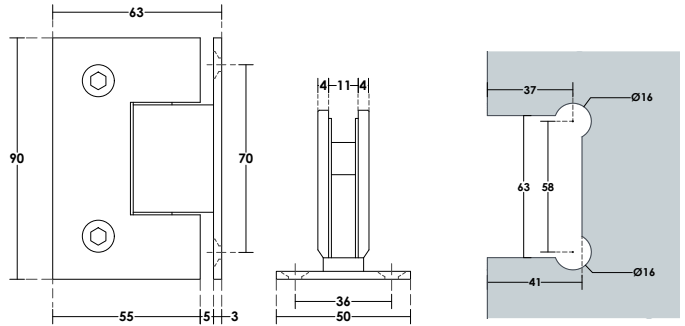

PCA-SH33
Glass - Wall Hinge
 10mm | Glass Thickness
 40 kg | Max. Weight
 Zinc Alloy,Stainless Steel 304| Material
 Satin, Polished, Black Anodize | Finish

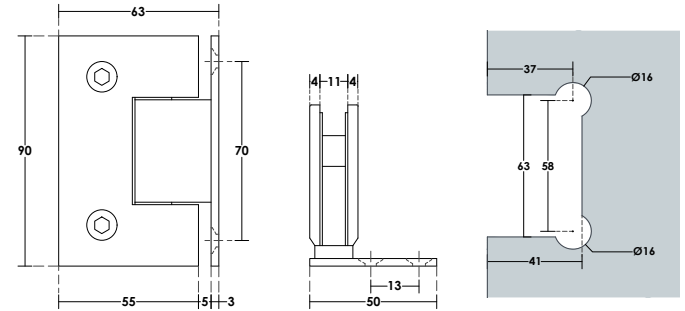

PCA-SH35
135° Glass - Glass Hinge
 10mm | Glass Thickness
 40 kg | Max. Weight
 Zinc Alloy,Stainless Steel 304| Material
 Satin, Polished, Black Anodize | Finish

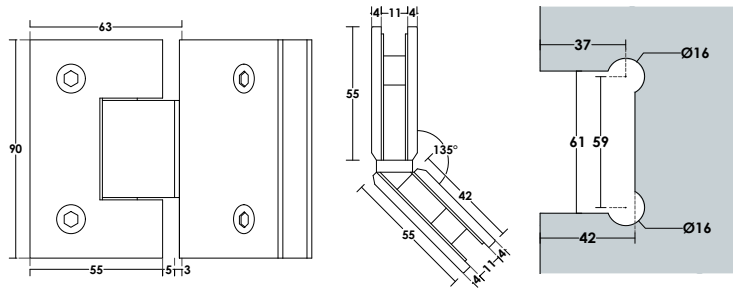

SH35 REQUIRES 45° GLASS GRINDING



PCA-SH36
180° Glass - Glass Hinge
 10mm | Glass Thickness
 40 kg | Max. Weight
 Zinc Alloy,Stainless Steel 304| Material
 Satin, Polished, Black Anodize | Finish

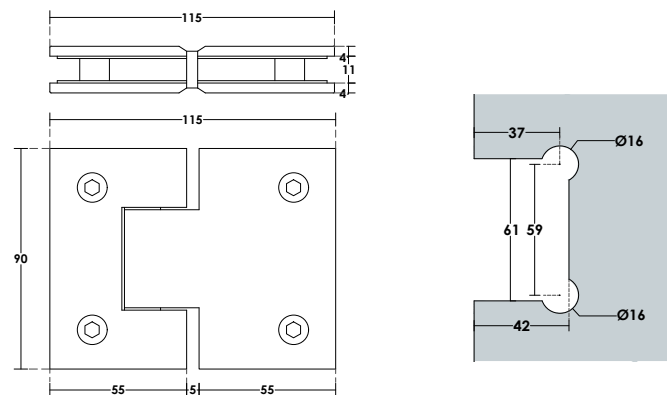

PCA-SH37
90° Glass - Glass Hinge
 10mm | Glass Thickness
 40 kg | Max. Weight
 Zinc Alloy,Stainless Steel 304| Material
 Satin, Polished, Black Anodize | Finish

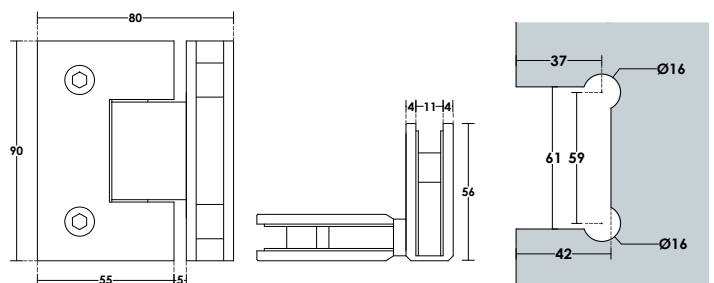

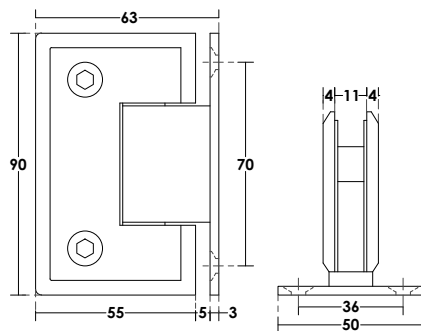
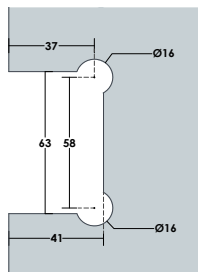

PCA-SH01
Glass - Wall Hinge
 10mm | Glass Thickness
 40 kg | Max. Weight
 Zinc Alloy, Stainless Steel 304 | Material
 Satin, Polished, Black Anodize | Finish

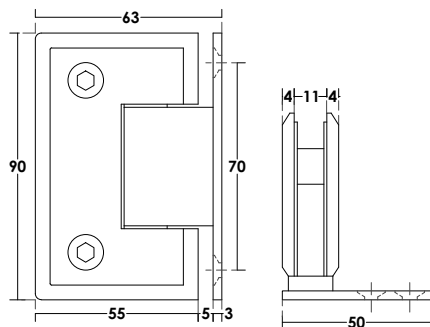
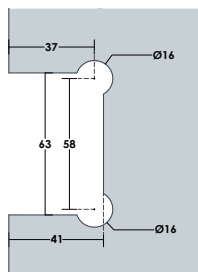

PCA-SH03
Glass - Wall Hinge
 10mm | Glass Thickness
 40 kg | Max. Weight
 Zinc Alloy, Stainless Steel 304 | Material
 Satin, Polished, Black Anodize | Finish

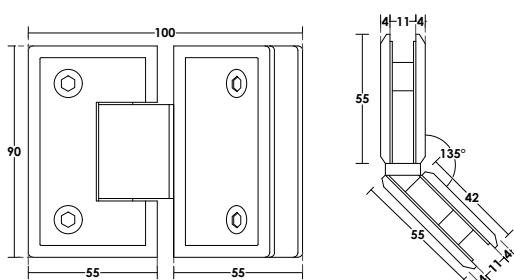
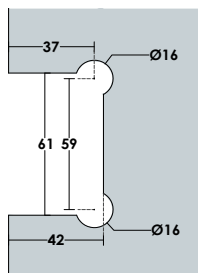

PCA-SH05
135° Glass - Glass Hinge
 10mm | Glass Thickness
 40 kg | Max. Weight
 Zinc Alloy, Stainless Steel 304 | Material
 Satin, Polished, Black Anodize | Finish



 SH35 REQUIRES 45° GLASS GRINDING

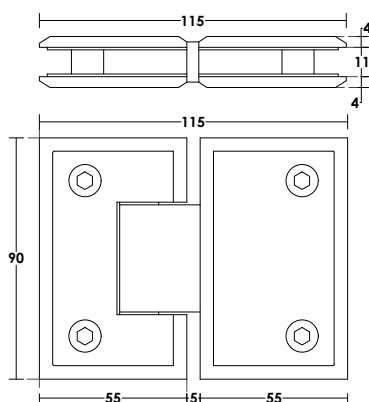
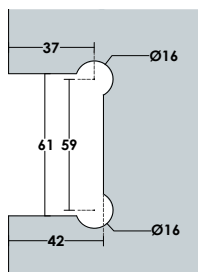

PCA-SH06
180° Glass - Glass Hinge
 10mm | Glass Thickness
 40 kg | Max. Weight
 Zinc Alloy, Stainless Steel 304 | Material
 Satin, Polished, Black Anodize | Finish

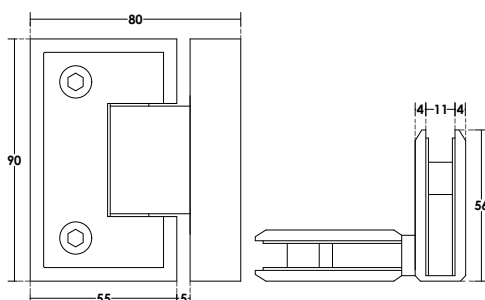
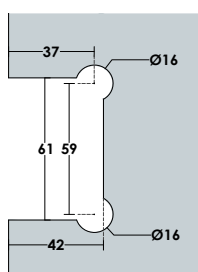

PCA-SH07
90° Glass - Glass Hinge
 10mm | Glass Thickness
 40 kg | Max. Weight
 Zinc Alloy, Stainless Steel 304 | Material
 Satin, Polished, Black Anodize | Finish



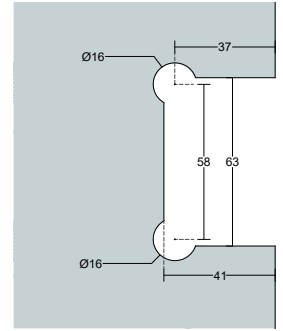
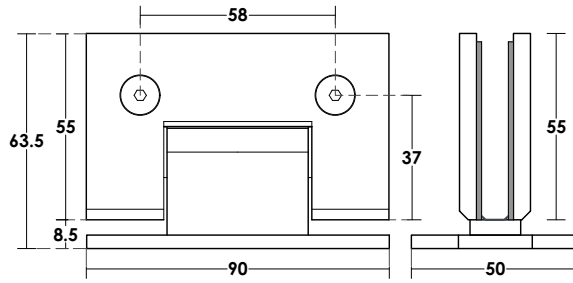

PCA-SH49

Glass - Wall Hinge

10-12mm | Glass Thickness

50 kg | Max. Weight

Brass | Material

Satin, Polished, Black Anodize | Finish



Double action 90°

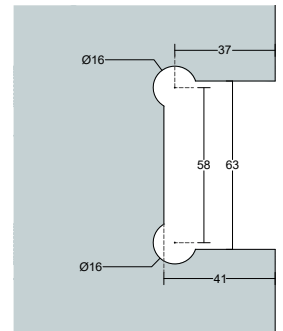
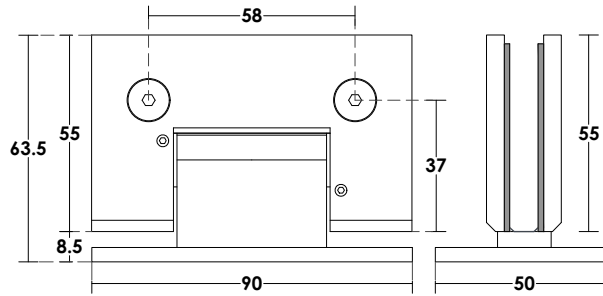

PCA-SH50

Adjustable Glass - Wall Hinge

8-10mm | Glass Thickness

45 kg | Max. Weight

Brass | Material

Satin, Polished | Finish



Double action 90°
Adjustable corner from 0° to 10°

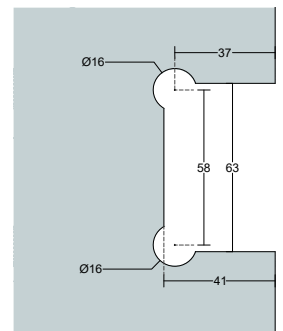
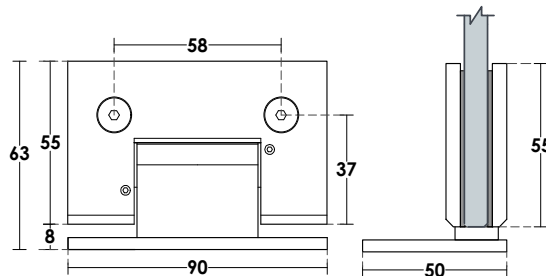

PCA-SH51

Glass - Wall Hinge

8-10mm | Glass Thickness

45 kg | Max. Weight

Brass | Material

Satin, Polished | Finish



Hidden screw
Double action 90°
Adjustable corner from 0° to 10°

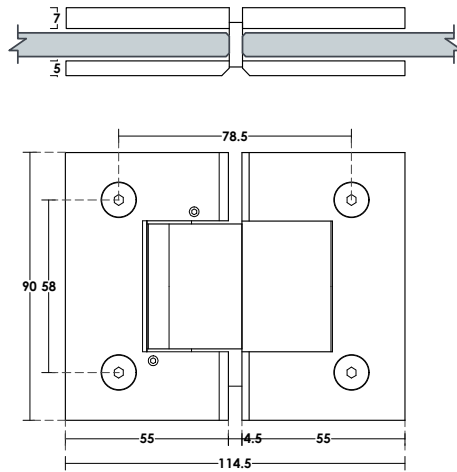
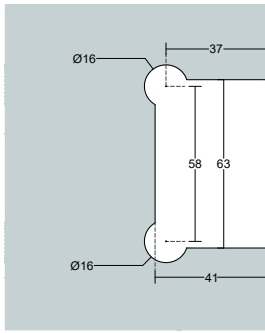

Double action 90°
Adjustable corner from 0° to 10°

PCA-SH52
180° Adjustable Glass - Glass Hinge
8-10mm | Glass Thickness
45 kg | Max. Weight
Brass | Material
Satin, Polished | Finish

HIDDEN SCREWS - MINIMAL VIEW

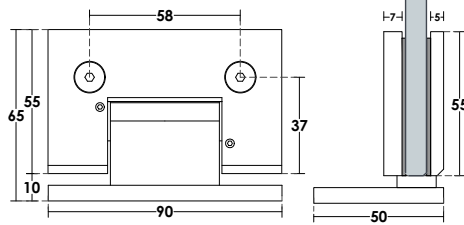
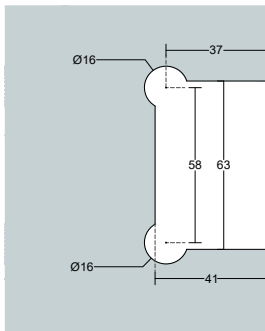

Sliding cover

PCA-SH53
Glass - Wall Hinge
8-10mm | Glass Thickness
45 kg | Max. Weight
Brass | Material
Satin, Polished | Finish

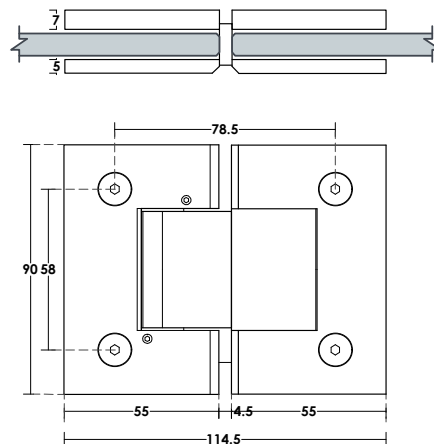
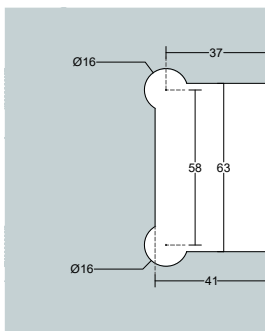

PCA-SH54
180° Glass - Glass Hinge
8-10mm | Glass Thickness
45 kg | Max. Weight
Brass | Material
Satin, Polished | Finish

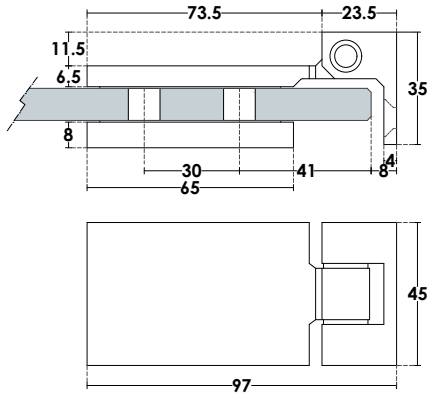

Glass Cut

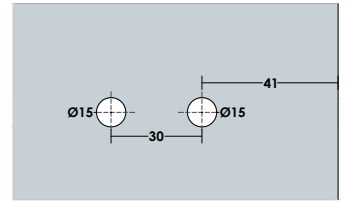

PCA-SH45

Glass - Wall Hinge

10mm | Glass Thickness
40 kg | Max. Weight
Stainless Steel 304 | Material
Satin, Polished, Black Anodize | Finish

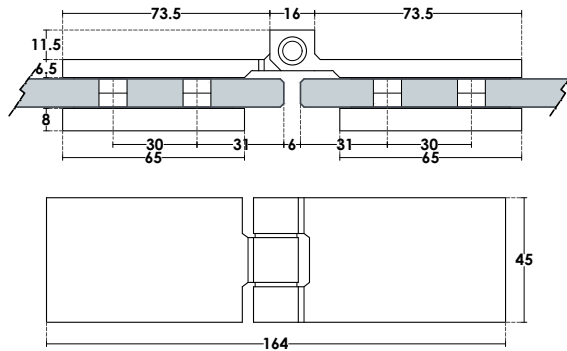

Glass Cut

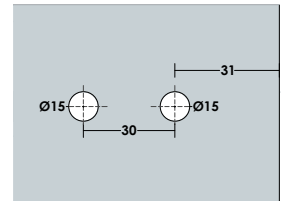

PCA-SH46

Glass - Glass Hinge

10mm | Glass Thickness
40 kg | Max. Weight
Stainless Steel 304 | Material
Satin, Polished, Black Anodize | Finish

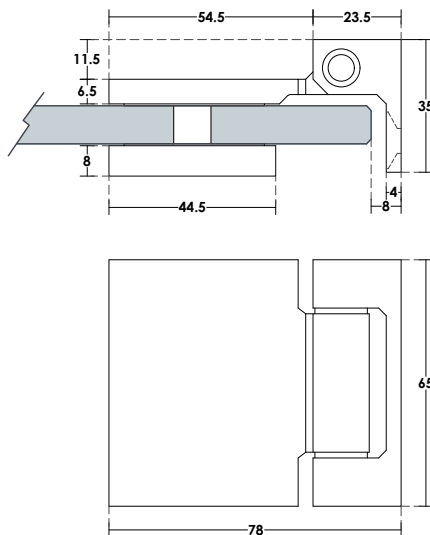

Glass Cut

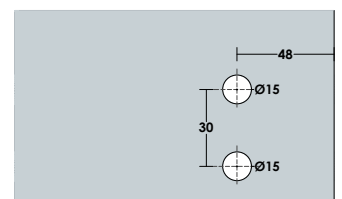

PCA-SH47

Glass - Wall Hinge

10mm | Glass Thickness
40 kg | Max. Weight
Stainless Steel 304 | Material
Satin, Polished, Black Anodize | Finish



Glass Cut

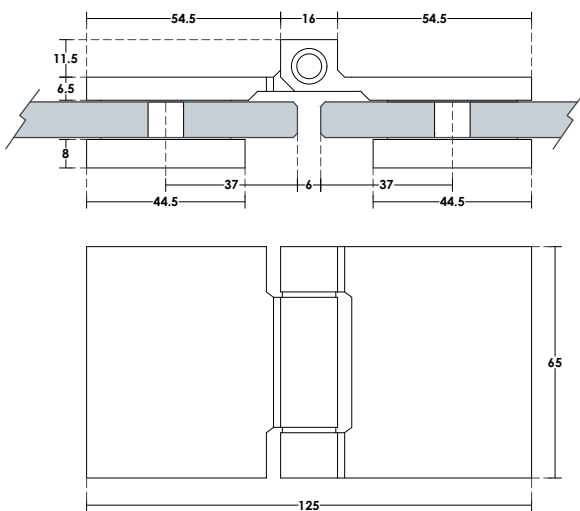
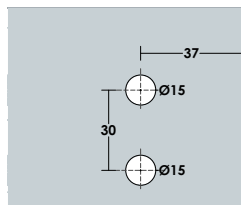

PCA-SH48
Glass - Glass Hinge
 10mm | Glass Thickness
 40 kg | Max. Weight
 Stainless Steel 304 | Material
 Satin, Polished, Black Anodize | Finish



Glass Cut

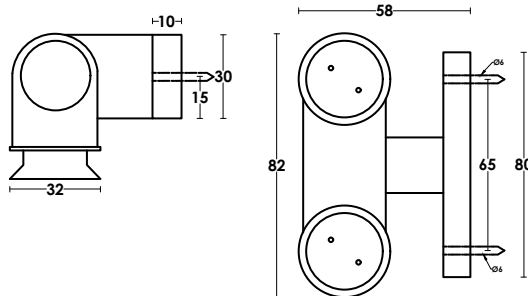
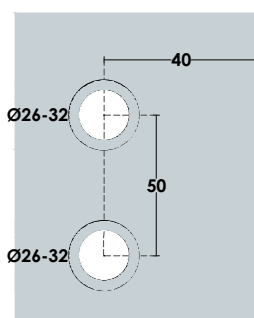

PCA-SH17
Glass - Wall Hinge
 10mm | Glass Thickness
 40 kg | Max. Weight
 Stainless Steel 304 | Material
 Satin | Finish

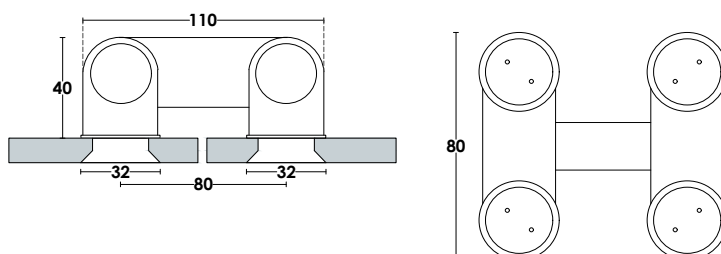
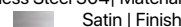

PCA-SH18
Glass - Glass Hinge
 10mm | Glass Thickness
 40 kg | Max. Weight
 Stainless Steel 304 | Material
 Satin | Finish

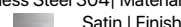

Glass Cut

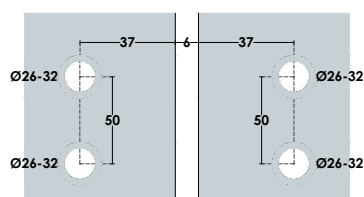

HYDRAULIC GLASS DOOR HINGE

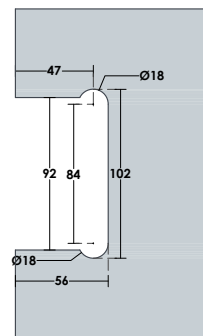
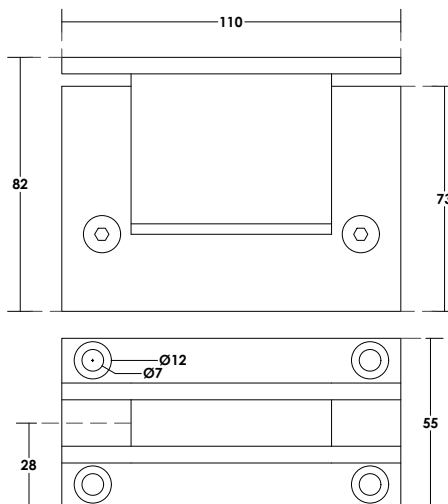

NEW

Glass Cut

PCA-SH55

Hydraulic Hinge

8-14mm | Glass Thickness
 60 kg | Max. Door Weight
 95° double action | Max. Opening Angle
 240cm | Max. Door Height
 100cm | Max. Door Width
 Stainless Steel | Material
 Satin, Polished | Finish

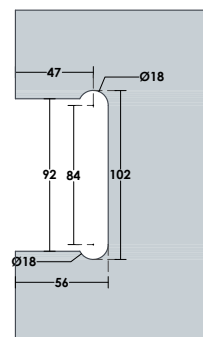
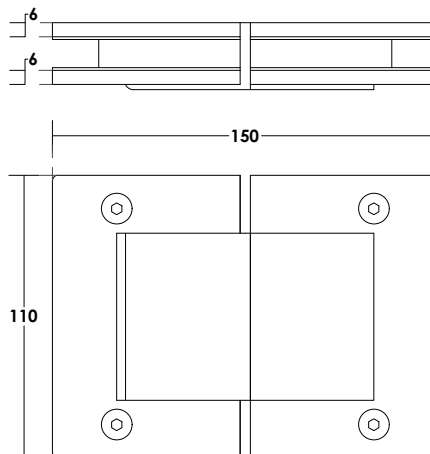

NEW

Glass Cut

PCA-SH56

Hydraulic Hinge

8-14mm | Glass Thickness
 60 kg | Max. Door Weight
 95° double action | Max. Opening Angle
 240cm | Max. Door Height
 100cm | Max. Door Width
 Stainless Steel | Material
 Satin, Polished | Finish

- Set of 1 spring hinge and 1 hydraulic hinge.
- The spring glass hinge is for restoring, hydraulic glass hinge is for soft closing, speed adjustable.
- 90° - 95° hold open function is optional.
- Easy installation, the installation method is same as normal glass hinge.
- Excellent durability, precision manufacturing technology.

PIVOT GLASS DOOR HINGE



PCA-SH20

Top or Bottom Mount Pivot Hinge

8-10mm | Glass Thickness

45 kg | Max. Weight

Brass | Material

Satin, Polished | Finish

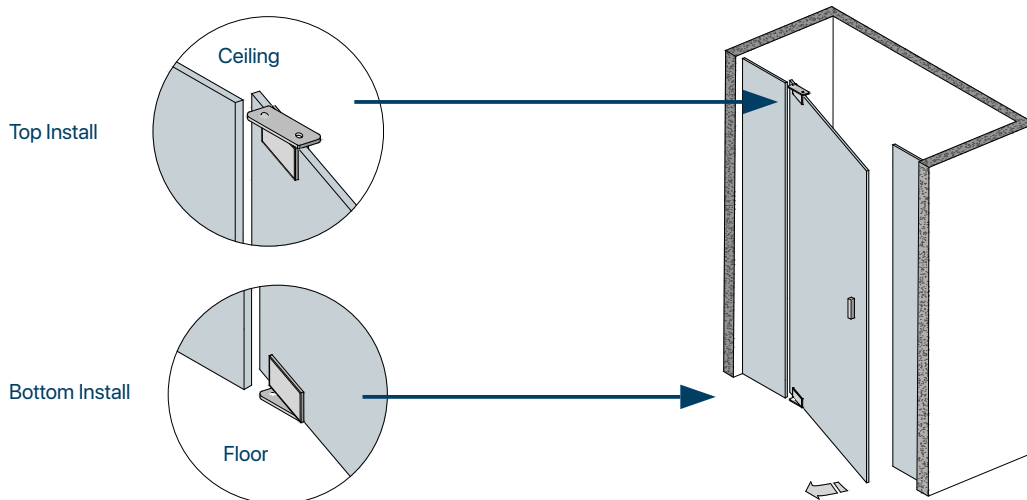
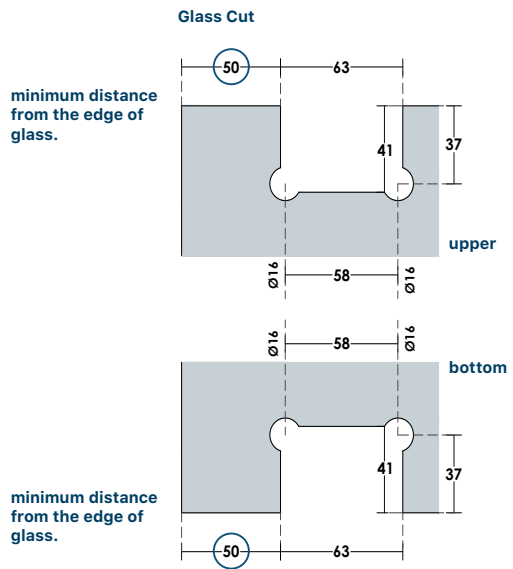
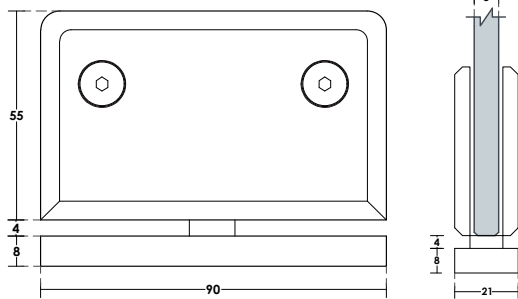



PCA-GC01

Glass - Wall Clamp

10mm | Glass Thickness
 30 kg | Max. Weight
 Zinc Alloy,Stainless Steel 304| Material
 Satin, Polished | Finish

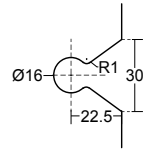
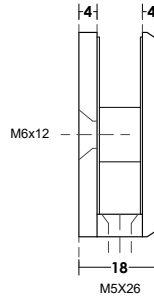
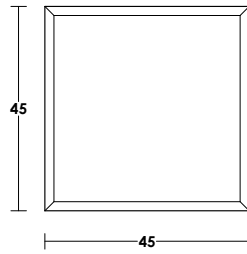

Glass Cut



PCA-GC03

Glass - Wall Clamp

10mm | Glass Thickness
 30 kg | Max. Weight
 Zinc Alloy,Stainless Steel 304| Material
 Satin, Polished | Finish

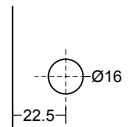
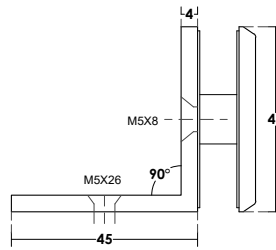
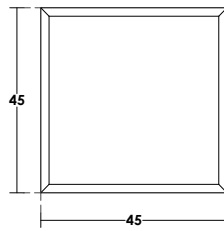

Glass Cut



PCA-GC05

90° Glass - Glass Clamp

10mm | Glass Thickness
 30 kg | Max. Weight
 Zinc Alloy,Stainless Steel 304| Material
 Satin, Polished | Finish

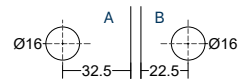
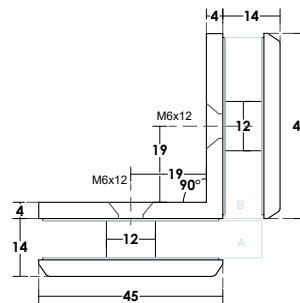
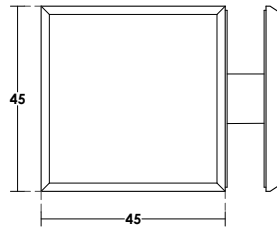

Glass Cut



PCA-GC06

135° Glass - Glass Clamp

10mm | Glass Thickness
 30 kg | Max. Weight
 Zinc Alloy,Stainless Steel 304| Material
 Satin, Polished | Finish

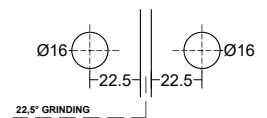
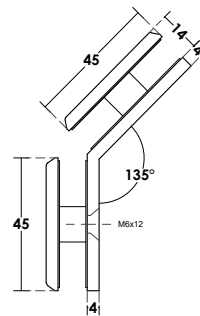
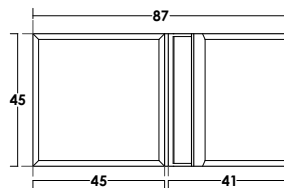

Glass Cut



PCA-GC07

180° Glass - Glass Clamp

10mm | Glass Thickness
 30 kg | Max. Weight
 Zinc Alloy,Stainless Steel 304| Material
 Satin, Polished | Finish

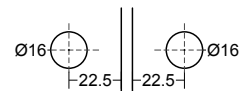
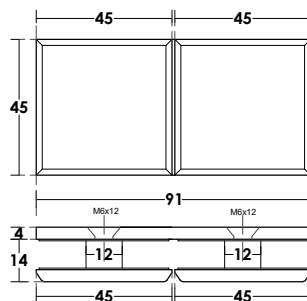

Glass Cut

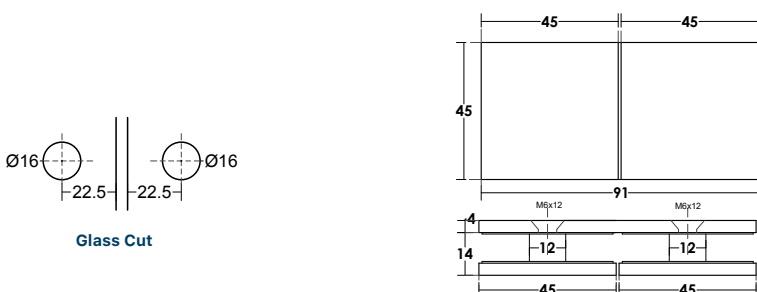
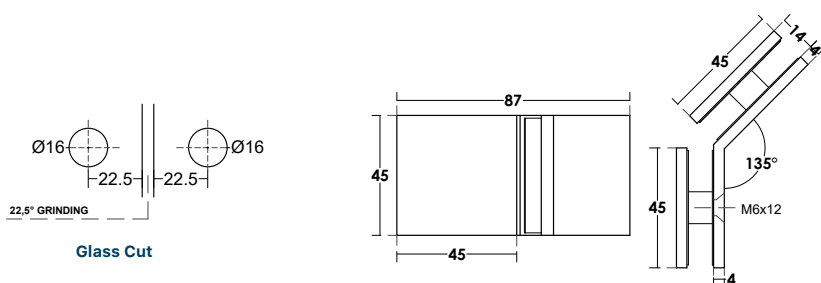
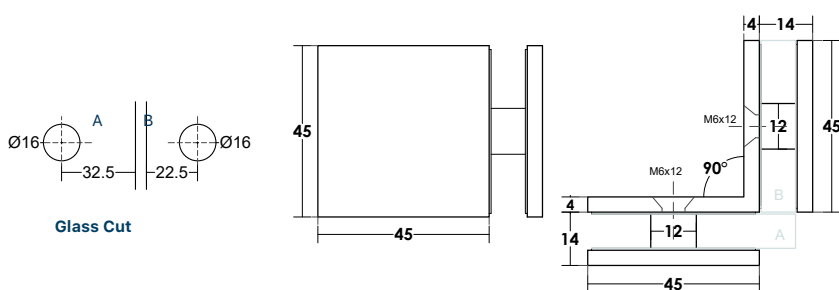
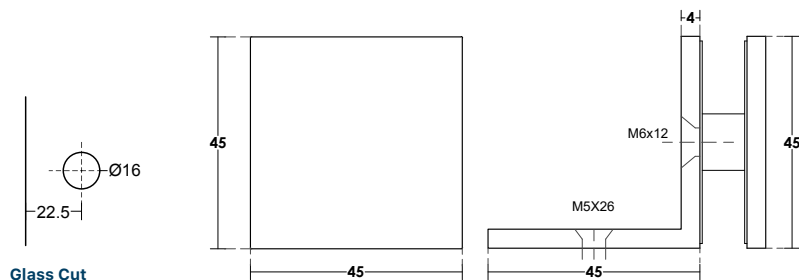
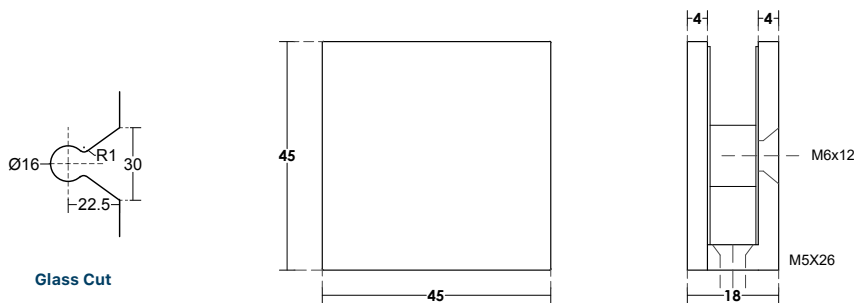



PCA-GC40

Glass - Wall Clamp

8,10mm | Glass Thickness
 30 kg | Max. Weight
 Brass | Material
 Satin, Polished | Finish

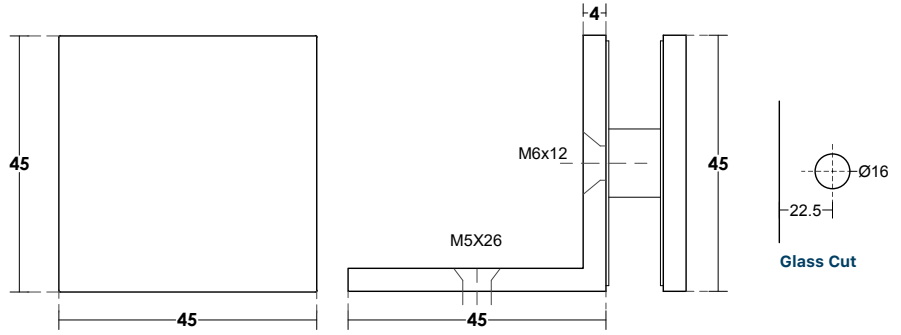

PCA-GC41

Adjustable 90°-180° Glass Clamp

6-10mm | Glass Thickness
 30 kg | Max. Weight
 Brass | Material
 Satin, Polished | Finish

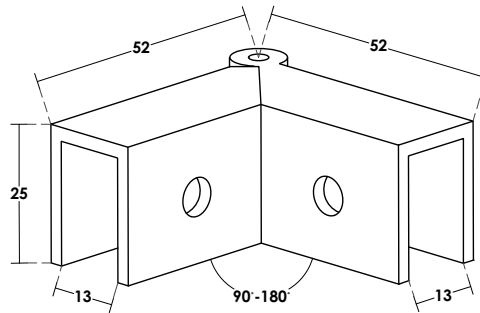

PCA-GC42 L

Wall Mount Glass Clamp

6-10mm | Glass Thickness
 30 kg | Max. Weight
 Brass | Material
 Satin, Polished | Finish

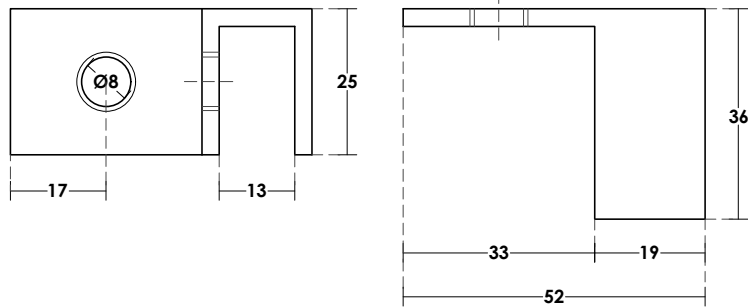

PCA-GC42 R

Wall Mount Glass Clamp

6-10mm | Glass Thickness
 30 kg | Max. Weight
 Brass | Material
 Satin, Polished | Finish

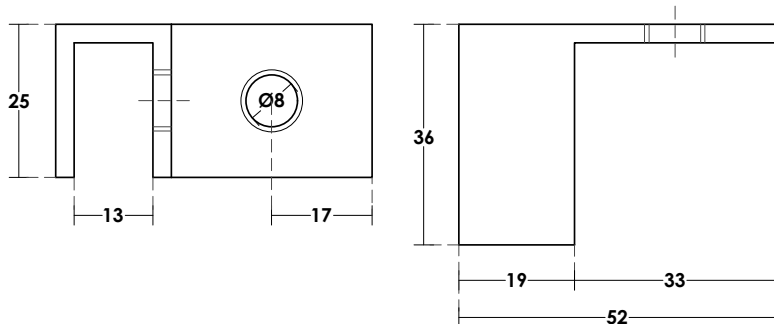

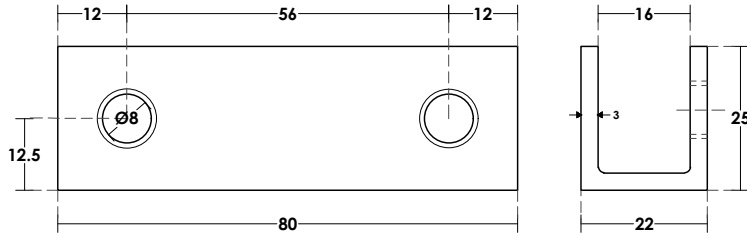

PCA-GC43
Glass - Glass Clamp
 10-12mm | Glass Thickness
 30 kg | Max. Weight
 Stainless Steel 304 | Material
 Satin, Polished | Finish

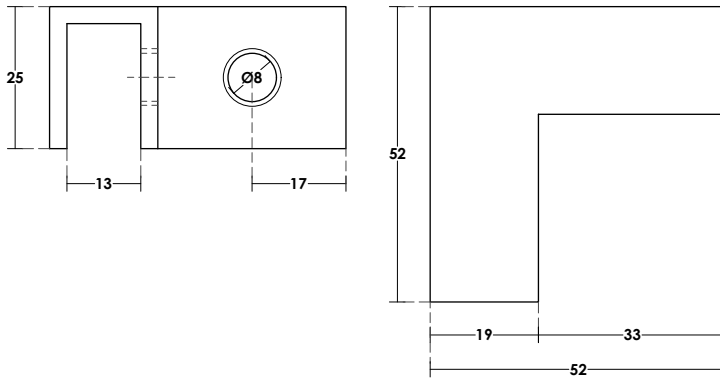

PCA-GC44
Glass - Glass Clamp
 10mm | Glass Thickness
 30 kg | Max. Weight
 Stainless Steel 304 | Material
 Satin, Polished | Finish

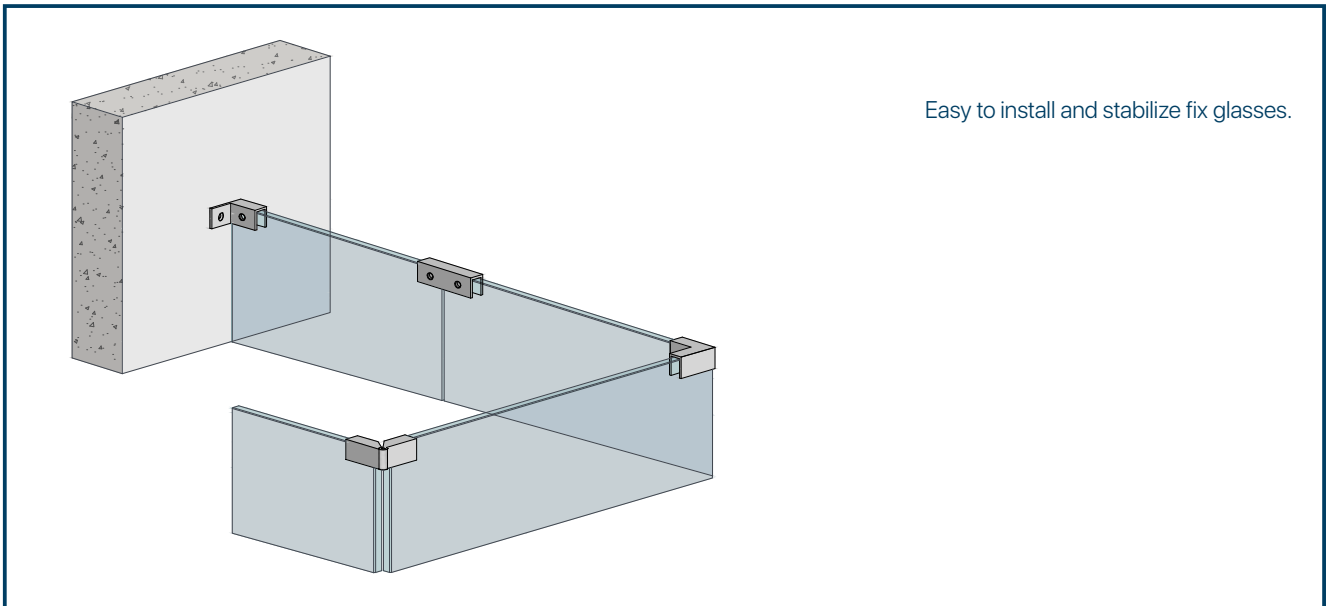

Easy to install and stabilize fix glasses.



PCA-BL15
Bolt with Indicator
 8-12mm | Glass Thickness
 Stainless Steel 304 | Material
 Satin | Finish

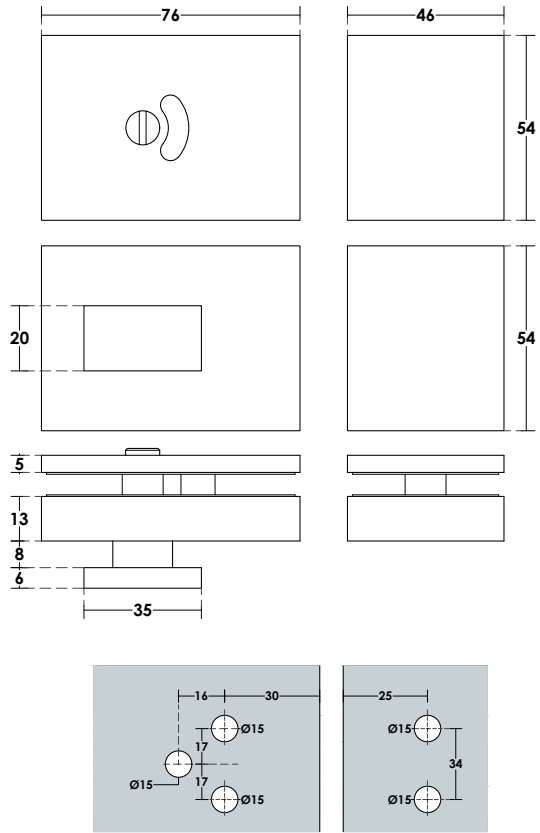

Glass Cut



PCA-BL16
Bolt with Indicator
 8-12mm | Glass Thickness
 Stainless Steel 304 | Material
 Satin | Finish

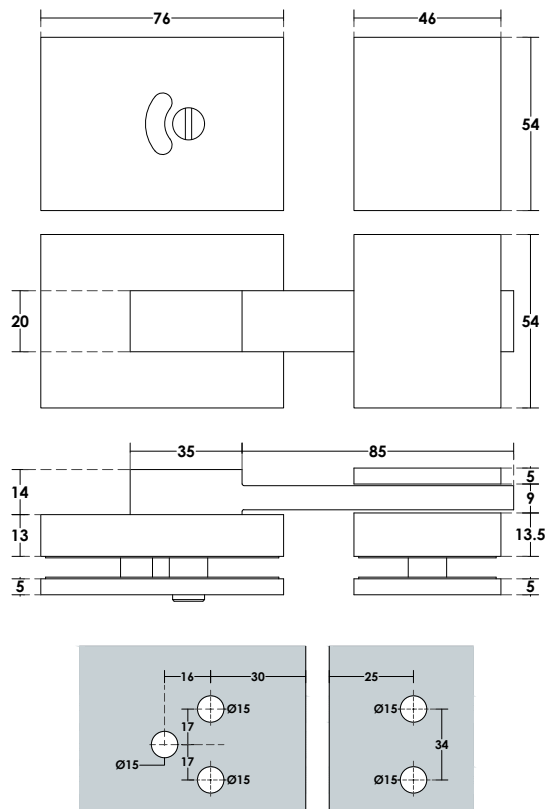

Glass Cut

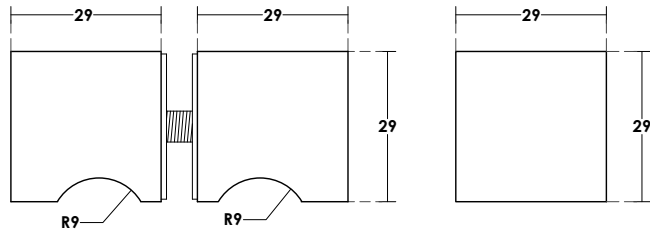
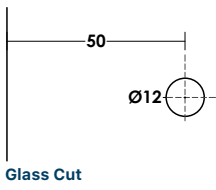

PCA-DK20
Door Knob

8-12mm | Glass Thickness
Stainless Steel 304 | Material
Satin, Polished | Finish

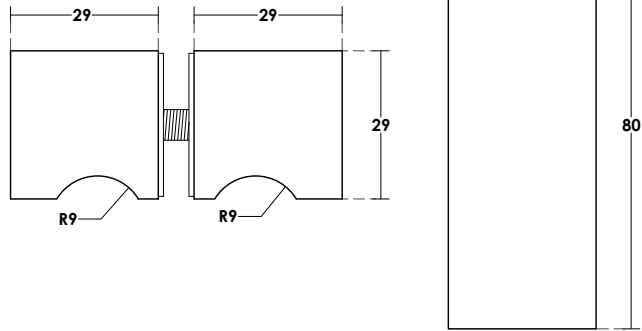
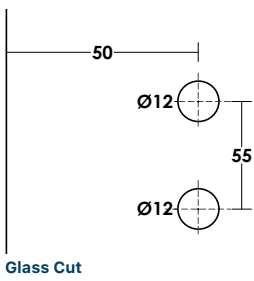

PCA-DK21
Door Knob

8-12mm | Glass Thickness
Stainless Steel 304 | Material
Satin, Polished | Finish

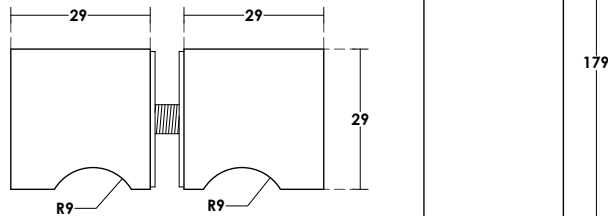
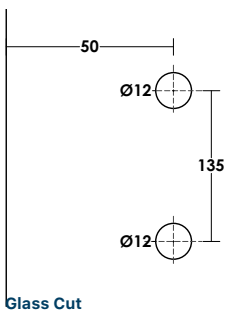

PCA-DK22
Door Knob

8-12mm | Glass Thickness
Stainless Steel 304 | Material
Satin, Polished | Finish



PCA-DK03
Sliding Door Knob
8-12mm | Glass Thickness
Stainless Steel 304 | Material
Satin, Polished | Finish

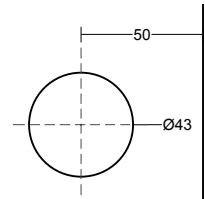
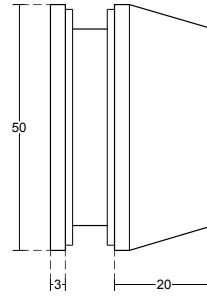
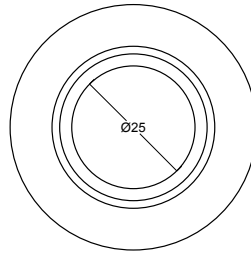

Glass Cut



PCA-DK06
Sliding Door Knob
8-12mm | Glass Thickness
Stainless Steel 304 | Material
Satin, Polished | Finish

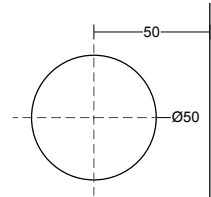
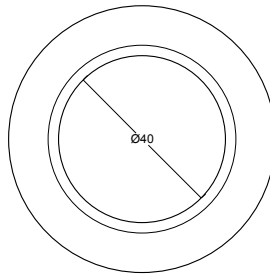

Glass Cut



PCA-DK08
Sliding Door Knob
8-12mm | Glass Thickness
Aluminium, Stainless Steel 304 | Material
Satin, Black | Finish

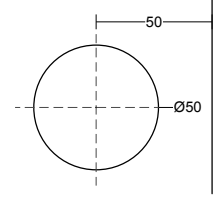
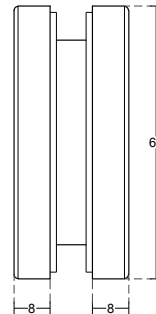
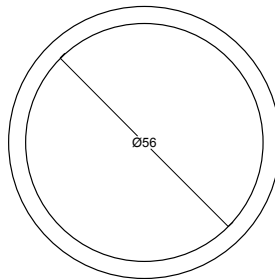

Glass Cut



PCA-DK08S
Sliding Door Knob - Glued
Aluminium | Material
Natural Anodize | Finish

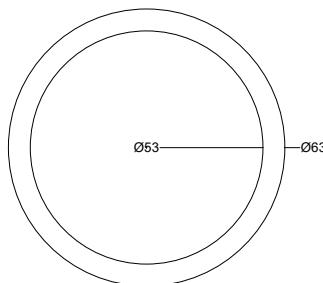

Glued

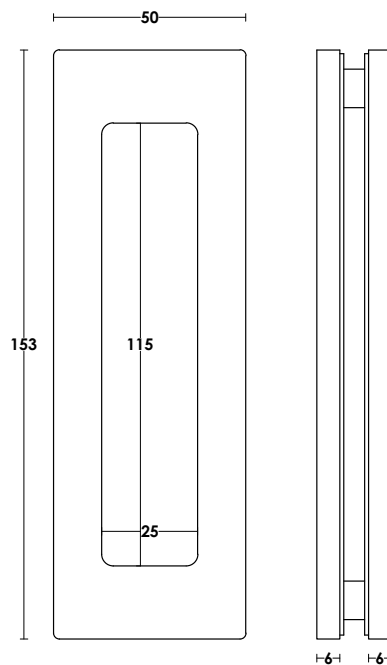
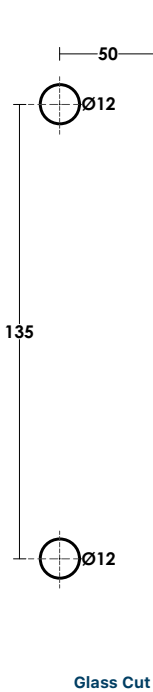
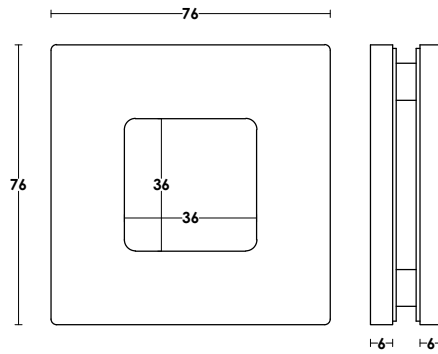
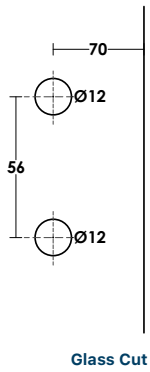
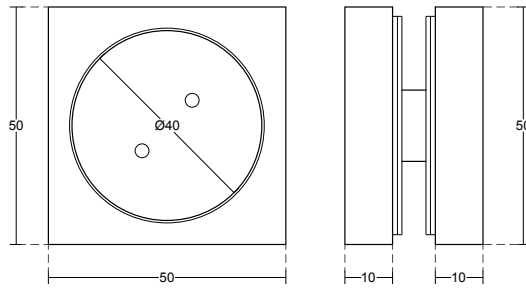
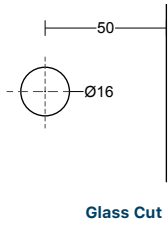



PCA-DK13A
Door Knob

8-12mm | Glass Thickness
Zinc Alloy, Brass | Material
Satin, Polished | Finish

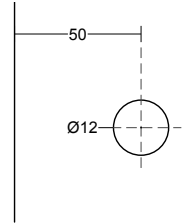
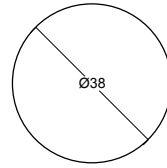
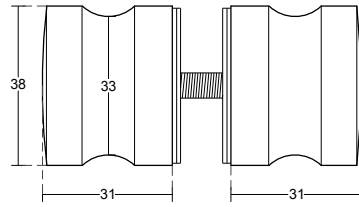

Glass Cut



PCA-DK13B
Door Knob

8-12mm | Glass Thickness
Zinc Alloy, Brass | Material
Satin, Polished | Finish

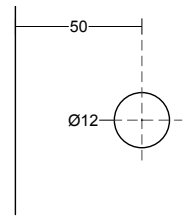
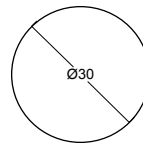
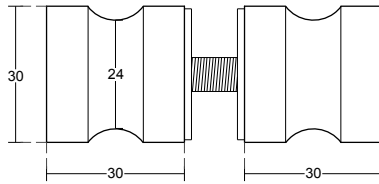

Glass Cut



PCA-DK14
Door Knob

8-12mm | Glass Thickness
Zinc Alloy, Brass | Material
Satin, Polished | Finish

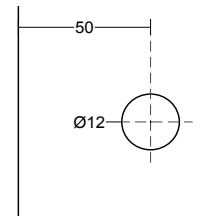
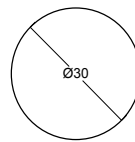
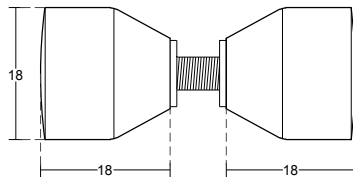

Glass Cut



PCA-DK16
Door Knob

8-12mm | Glass Thickness
Zinc Alloy, Brass | Material
Satin, Polished | Finish

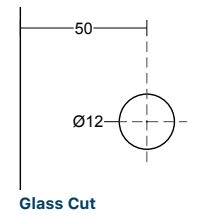
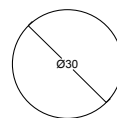
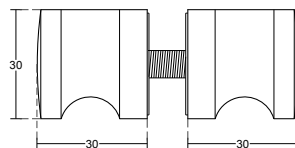

Glass Cut

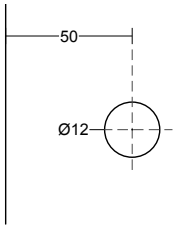

Glass Cut

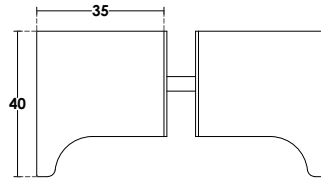

PCA-DK15
Door Knob

8-12mm | Glass Thickness
Brass | Material

■ ■ Satin, Polished | Finish

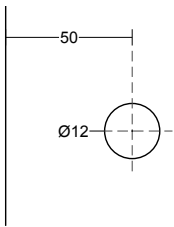

Glass Cut

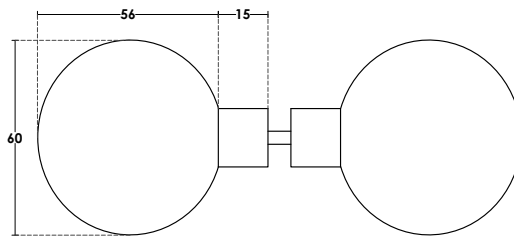

PCA-DK11
Door Knob

8-12mm | Glass Thickness
Brass | Material

■ Satin | Finish

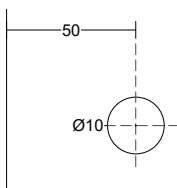

Glass Cut

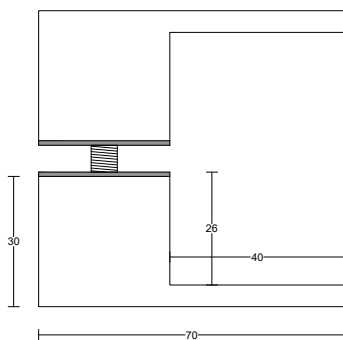

PCA-DK24
Door Knob

6-12mm | Glass Thickness
Brass | Material

■ ■ ■ Satin, Polished, Black Anodize | Finish

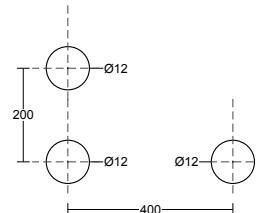
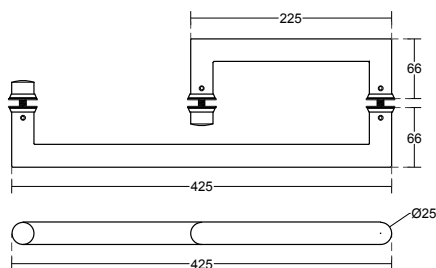

Glass Cut

PCA-HS03

Ø25mm Shower Cabin Handle

8-12mm | Glass Thickness
 Stainless Steel 304 | Material
 Satin, Polished | Finish

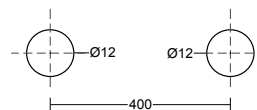
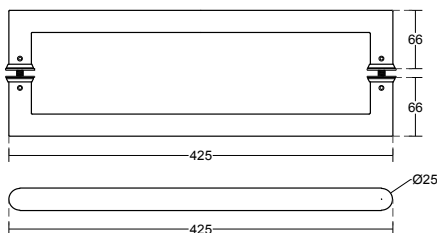

Glass Cut

PCA-HS04

Ø25mm Shower Cabin Handle

8-12mm | Glass Thickness
 Stainless Steel 304 | Material
 Satin, Polished | Finish

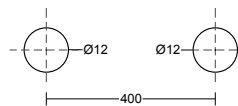
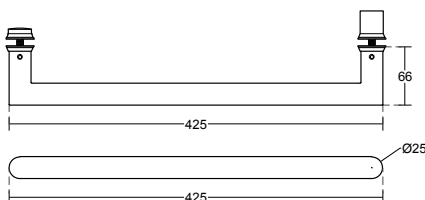

Glass Cut

PCA-HS05

Ø25mm Shower Cabin Handle

8-12mm | Glass Thickness
 Stainless Steel 304 | Material
 Satin, Polished | Finish

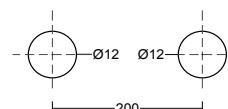
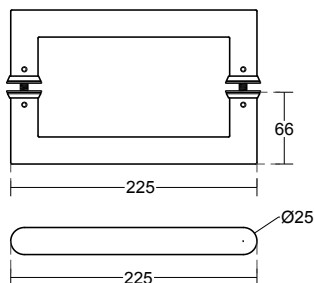

Glass Cut

PCA-HS06

Ø25mm Shower Cabin Handle

8-12mm | Glass Thickness
 Stainless Steel 304 | Material
 Satin, Polished | Finish



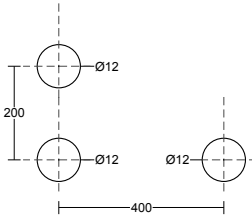

Glass Cut

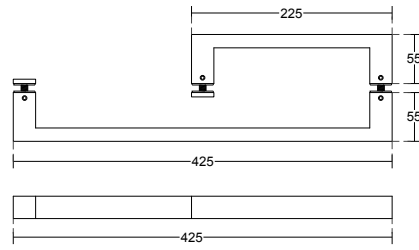

PCA-HS10
25x15mm Shower Cabin Handle
 8-12mm | Glass Thickness
 Stainless Steel 304 | Material
 Satin, Polished | Finish

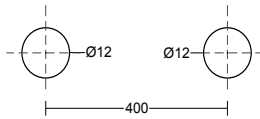

Glass Cut

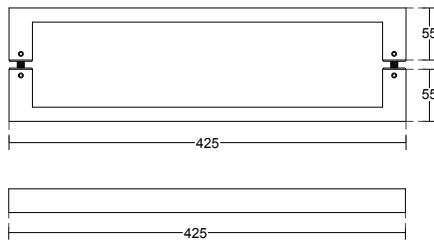

PCA-HS08
25x15mm Shower Cabin Handle
 8-12mm | Glass Thickness
 Stainless Steel 304 | Material
 Satin, Polished | Finish

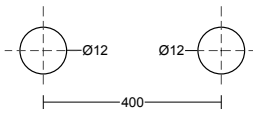

Glass Cut

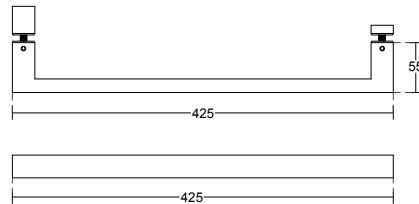

PCA-HS07
25x15mm Shower Cabin Handle
 8-12mm | Glass Thickness
 Stainless Steel 304 | Material
 Satin, Polished | Finish

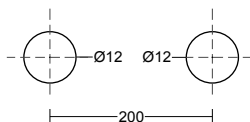

Glass Cut

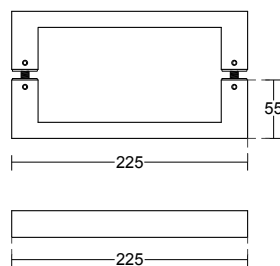

PCA-HS09
25x15mm Shower Cabin Handle
 8-12mm | Glass Thickness
 Stainless Steel 304 | Material
 Satin, Polished | Finish

PCA-BR01

Support Bar Glass - Glass
 8-12mm | Glass Thickness
 Stainless Steel 304 | Material
 Satin, Polished | Finish

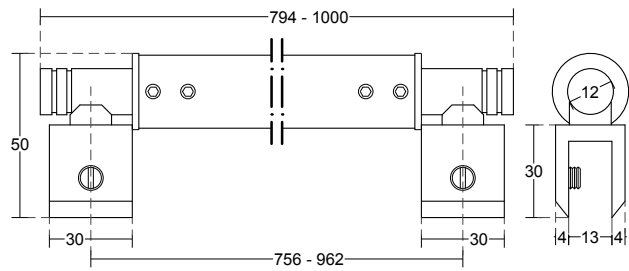

PCA-BR02

Support Bar Wall - Glass
 8-12mm | Glass Thickness
 Stainless Steel 304 | Material
 Satin, Polished | Finish

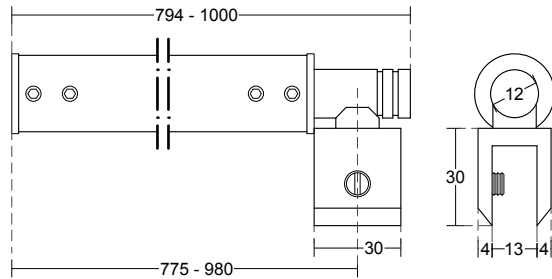

PCA-BR03

Corner Support Bar Wall - Glass
 8-12mm | Glass Thickness
 Stainless Steel 304 | Material
 Satin, Polished | Finish

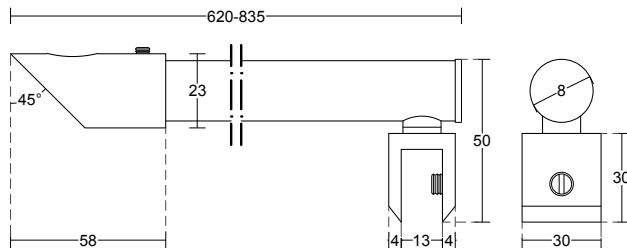

PCA-BR04

Corner Support Bar Wall - Glass
 8-12mm | Glass Thickness
 Stainless Steel 304 | Material
 Satin, Polished | Finish

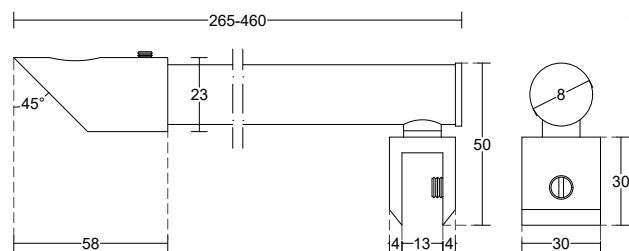

Shower Cabins & WC Partitions	8
Doors & Office Partitions	81
Facades	169
Folding	199
Guillotine	209
Spiders	215
Balcony Railings	225
Inox Railings	273
Staircase	293
Canopies	297
Miscellaneous & Consumables	307



SOFTCLOSE SLIDING DOOR SERIES | D

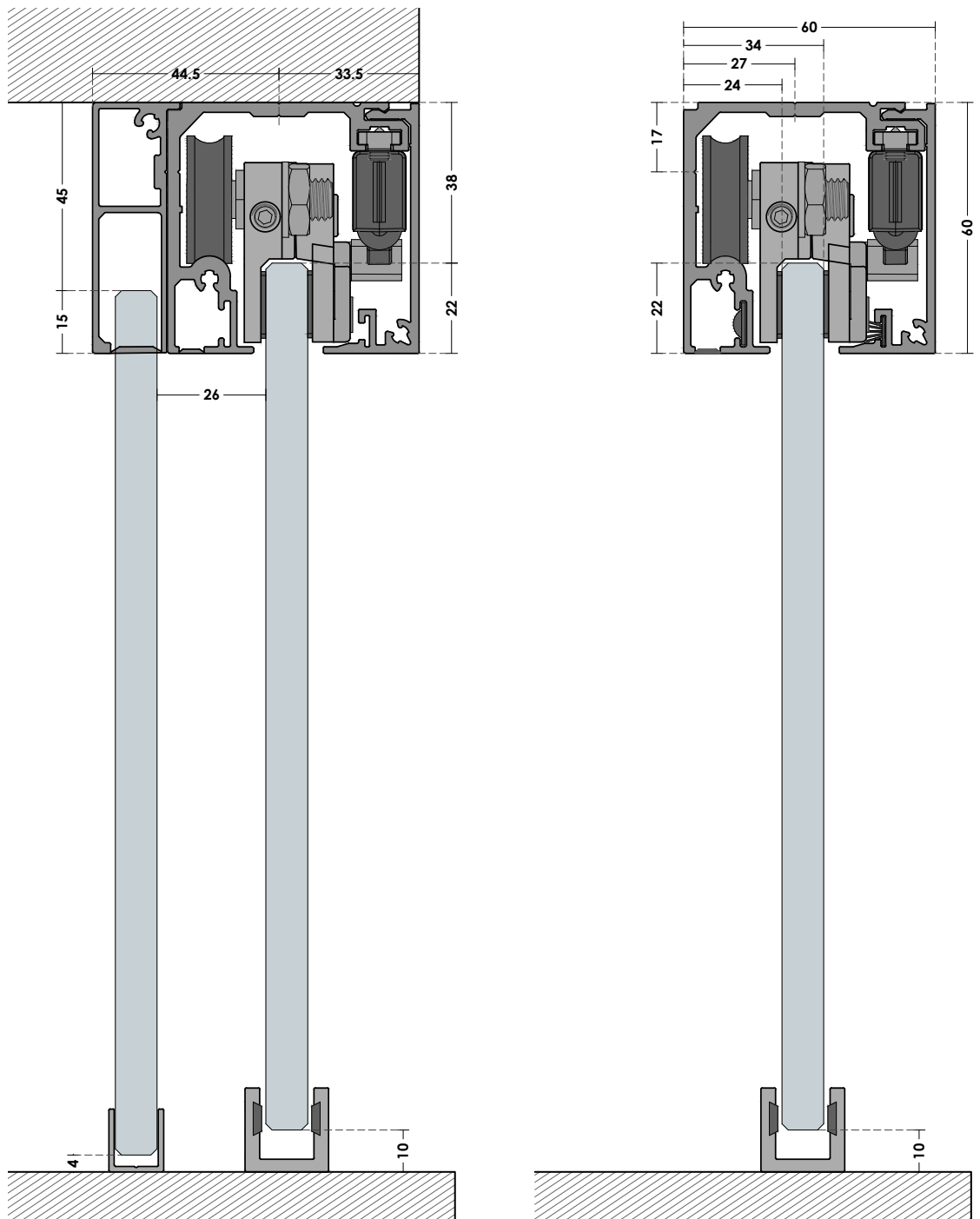

SPECIFICATIONS

GLASS THICKNESS : 10 mm

MAX. LOAD : 80kg

FUNCTION : SOFTCLOSE

MATERIAL : Aluminium

FINISH : Satin, Natural Anodize & Black Anodize



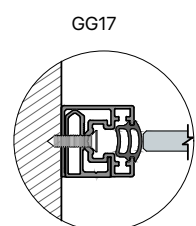
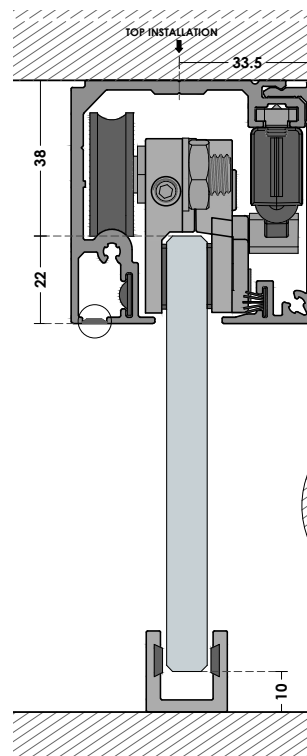
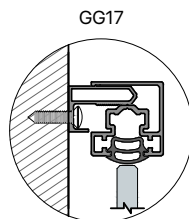
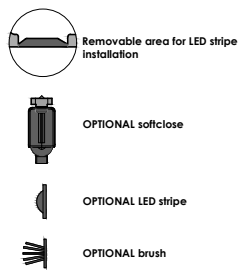
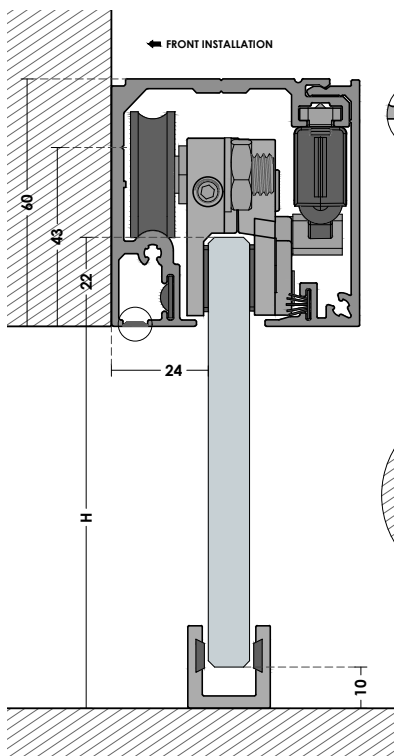
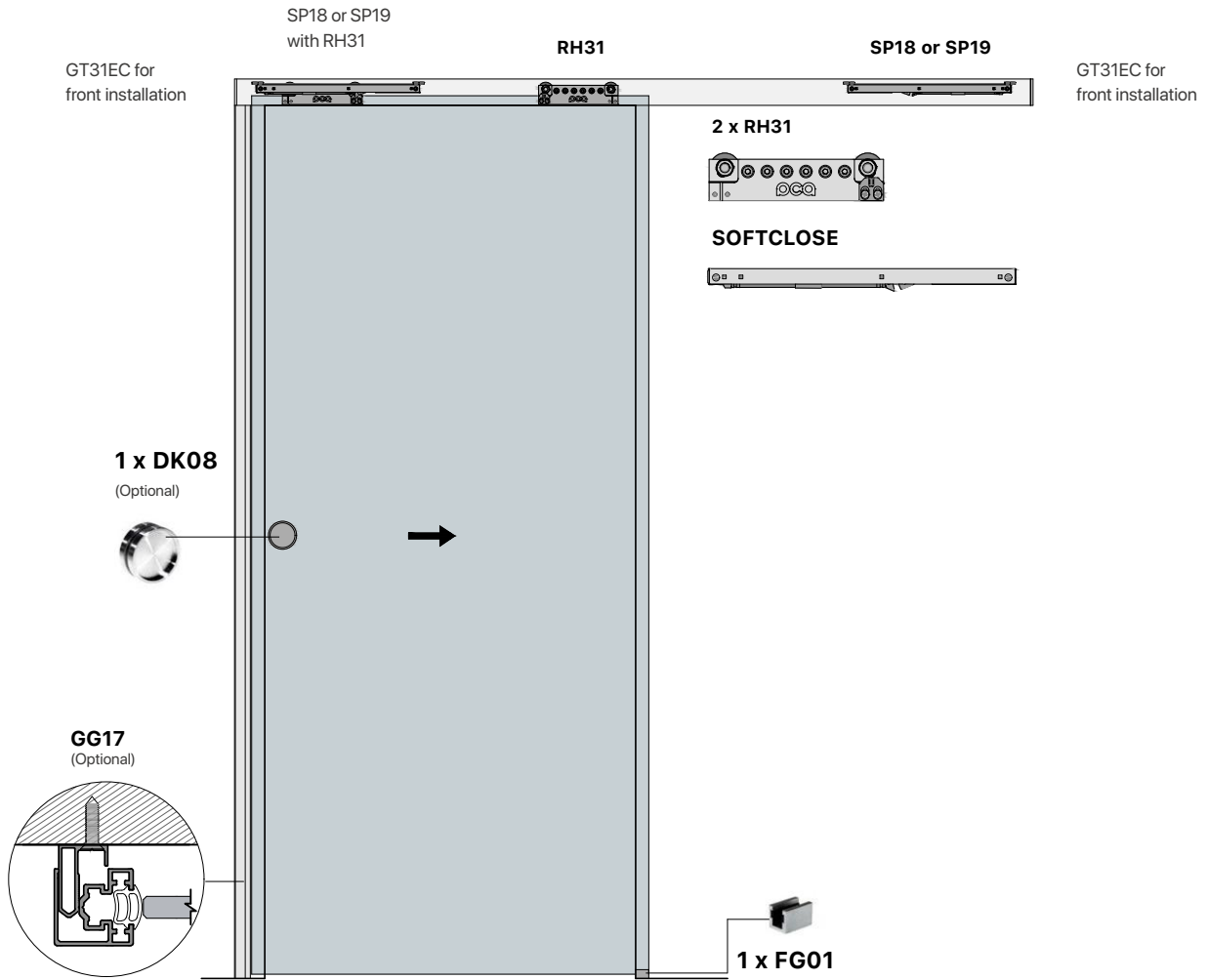

TYOLOGIES

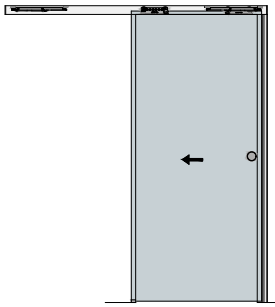

D 1000

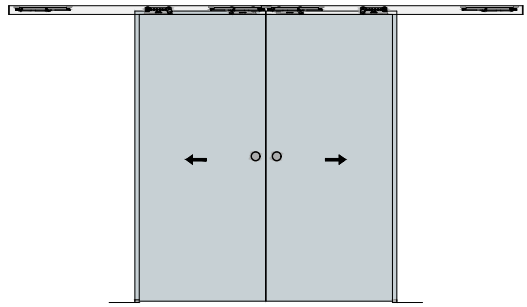

D 1002

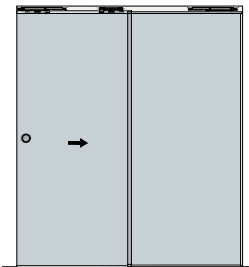

D 3000

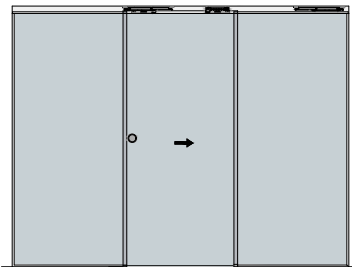

D 3001

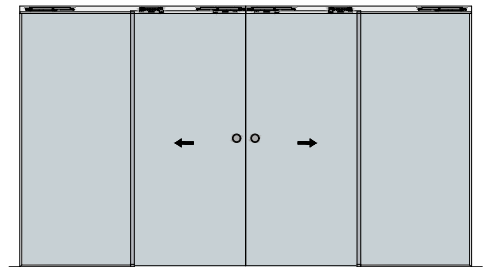

D 3002

SLIDING DOORS

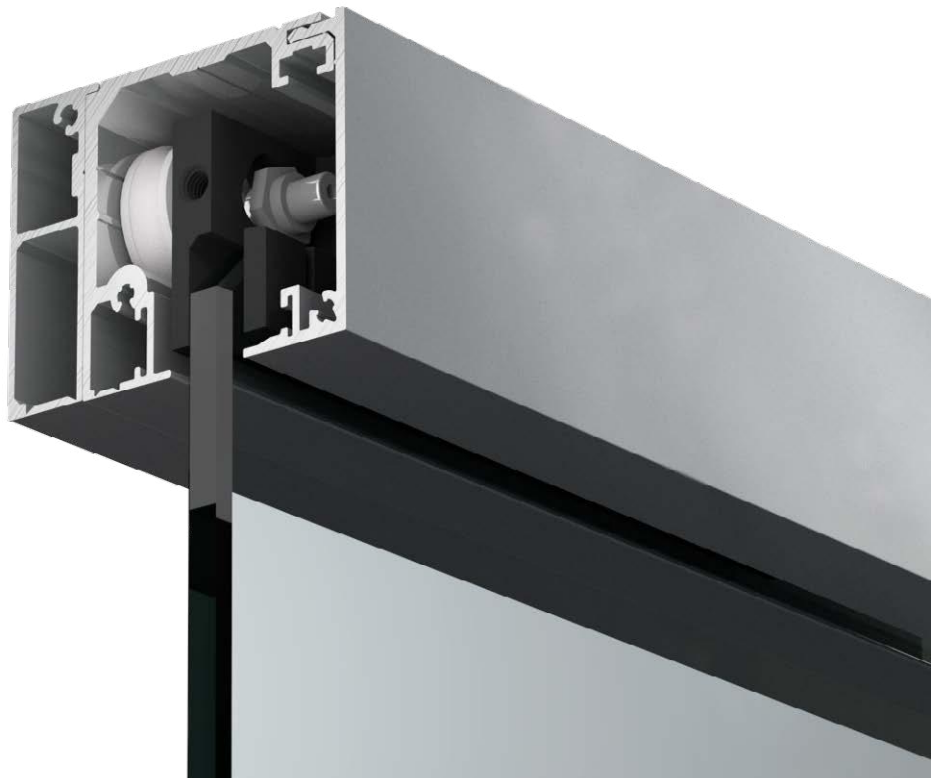



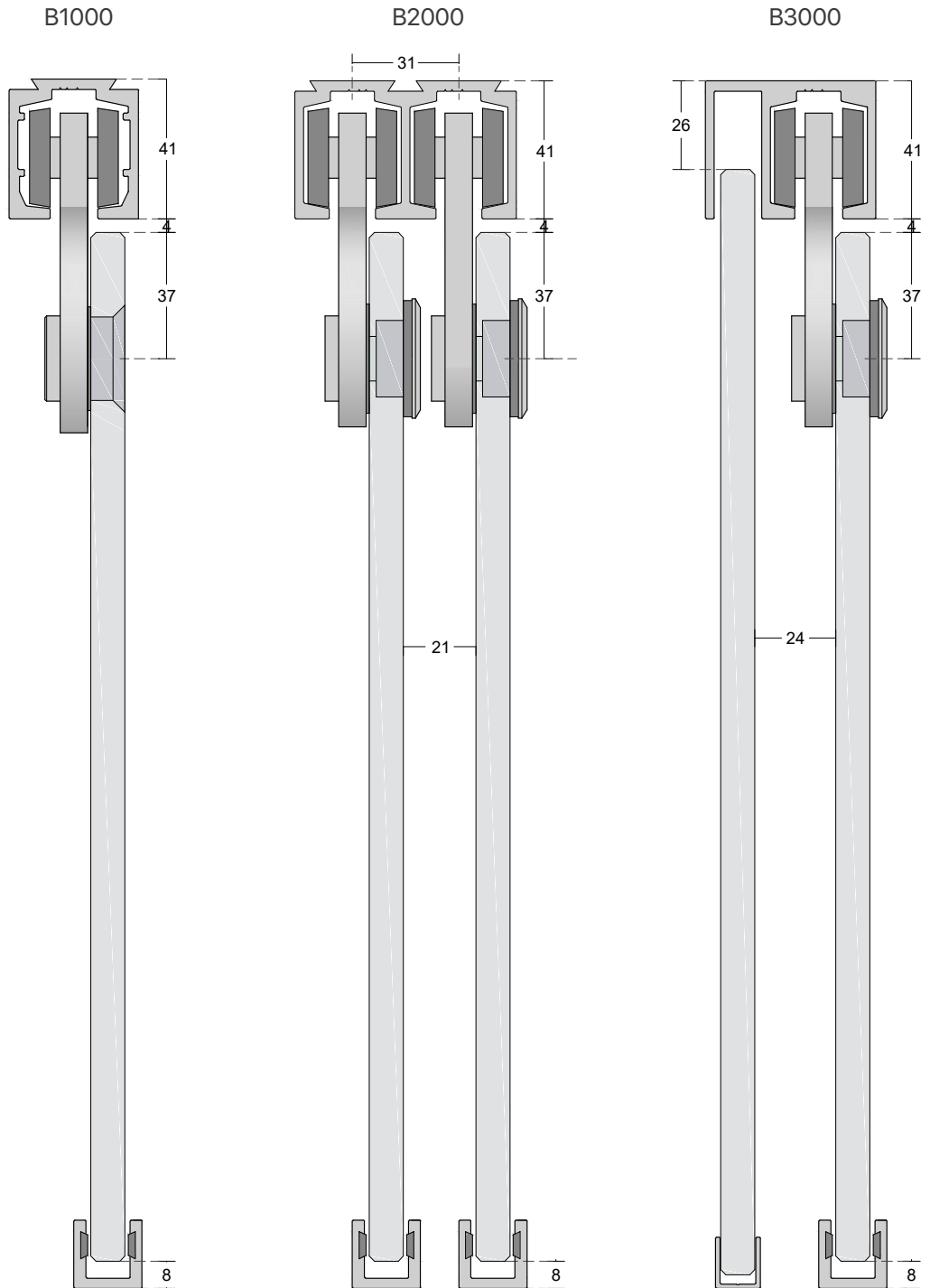

SPECIFICATIONS

GLASS THICKNESS : 10 mm

MAX. LOAD : 80kg

MATERIAL : Aluminium & Stainless Steel

FINISH : Satin & Natural Anodize

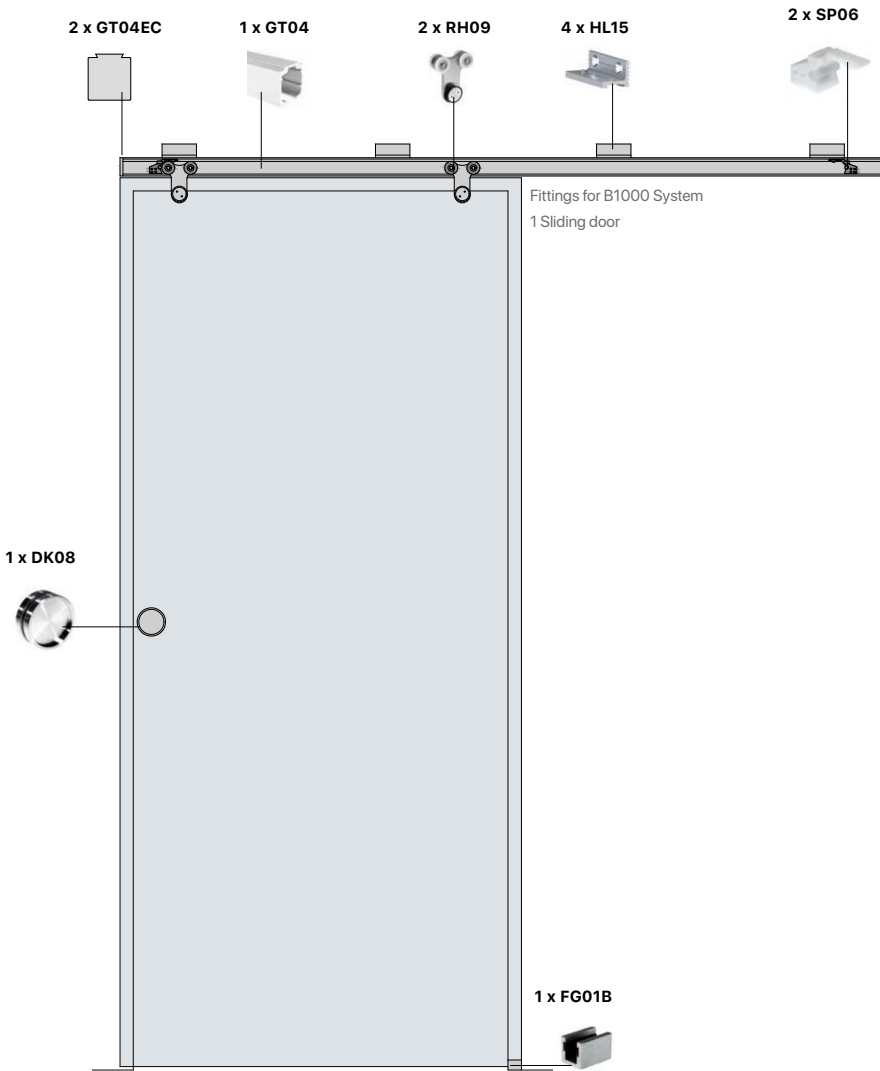

Skylight installation

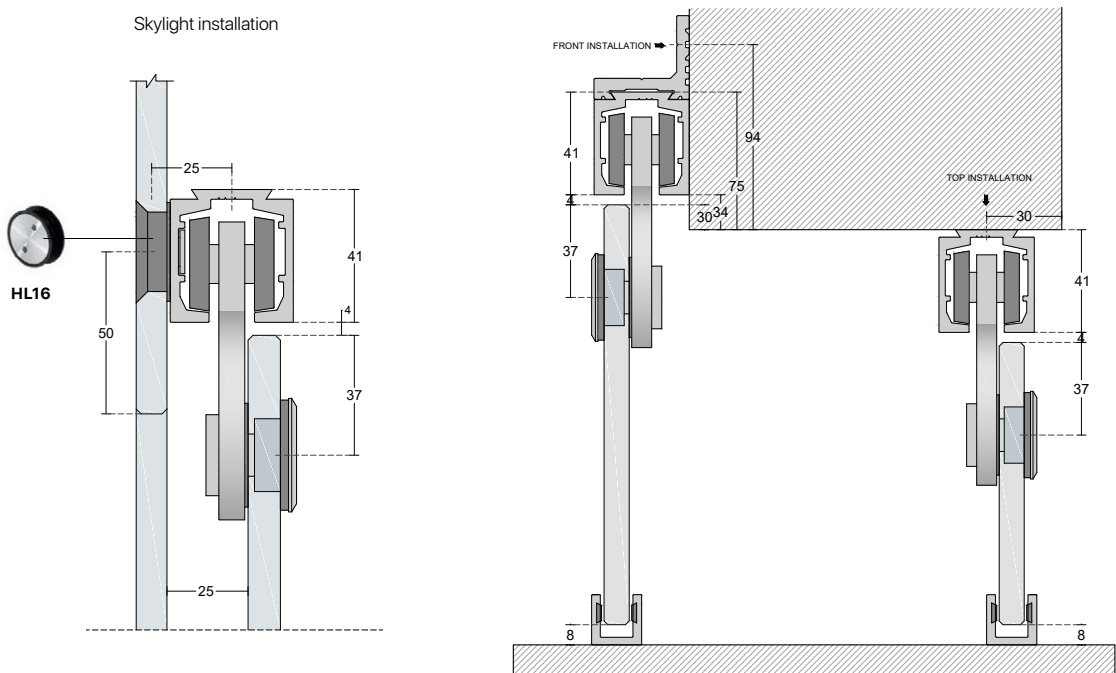

TYPOLOGIES

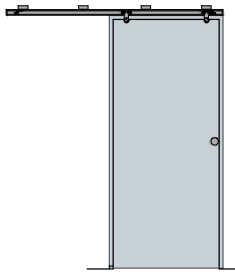

B 1000

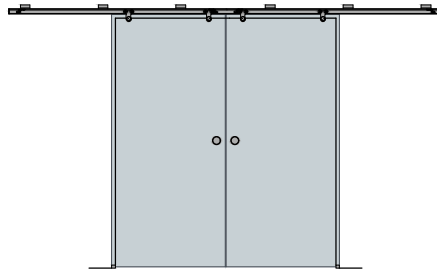

B 1002

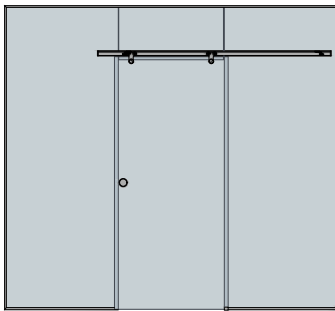

B 1004

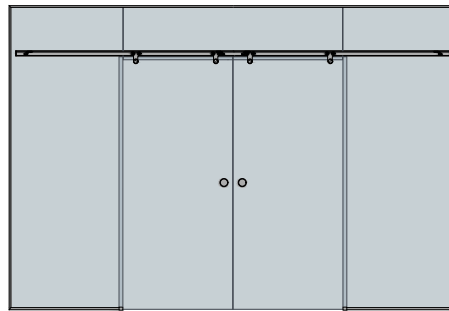

B 1005

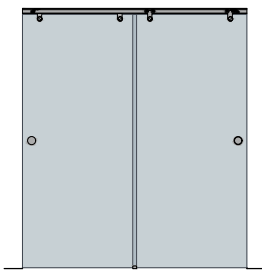

B 2000

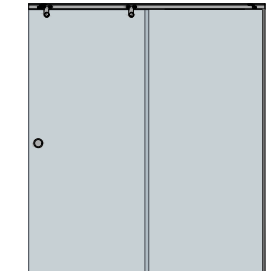

B 3000

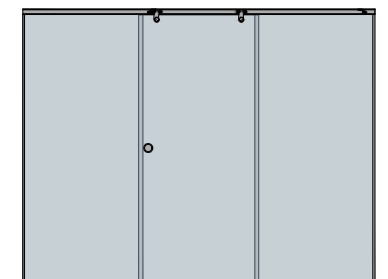

B 3001

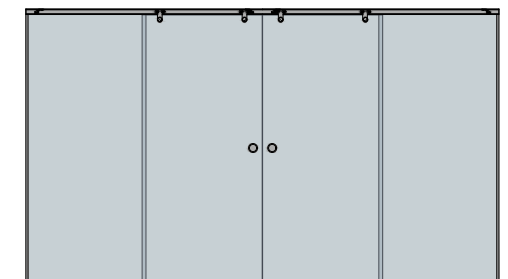

B 3002



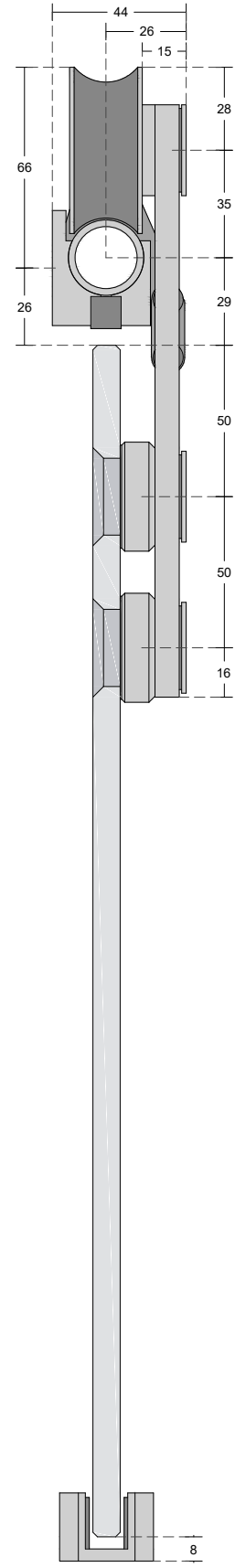

SPECIFICATIONS

- GLASS THICKNESS : 10-12 mm
- MAX. LOAD : 80kg
- MATERIAL : Stainless Steel
- FINISH : Satin

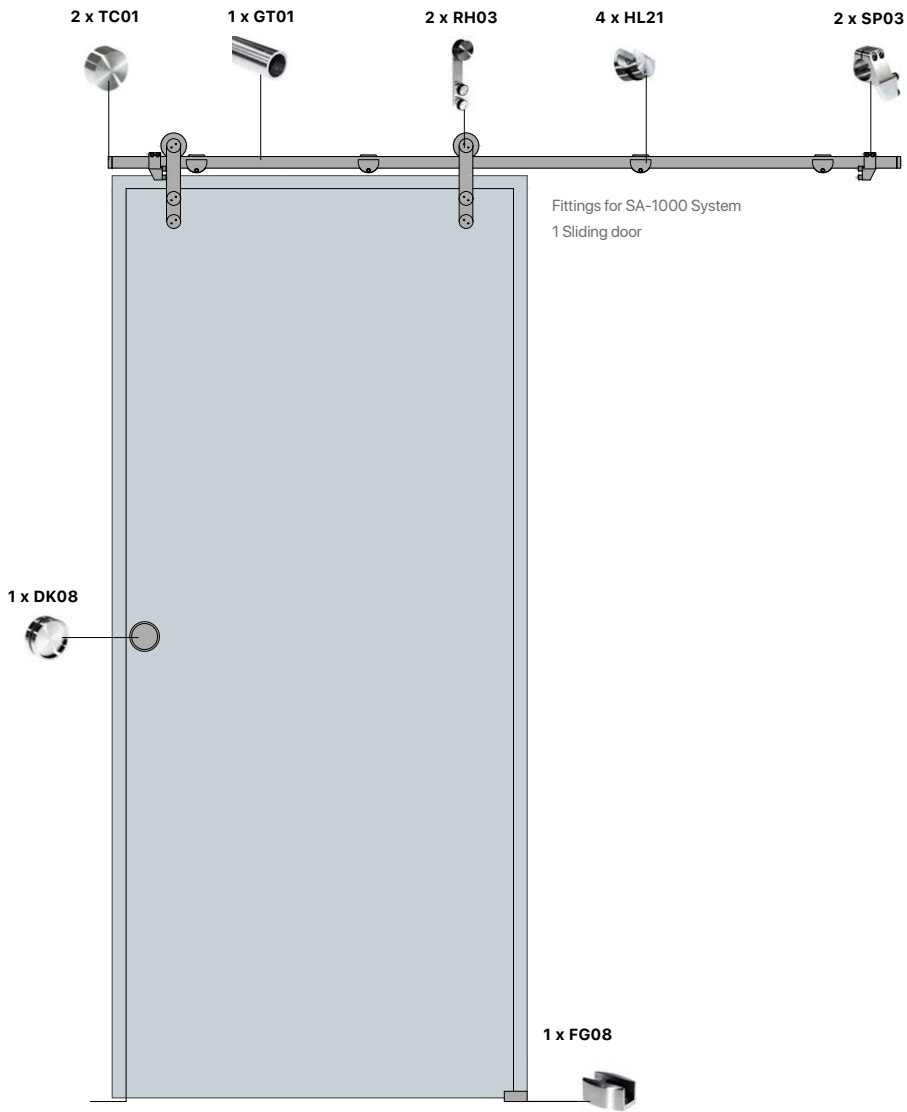

Skylight installation

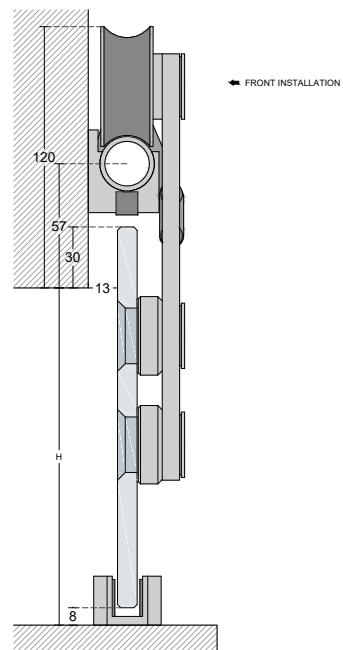
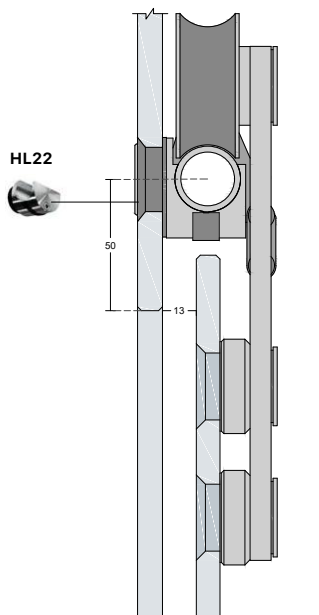

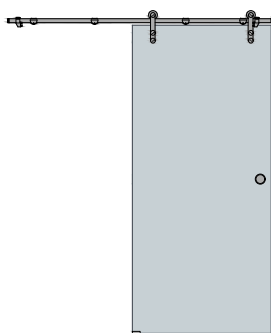

SA 1000

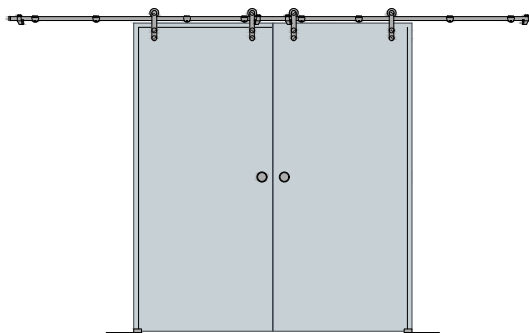

SA 1002

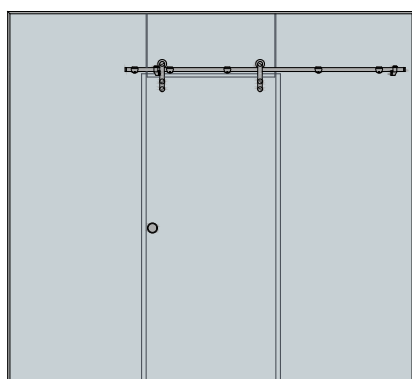

SA 1004



SA 1005





TELESCOPIC SYNCHRONIZED SLIDING DOOR

V1000

SLIDING DOORS



YouTube

SPECIFICATIONS

GLASS THICKNESS : 10 mm

MAX. LOAD : 80kg

FUNCTION : TELESCOPIC SYNCHRONIZATION

MATERIAL : Aluminium

FINISH : Satin & Natural Anodize



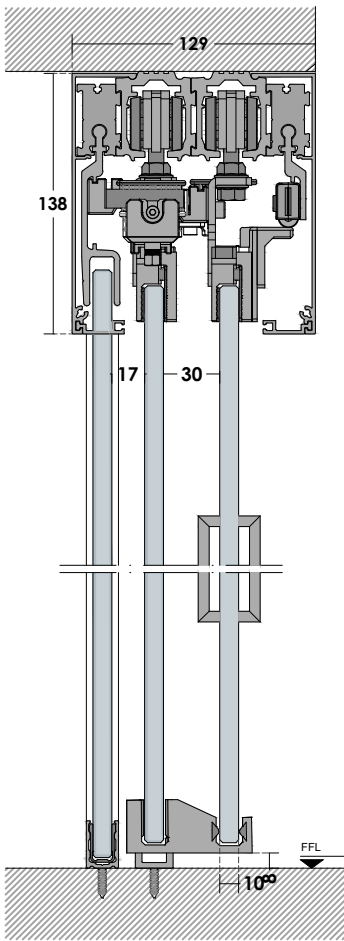

V 1002 - MODEL

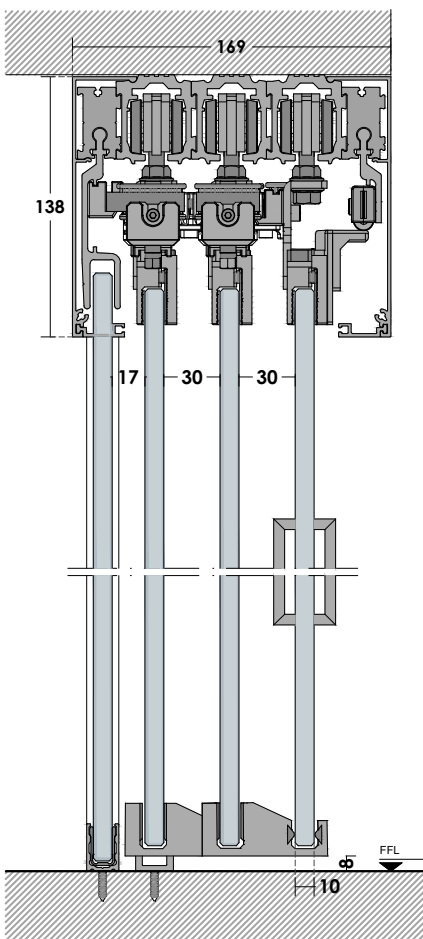
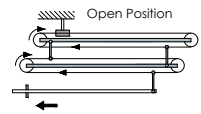
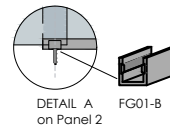
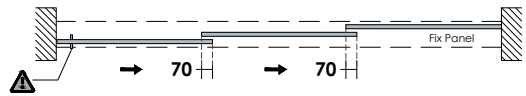
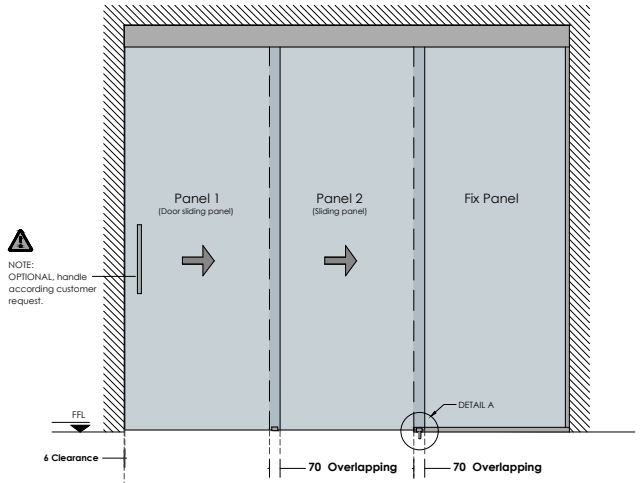

V 1003 - MODEL

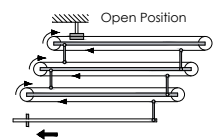
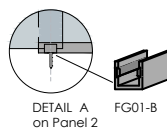
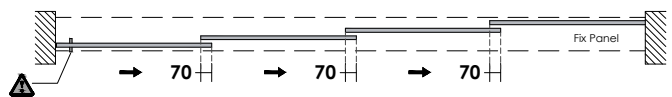
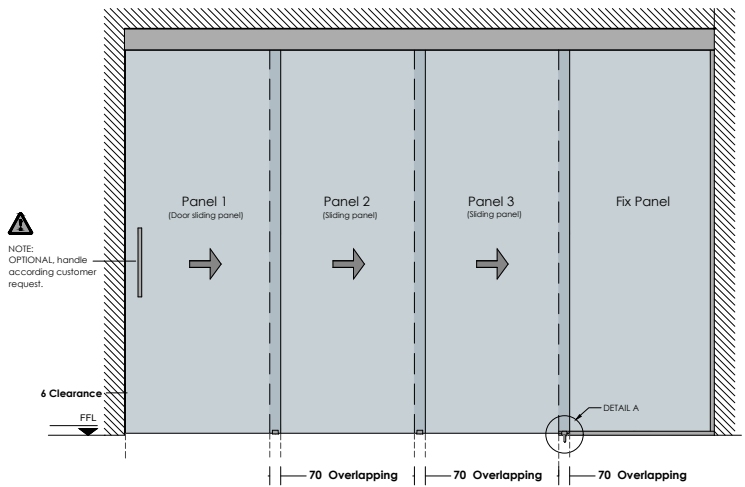

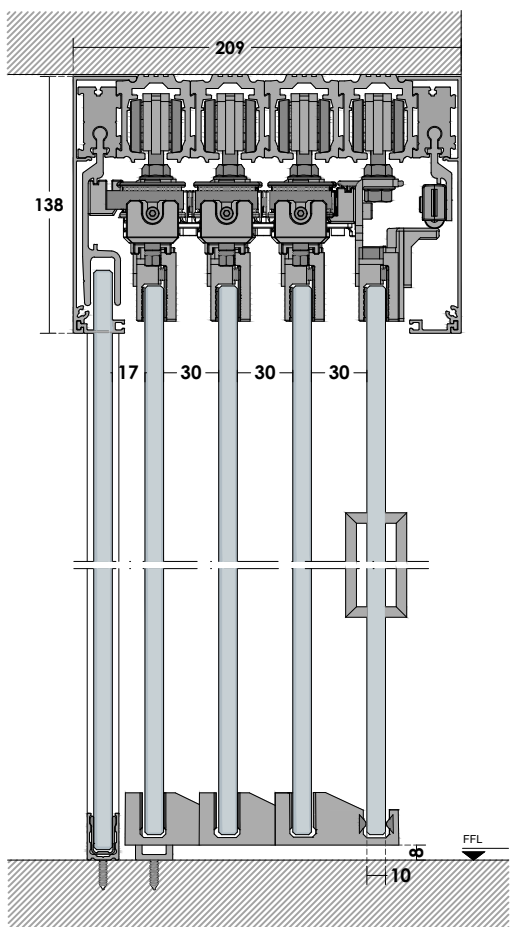

V 1004 - MODEL

NOTE:
OPTIONAL handle
according customer
request.

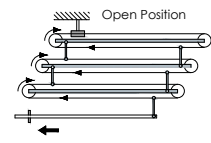
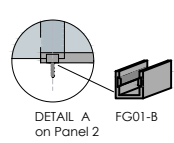
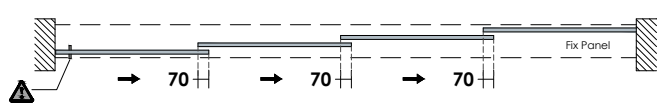
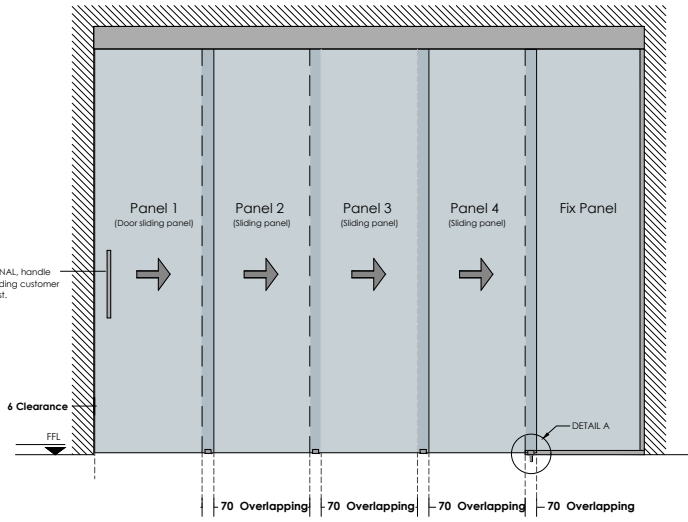

SPECIFICATIONS

GLASS THICKNESS : 6,8 mm

MAX. LOAD : 80kg

FUNCTION : SOFTCLOSE

MATERIAL : Aluminium

FINISH : Satin & Natural Anodize & Black Anodize



SOFTCLOSE SLIDING DOOR SERIES | **V2000**



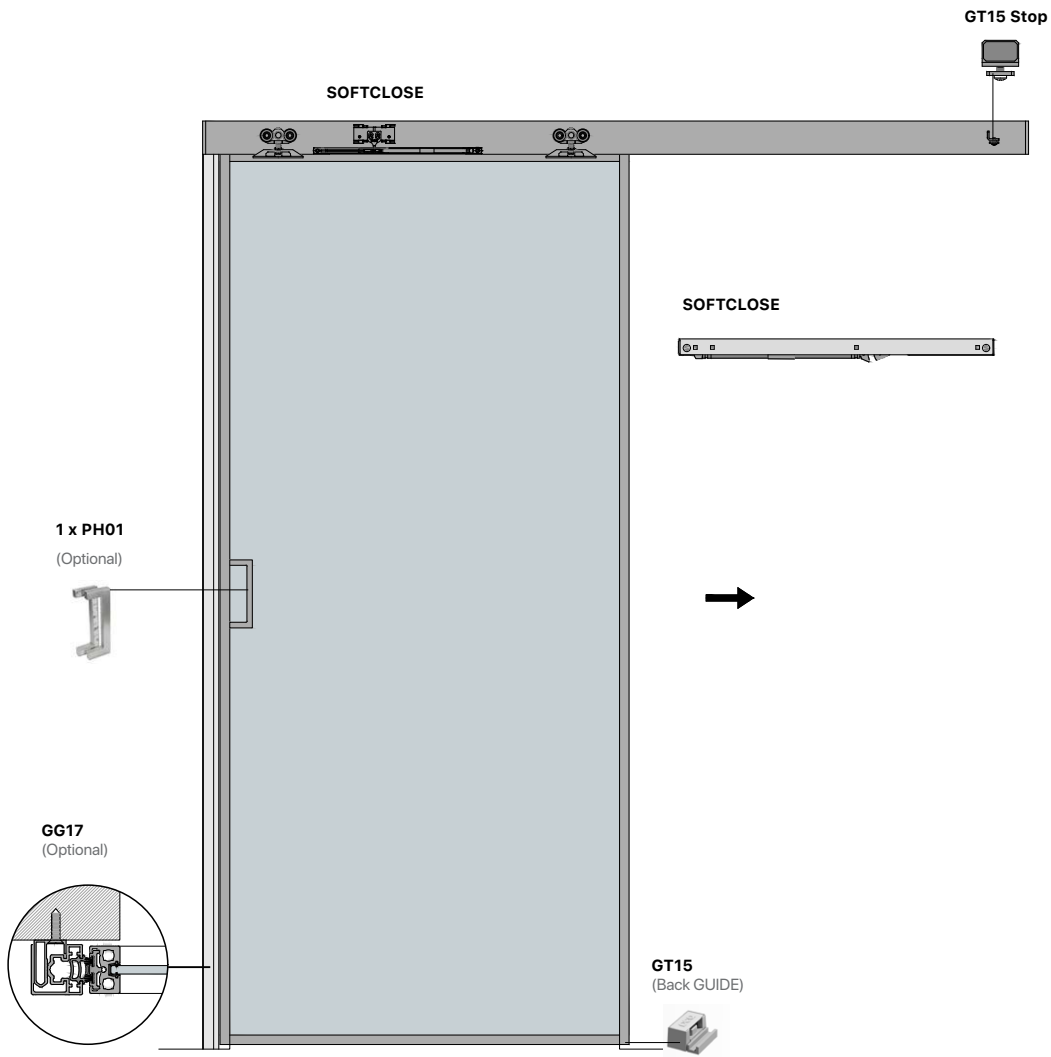

- PANEL < 637mm → NO SOFTCLOSE
- 637mm ≥ PANEL > 1012mm → 1 SOFTCLOSE
- 1012mm ≥ PANEL ≥ 1250mm → 2 SOFTCLOSE

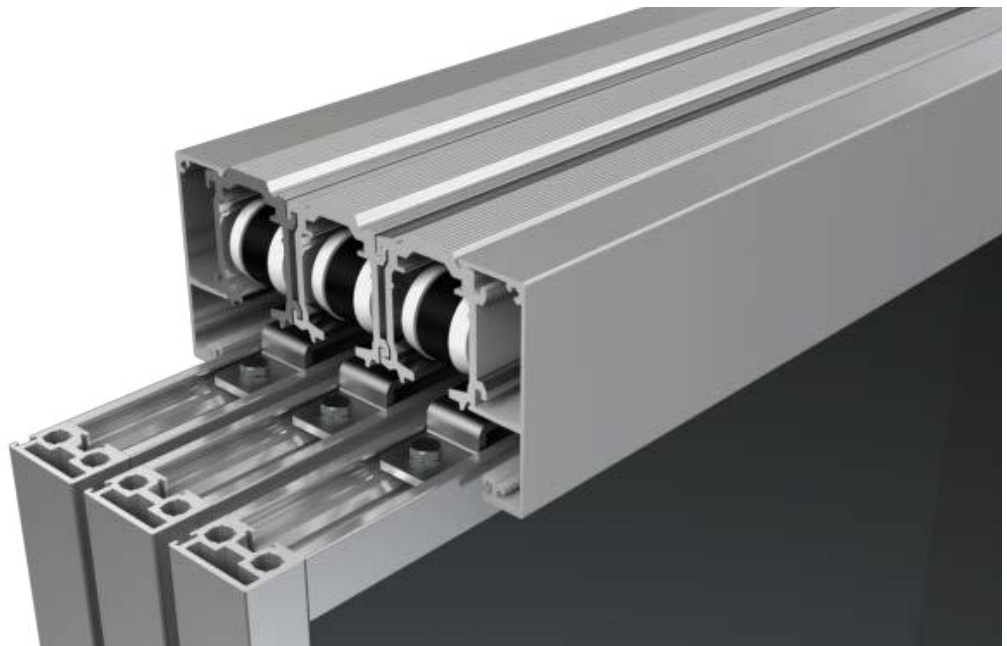

TYOLOGIES

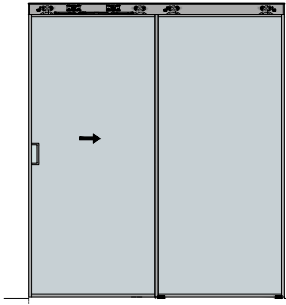

V 2001
Ceiling Installation

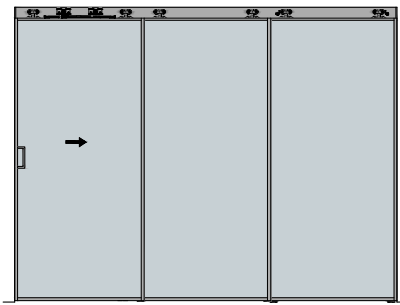

V 2002
Ceiling Installation

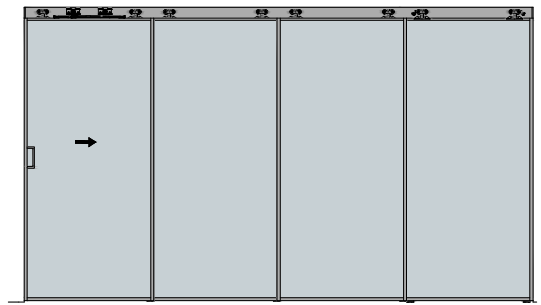

V 2003
Ceiling Installation

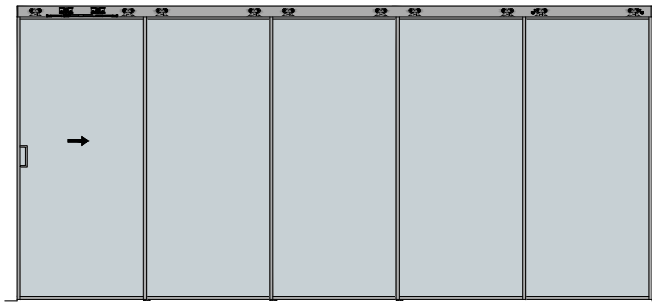

V 2004
Ceiling Installation

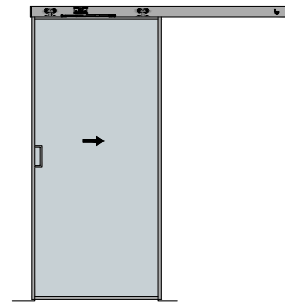

V 2005
Front Installation

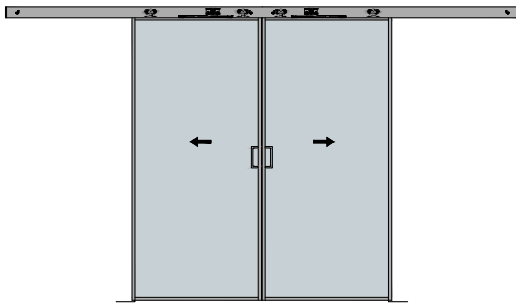

V 2006
Front Installation

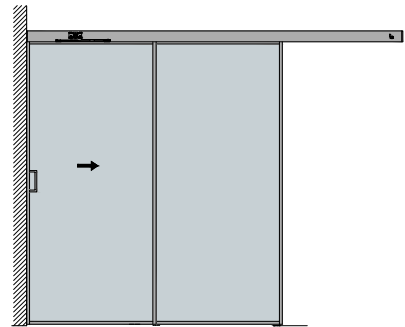

V 2007
Front Installation

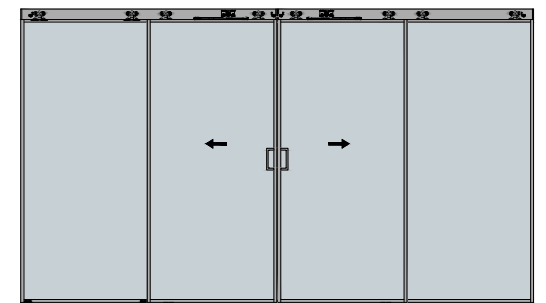

V 2008
Ceiling Installation

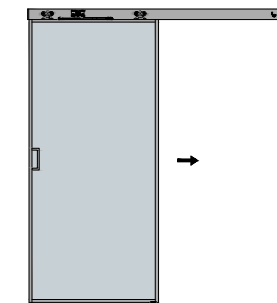

V 2009
Ceiling Installation

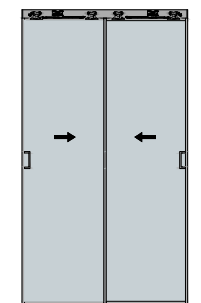

V 2010
Ceiling Installation

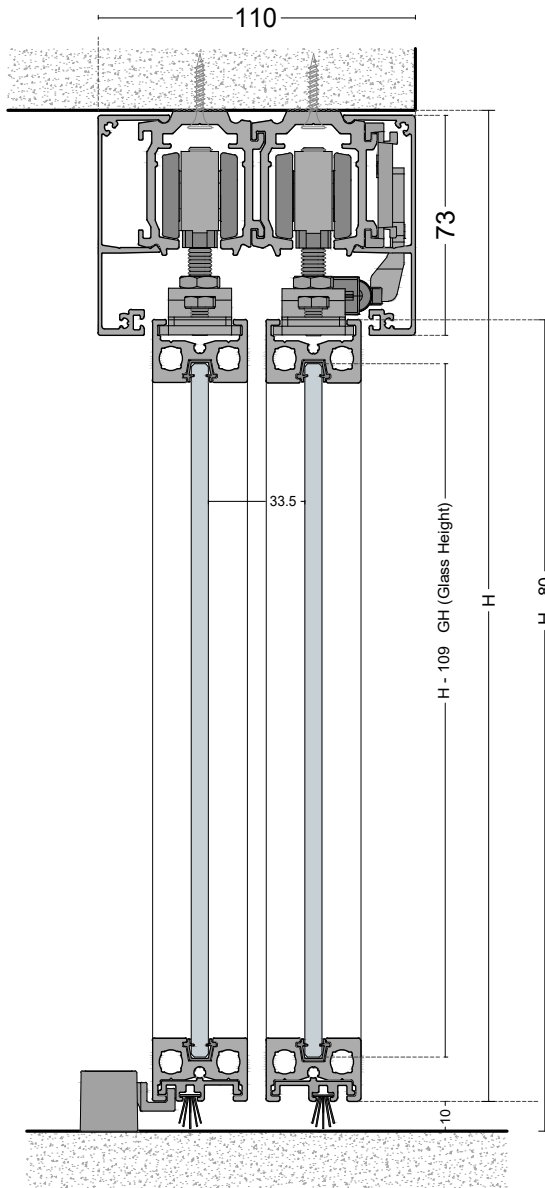

V 2001

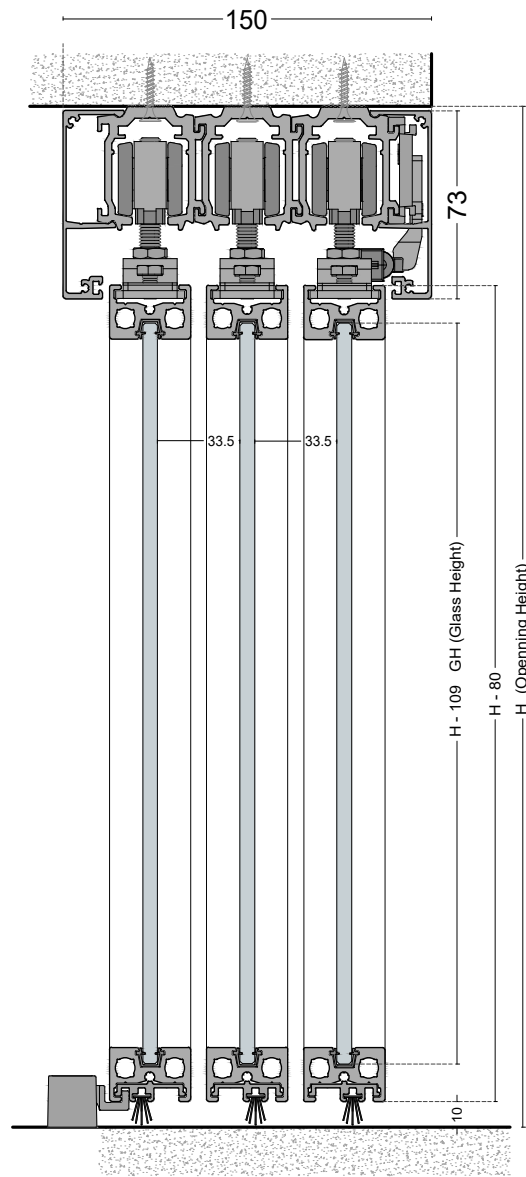

V 2002

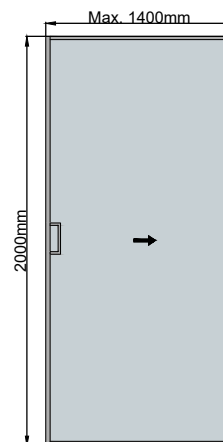
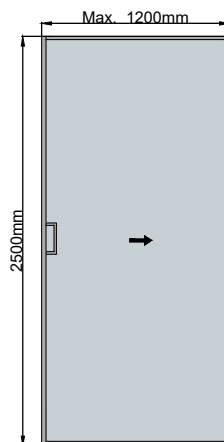
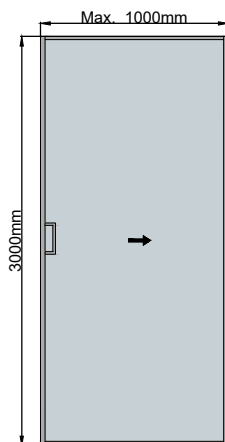

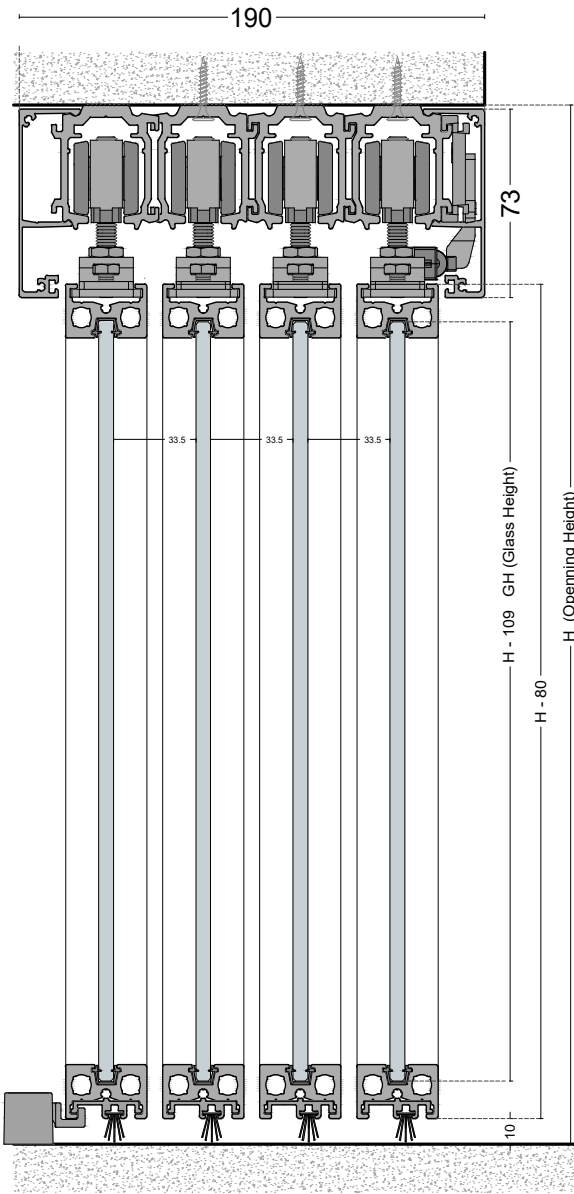

V 2003

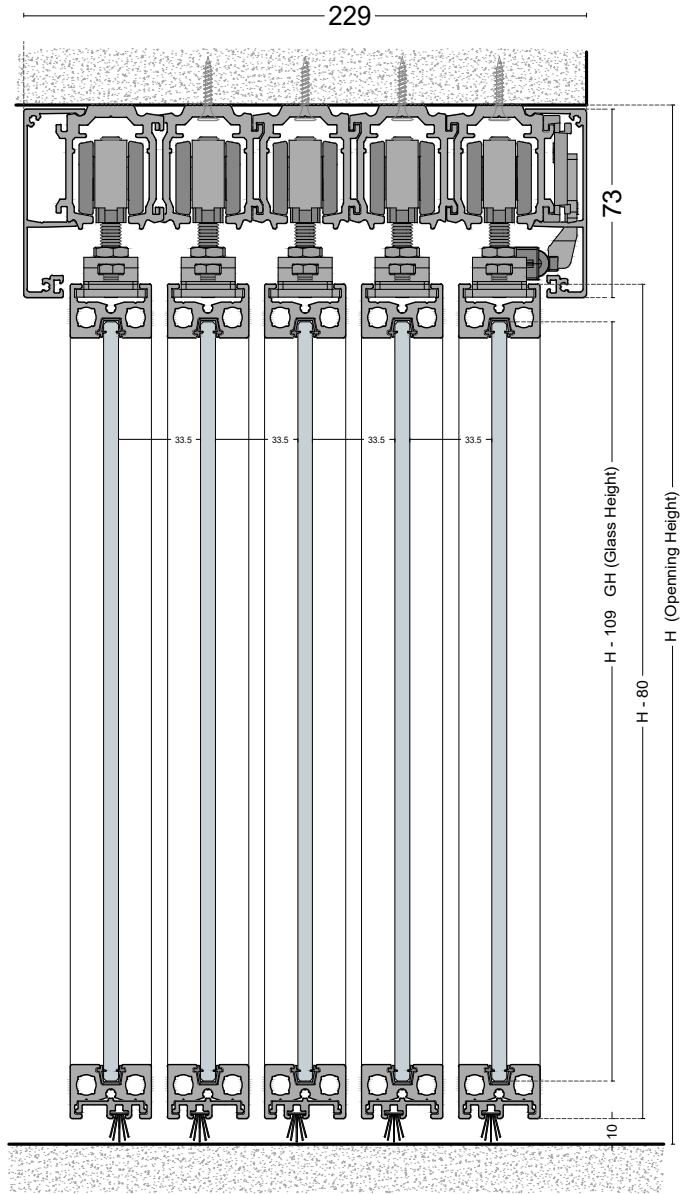

V 2004

SLIDING DOORS

Material: Aluminium
 Finish: Satin, Natural Anodize, Black Anodize
 Glass Thickness: 6mm, 8mm
 Maximum Dimensions: 1000x3000, 1200x2500, 1400x2000

PRODUCT LIST



PCA-GT31
Guide Track Profile
 580 cm | Length
 Aluminium | Material
 Natural Anodize, Satin, Black | Finish

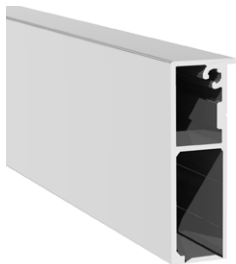
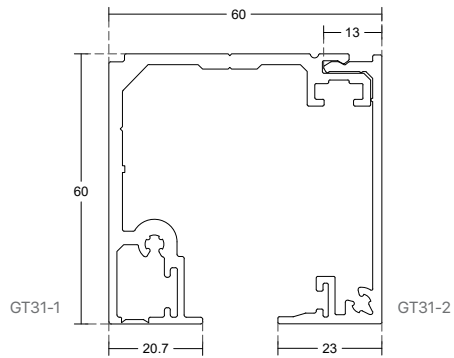

PCA-GT31-3
Guide Track Profile
 580 cm | Length
 Aluminium | Material
 Natural Anodize, Satin, Black | Finish

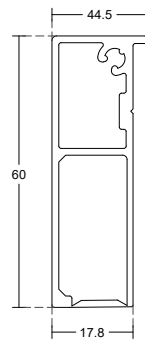

PCA-RH31
Roller Hanger
 40kg/piece | Max. Weight
 10mm | Glass Thickness
 Stainless Steel | Material
 Black | Finish

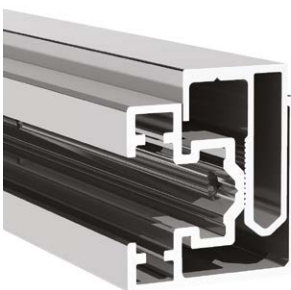
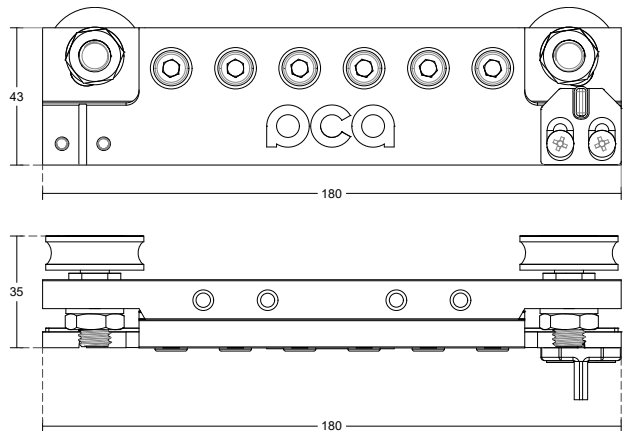

PCA-GG17
Guide Track Profile
 580 cm | Length
 Aluminium | Material
 Natural Anodize, Satin, Black | Finish

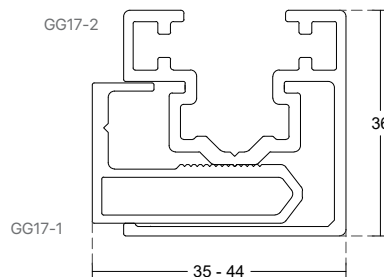

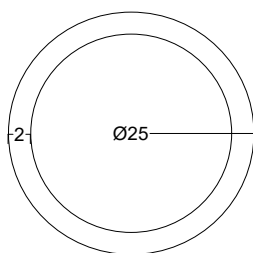

PCA-GT01
Guide Track Profile
 600cm | Length
 Stainless Steel 304 | Material
 Satin | Finish

Glass Cut

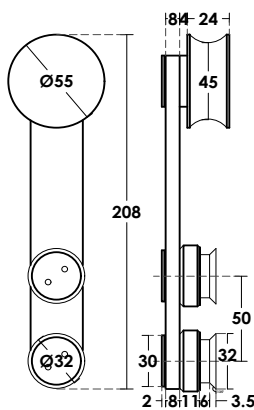
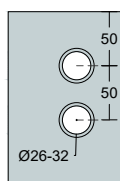

PCA-RH03
Round Track Roller Hanger
 80kg | Max. Weight
 10mm | Glass Thickness
 Stainless Steel | Material
 Satin | Finish

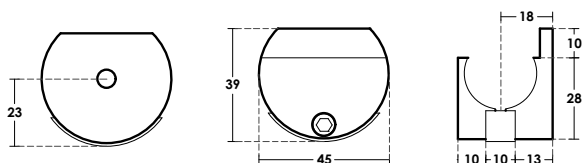

PCA-HL21
Round Track-Wall Holder
 40kg | Max. Weight
 Stainless Steel | Material
 Satin | Finish

Glass Cut

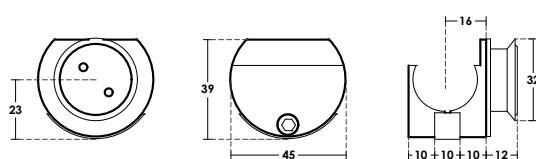

PCA-HL22
Round Track-Glass Holder
 40kg | Max. Weight
 10mm | Glass Thickness
 Stainless Steel | Material
 Satin | Finish

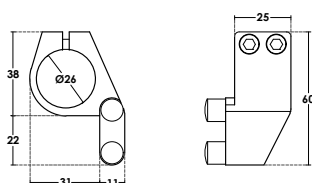

PCA-SP03L | SPO3R
Round Track Stop SET
 Stainless Steel | Material
 Satin | Finish



**PCA-RH08
Roller Hanger**
40kg | Max. Weight
10mm | Glass Thickness
Stainless Steel | Material
Satin | Finish

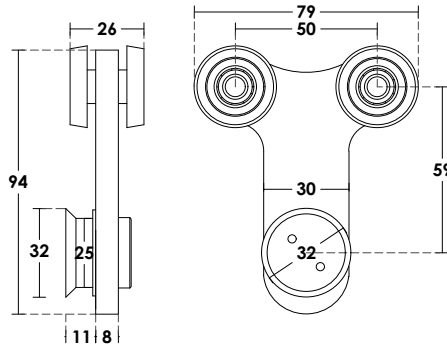

Glass Cut

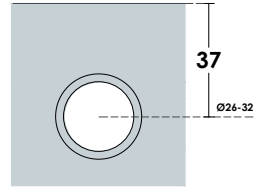

**PCA-RH09
Roller Hanger**
40kg | Max. Weight
10mm | Glass Thickness
Stainless Steel | Material
Satin | Finish

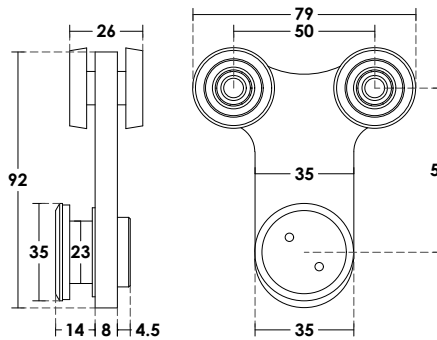

Glass Cut

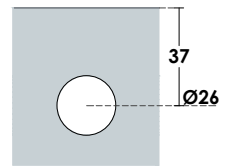

**PCA-SP06
Stop**
PVC | Material
White | Finish

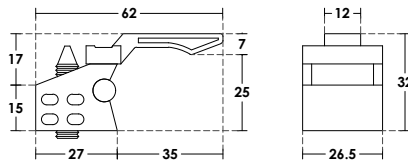

**PCA-HL16
Track-Glass Holder**
20kg | Max. Weight
10mm | Glass Thickness
Stainless Steel | Material
Satin | Finish

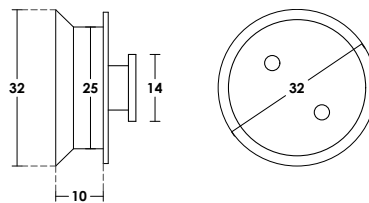

Glass Cut

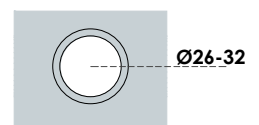

**PCA-FG08
Floor Guide**
8,10,12mm | Glass Thickness
Stainless Steel | Material
Satin | Finish

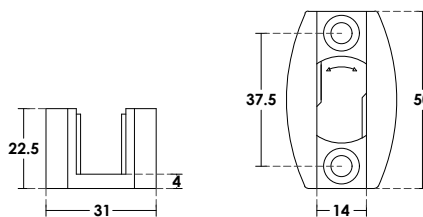

**PCA-HL18
Track Holder**
PVC | Material

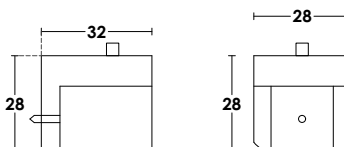

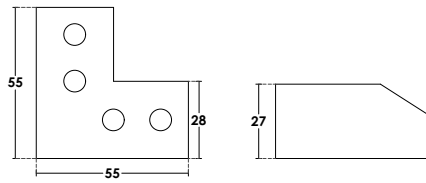

PCA-HL17
Track Holder
PVC | Material

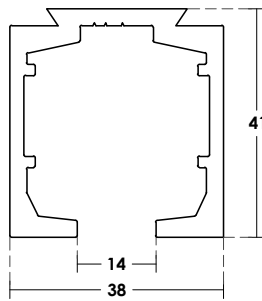

PCA-GT04
Guide Track Profile
580 cm | Length
1,248kg | Weight/meter
Aluminium | Material
Natural Anodize, Satin | Finish

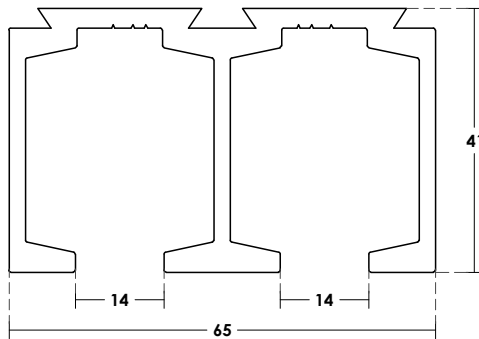

PCA-GT05
Guide Track Profile
580 cm | Length
1,802kg | Weight/meter
Aluminium | Material
Natural Anodize, Satin | Finish

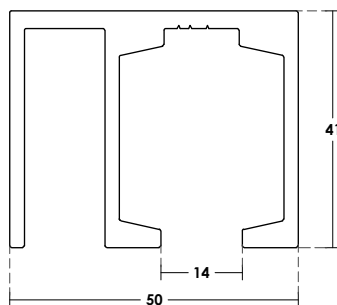

PCA-GT06
Guide Track Profile
580 cm | Length
1,505kg | Weight/meter
Aluminium | Material
Natural Anodize, Satin | Finish

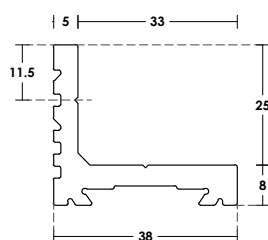

PCA-HL15
Guide Track Fixing Profile
120 mm | Length
0,915kg | Weight/meter
Aluminium | Material
Satin | Finish

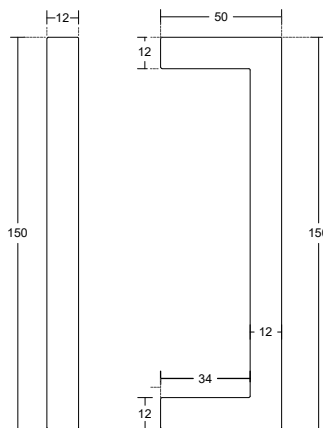

PCA-PH01
Door Handle

8,10mm | Glass Thickness
Aluminium | Material
Natural Anodize, Satin, Black | Finish



Including Very Hi-Bond Adhesive Tape

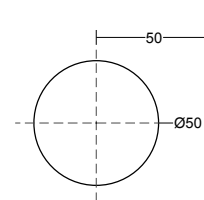
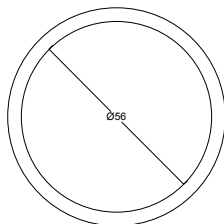

Glass Cut

PCA-DK08
Sliding Door Knob

8-12mm | Glass Thickness
Aluminium, Stainless Steel 304 | Material
Satin, Black | Finish

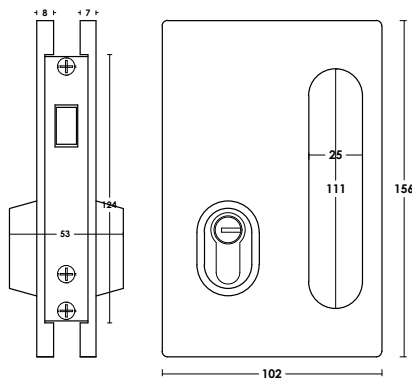

Glass Cut

PCA-DL09
Sliding Door Lock

8,10mm | Glass Thickness
Stainless Steel | Material
Satin | Finish

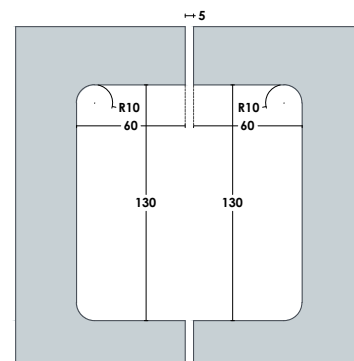
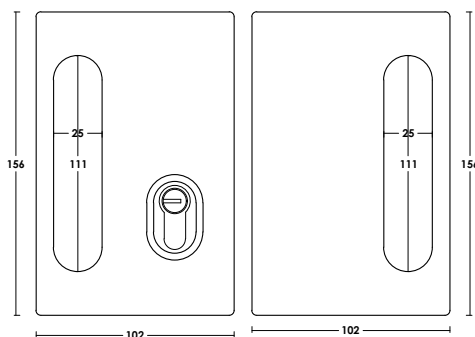

Glass Cut

PCA-DL09B
Sliding Door Lock

8,10mm | Glass Thickness
Stainless Steel | Material
Satin | Finish



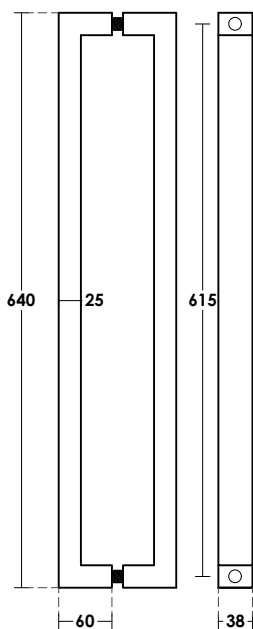
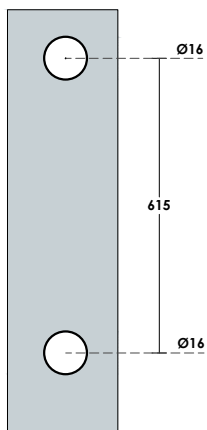

PCA-HD13
Door Handle 38x25 mm
 10 mm | Glass Thickness
 Stainless Steel 304 | Material
 Satin | Finish

AVAILABLE DIMENSIONS

	HEIGHT	C-C-D	C-C-W
HD01A	60cm	36cm	
HD01B/HD01BW	80cm	50cm	62,5cm
HD01C/HD01CW	100cm	60cm	82,5cm
HD01D/HD01DW	120cm	80cm	90cm
HD01E/HD01EW	150cm	100cm	102,5cm
HD01F/HD01FW	180cm	120cm	130cm
HD01G	200cm	140cm	
HD01H	50cm	23cm	

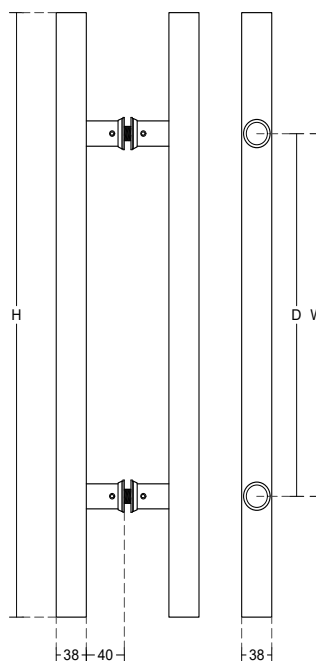
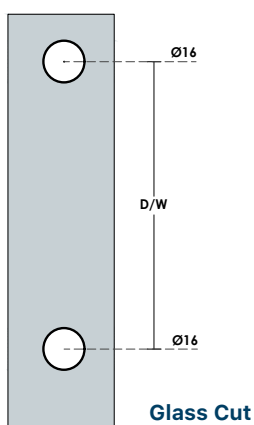

PCA-HD01
Door Handle Ø38mm
 10 mm | Glass Thickness
 Stainless Steel 304 | Material
 Satin | Finish

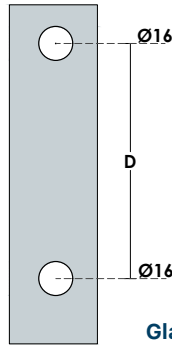
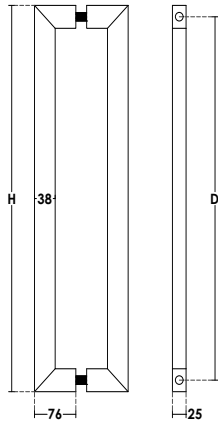

Glass Cut

AVAILABLE DIMENSIONS

	HEIGHT	C-C-D
HD03A	64cm	60cm
HD03B	104cm	100cm
HD03C	144cm	140cm
HD03D	36cm	32cm

PCA-HD03
Door Handle 25x38 mm
 10 mm | Glass Thickness
 Stainless Steel 304 | Material
 Satin | Finish

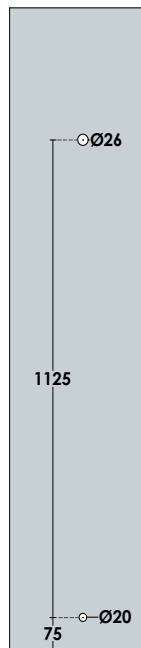
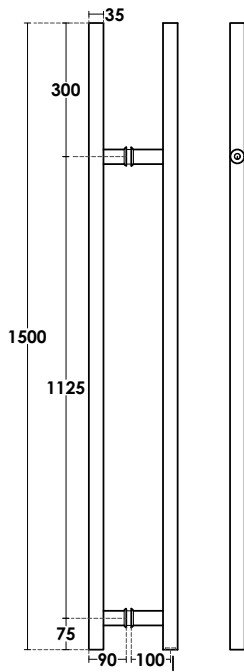

Glass Cut

HD06



HD06A



PCA-HD06
Door Lock - Handle Ø35mm
 10-12 mm | Glass Thickness
 Stainless Steel 304 | Material
 Satin | Finish

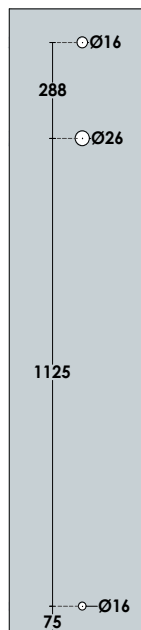
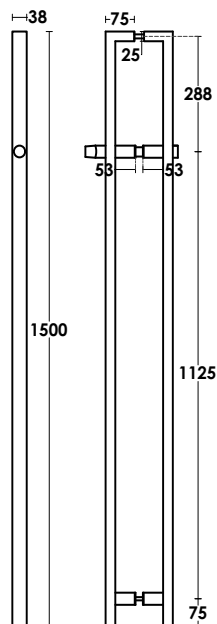

Glass Cut



PCA-HD14
Door Lock - Handle Ø35mm
 10-12 mm | Glass Thickness
 Stainless Steel 304 | Material
 Satin | Finish



FRAME DOORS

A1 | GT10 & GT09 profile



A2 | GT11 profile

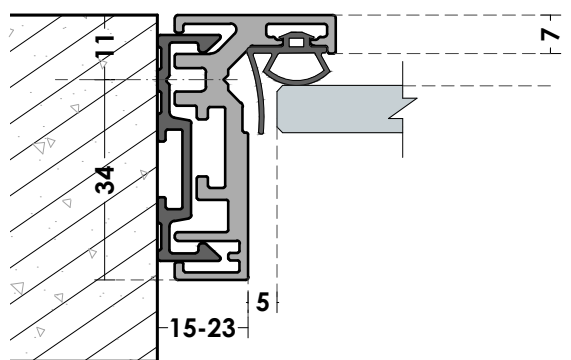
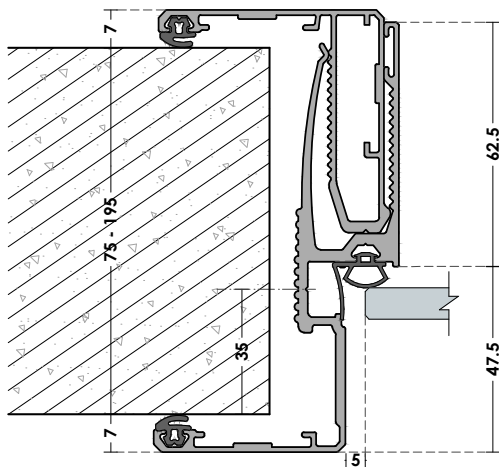

pg. 116

pg. 117

A3 | GT13 profile

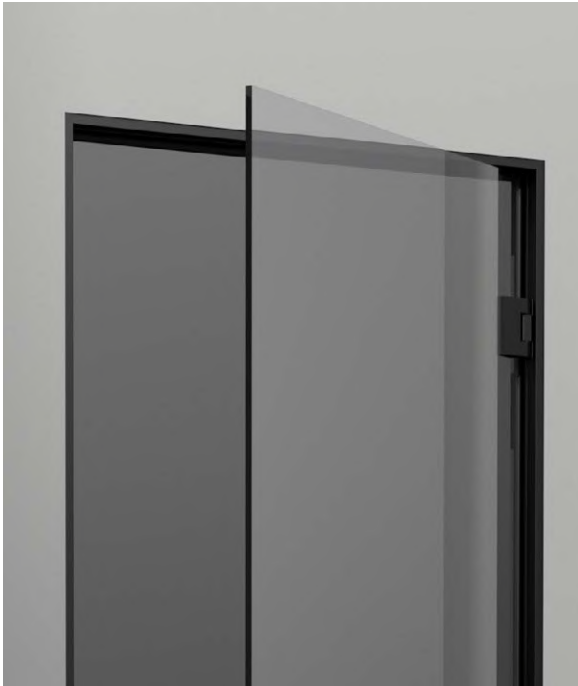

A4 | GT12 profile



DOORS

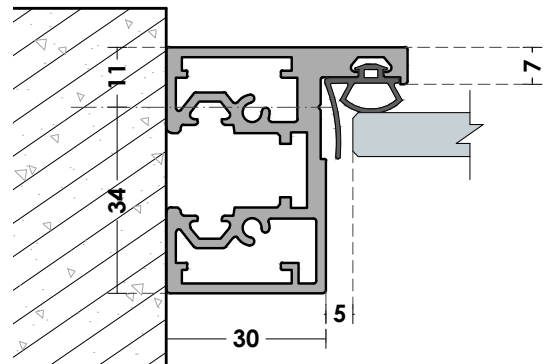
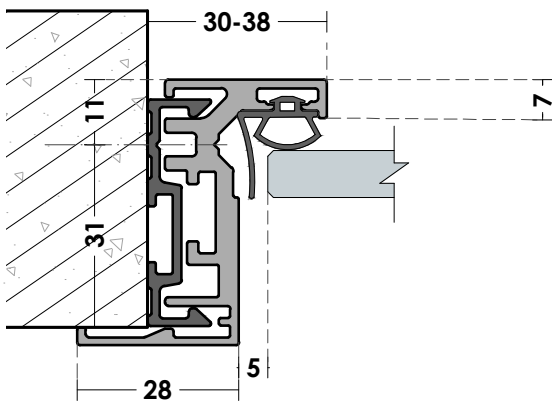

pg. 118

pg. 119

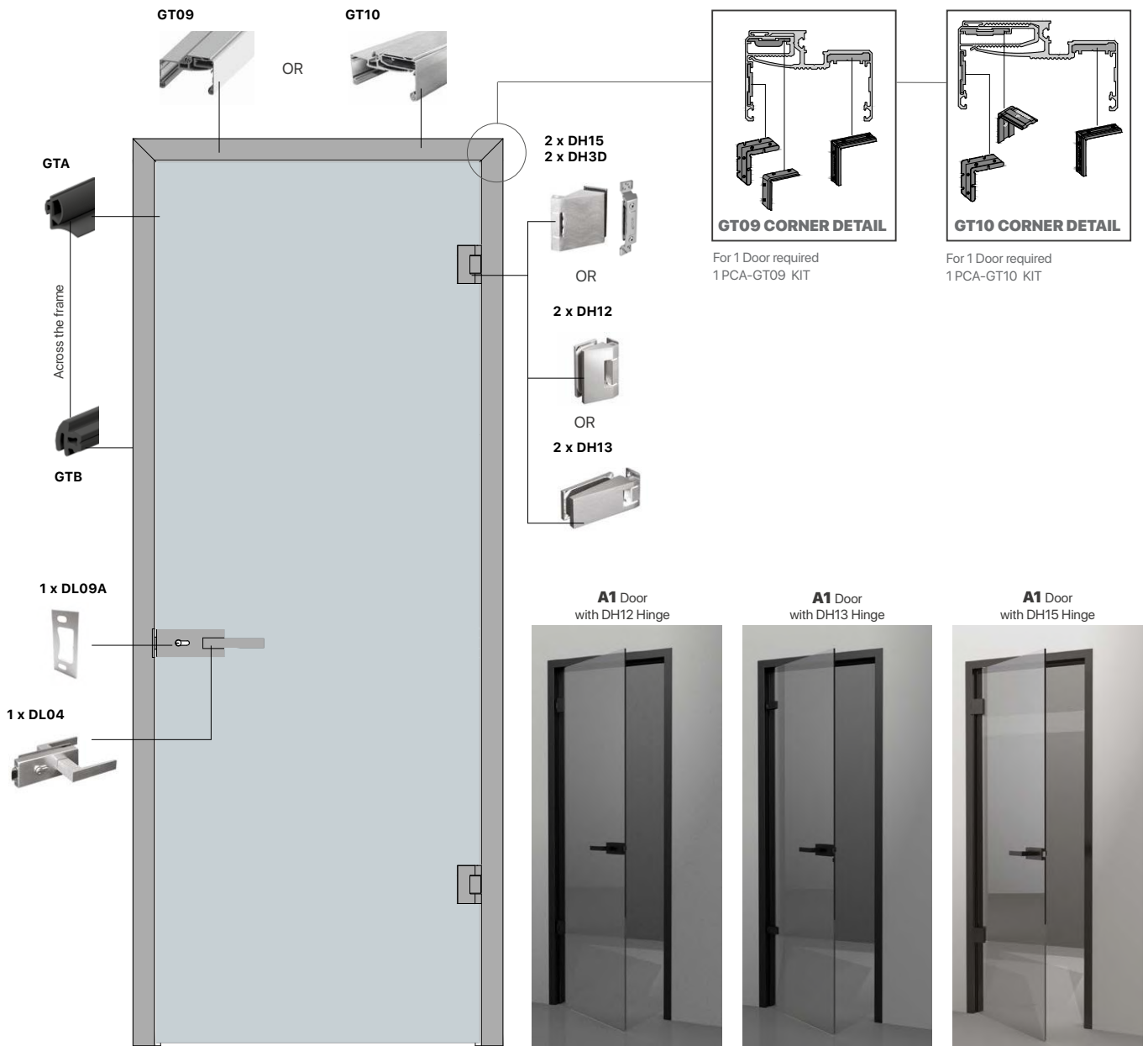

GT09 | GT10 Frame Section Details

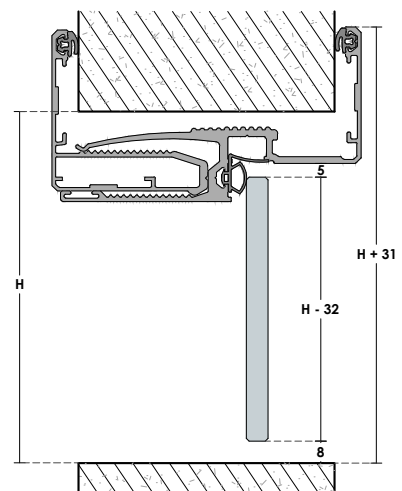
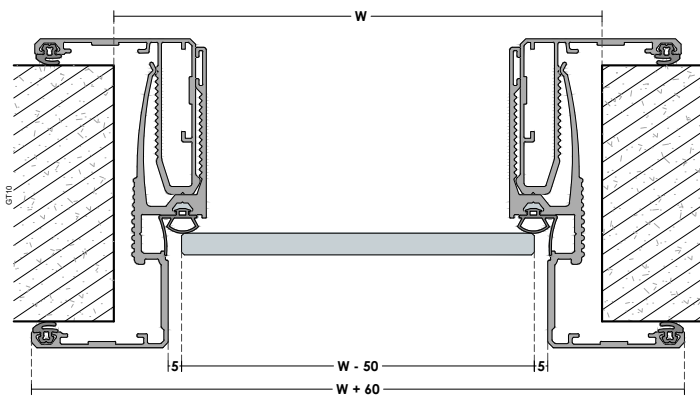

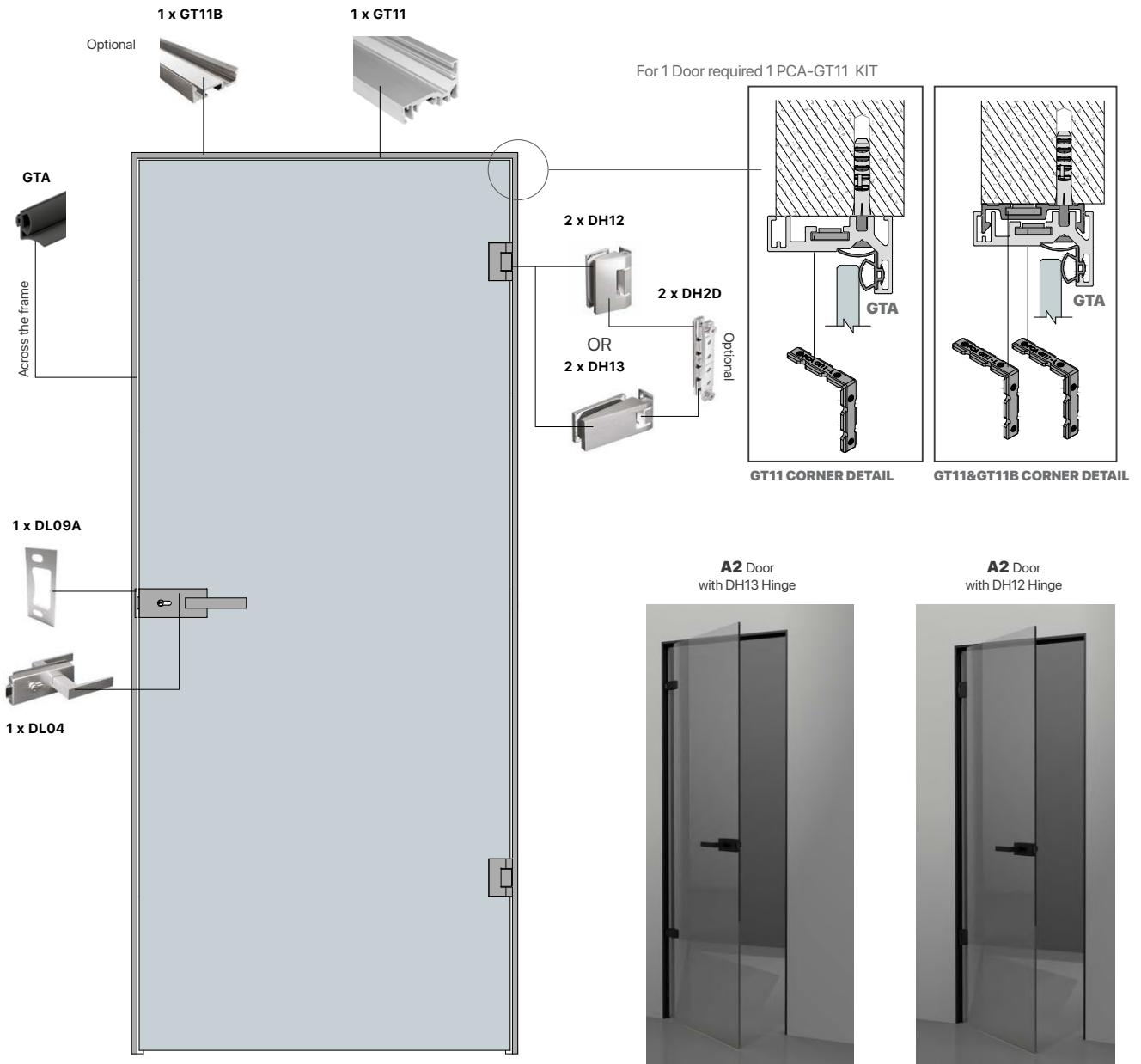

DOORS



GT11 and GT11 with GT11B Frame Section Details

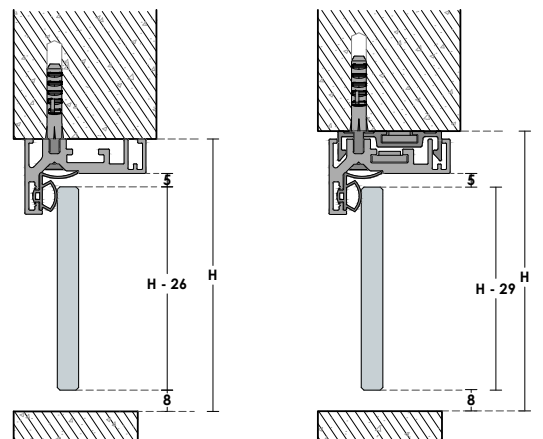
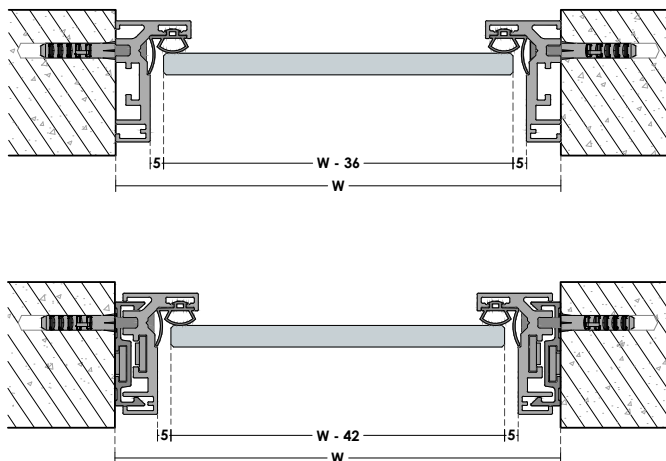

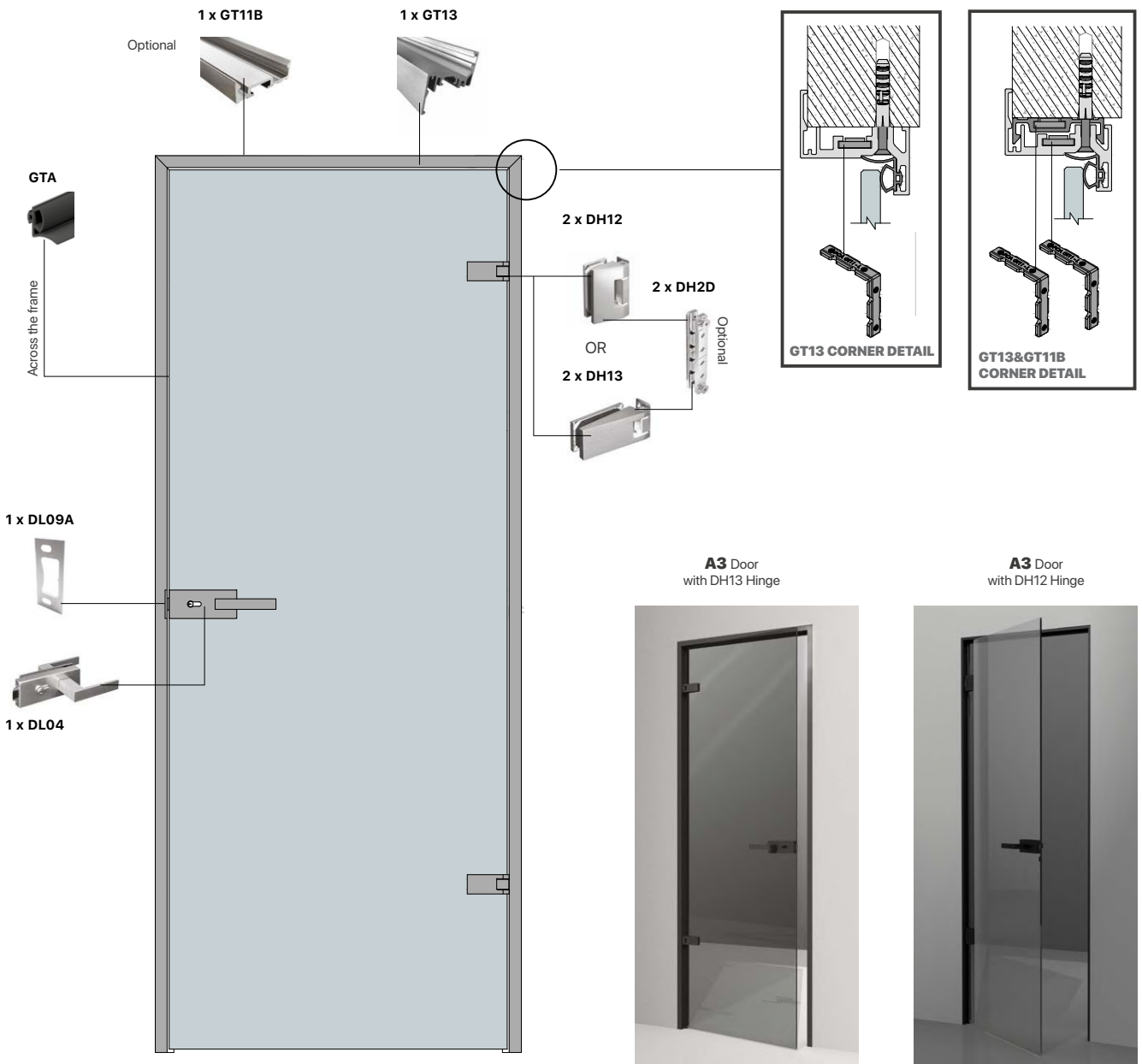

GT13 and GT13 with GT11B Frame Section Details

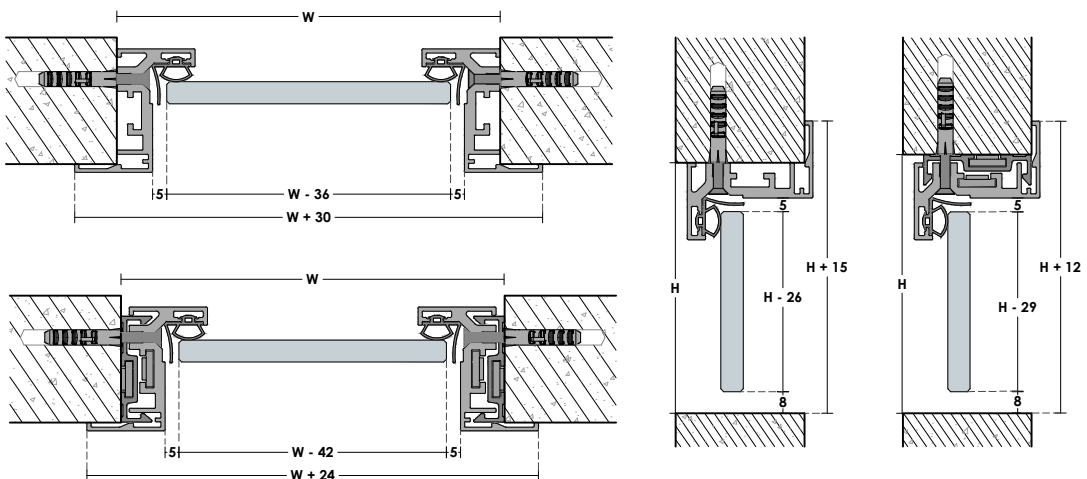

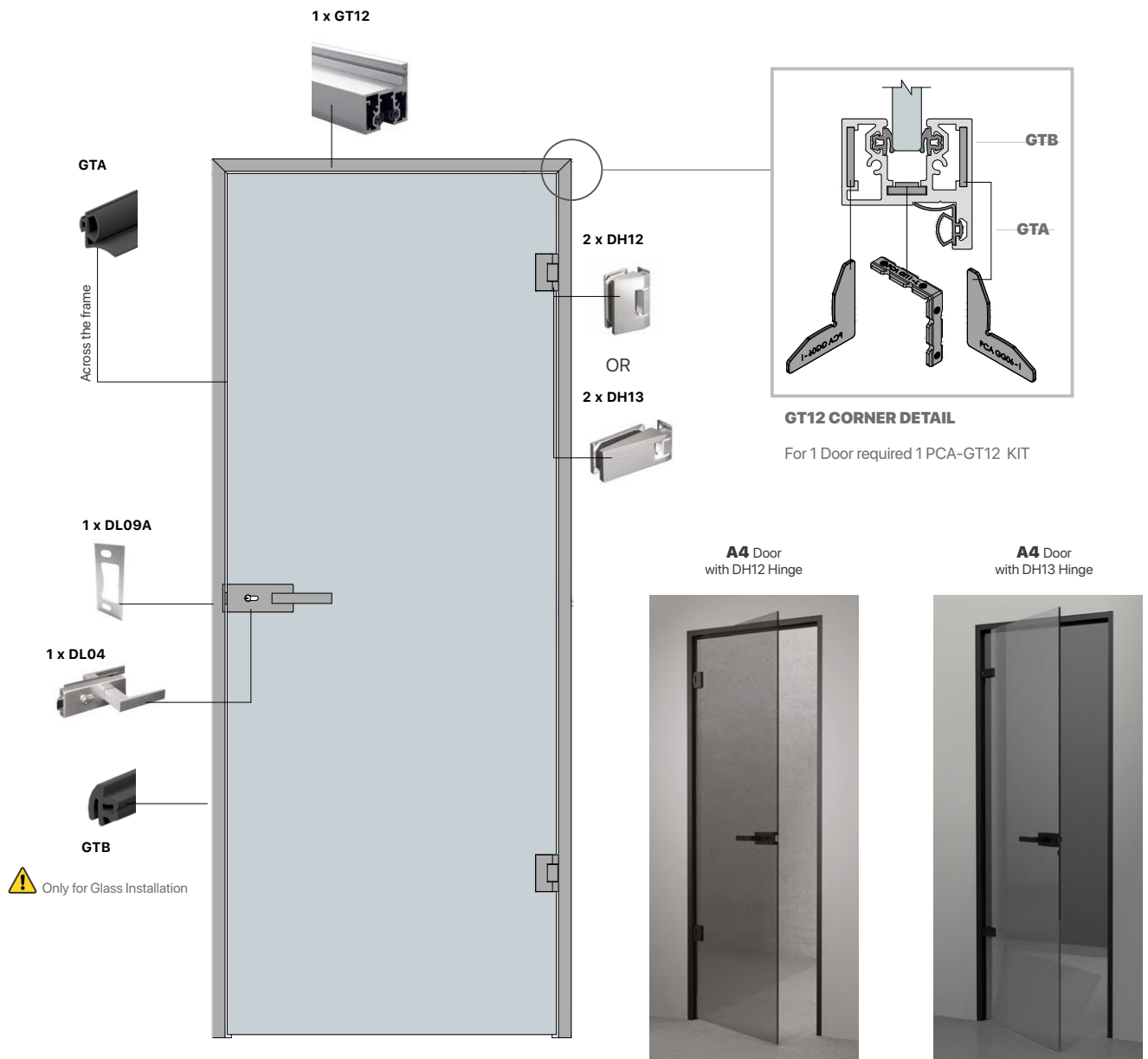

GT12 Frame Section Details

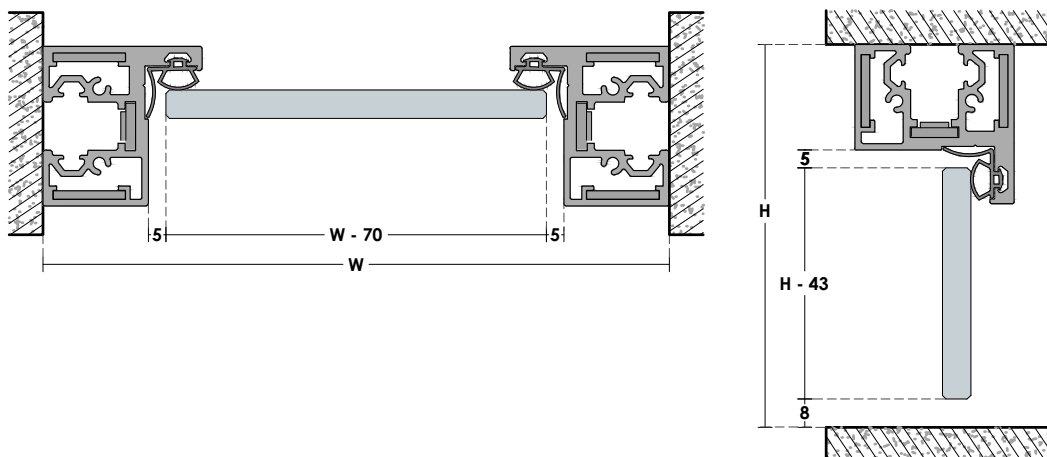



NEW

DOOR FRAME SERIES | **A5**

DOORS

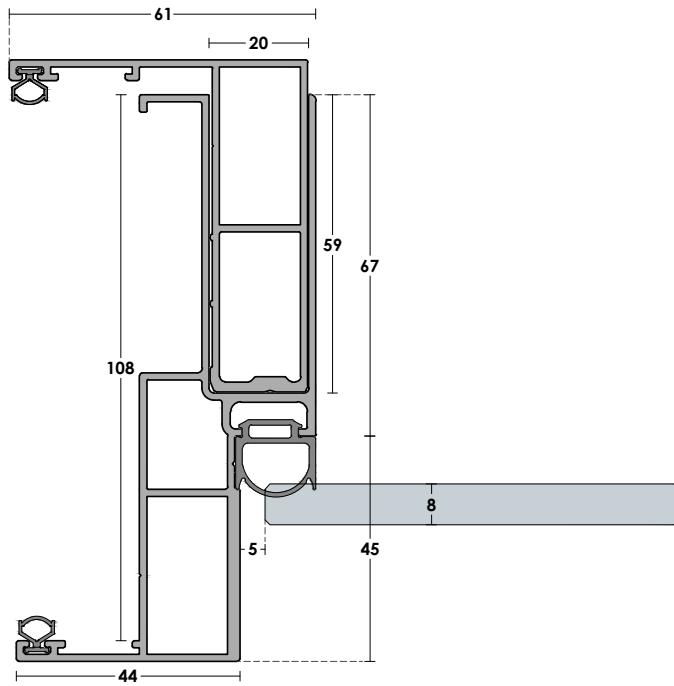

GT60 | 105-160mm

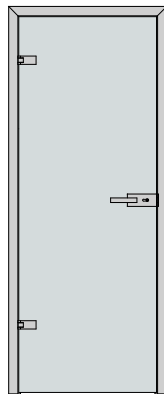
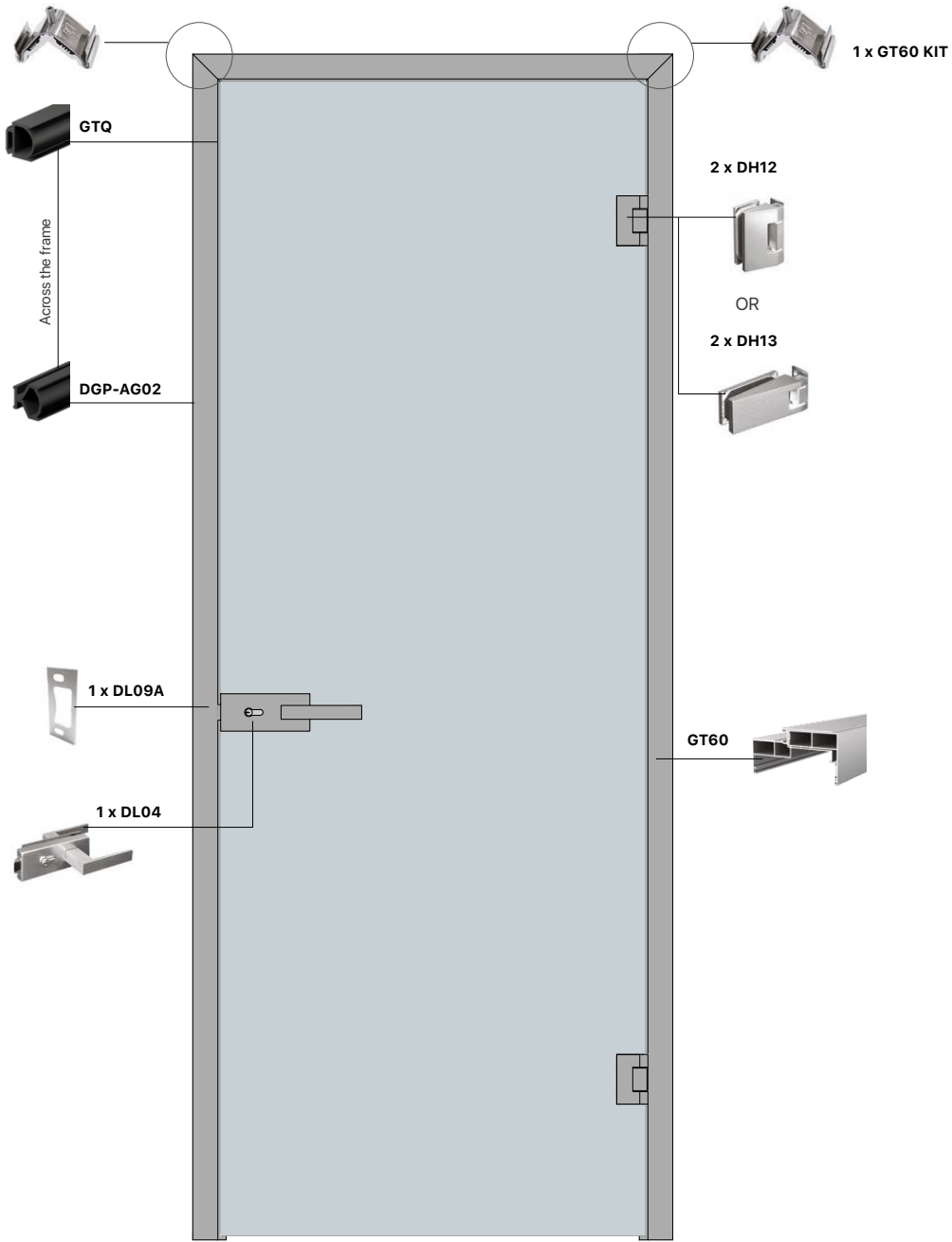

A5 Door
with DH13 Hinge

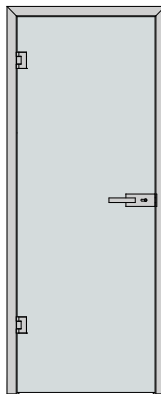

A5 Door
with DH12 Hinge

A5-S SIMONSWERK HINGE

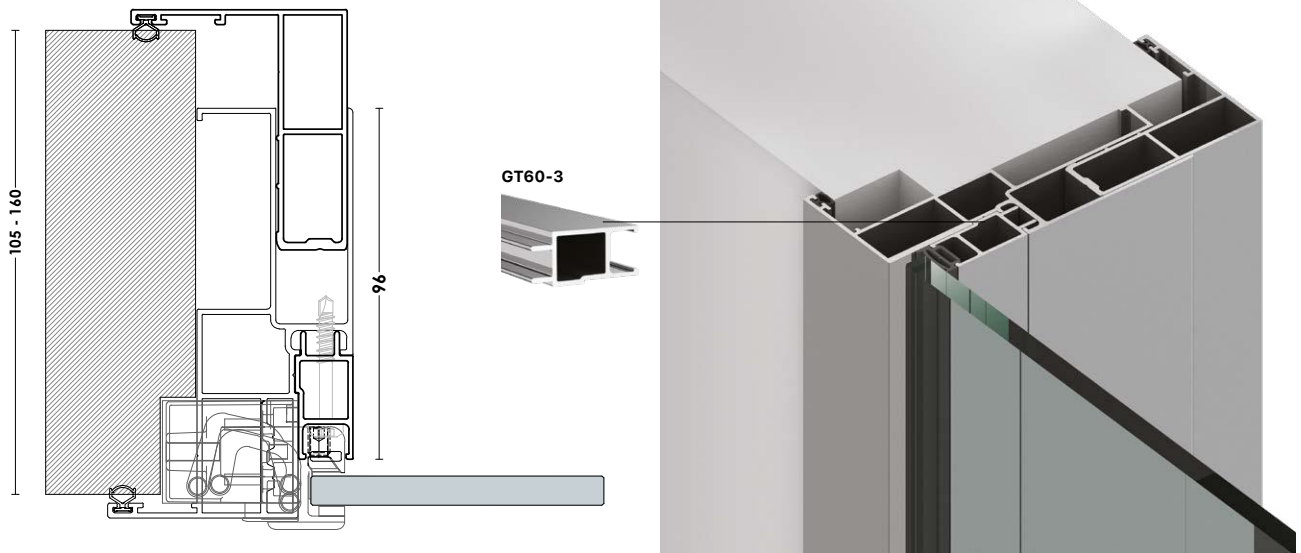

DOORS

SIMONSWERK

The TECTUS Glass hinge system is capable of supporting up to 80 kg. This corresponds to a glass door with dimensions of approx. 10 x 1000 x 2700 mm using tempered safety glass measuring 8 or 10 mm thick.

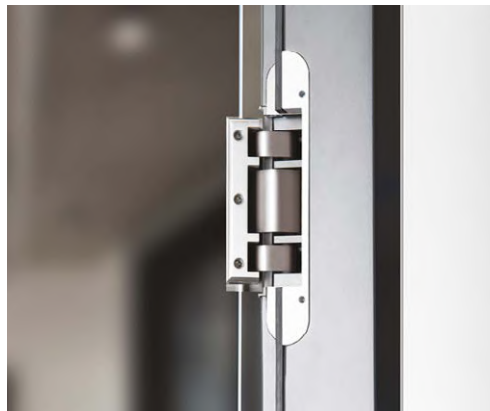



FULL FRAME DOOR SERIES

A20

DOORS



A21 | GT10 profile



A22 | GT11 profile

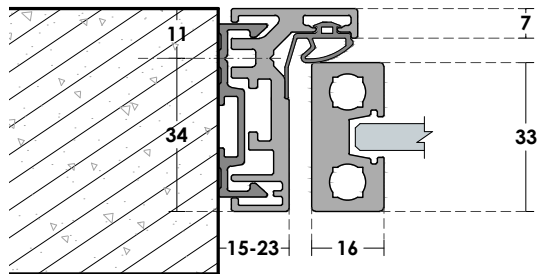
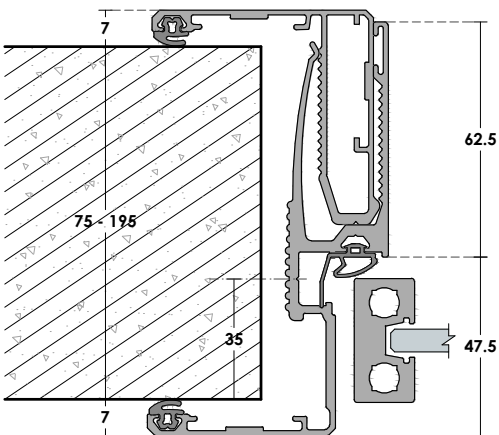

pg. 128

pg. 129

A23 | GT13 profile



A24 | GT12 profile



DOORS

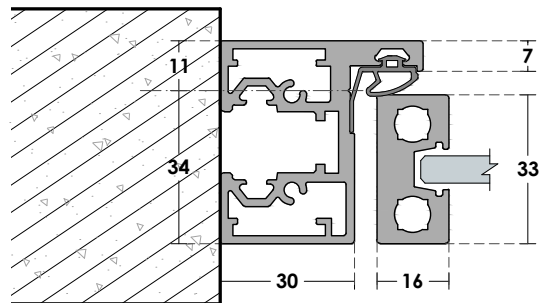
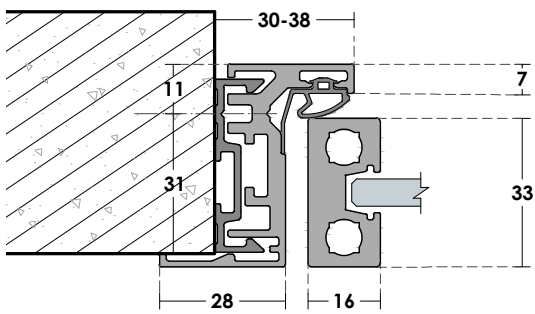
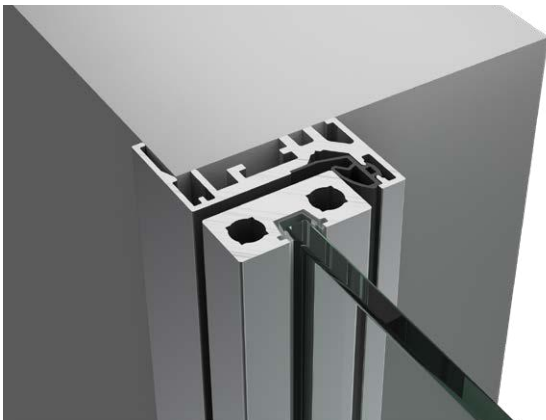

pg. 130

pg. 131

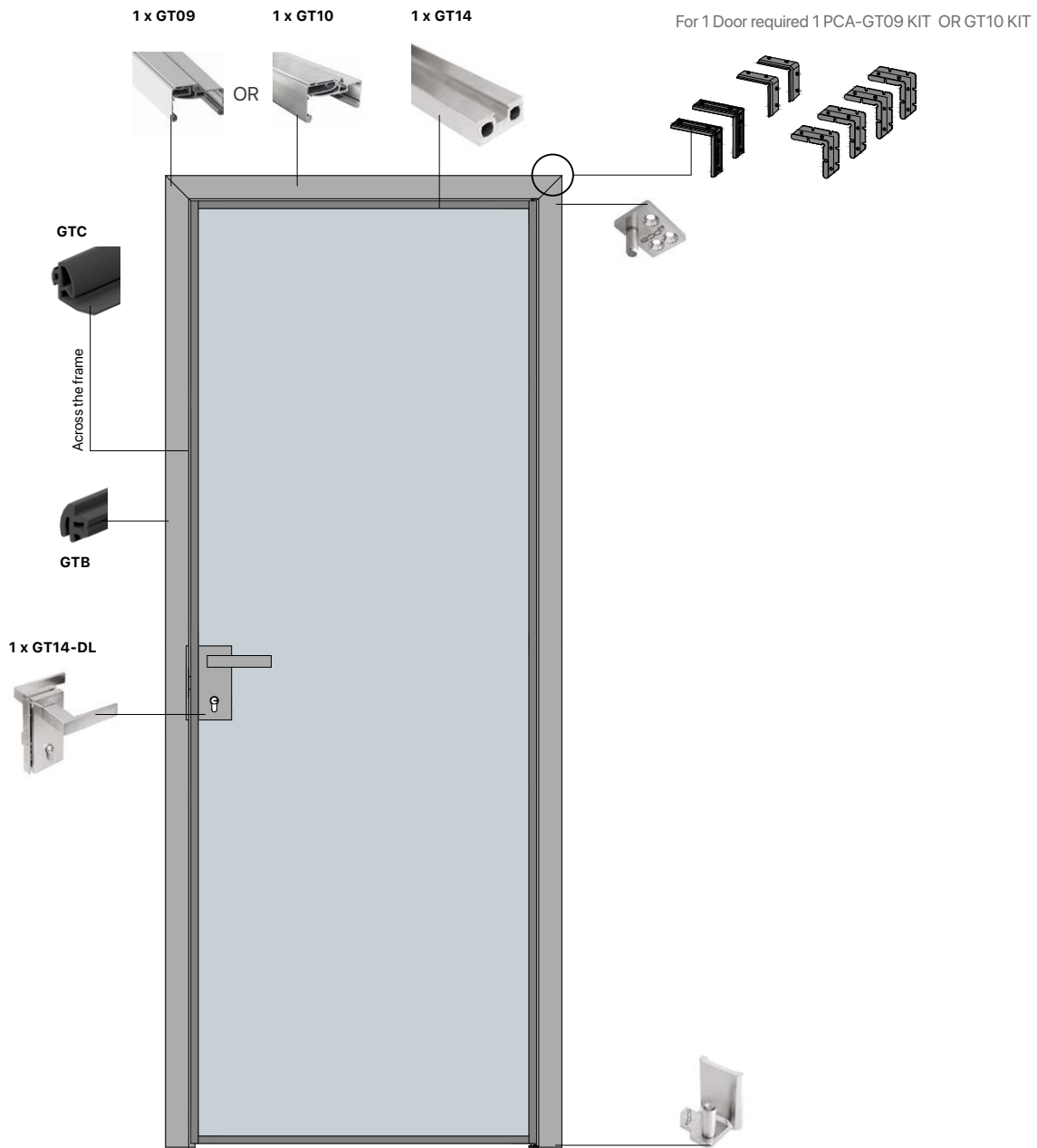

GT10 Frame | GT14 Door Installation

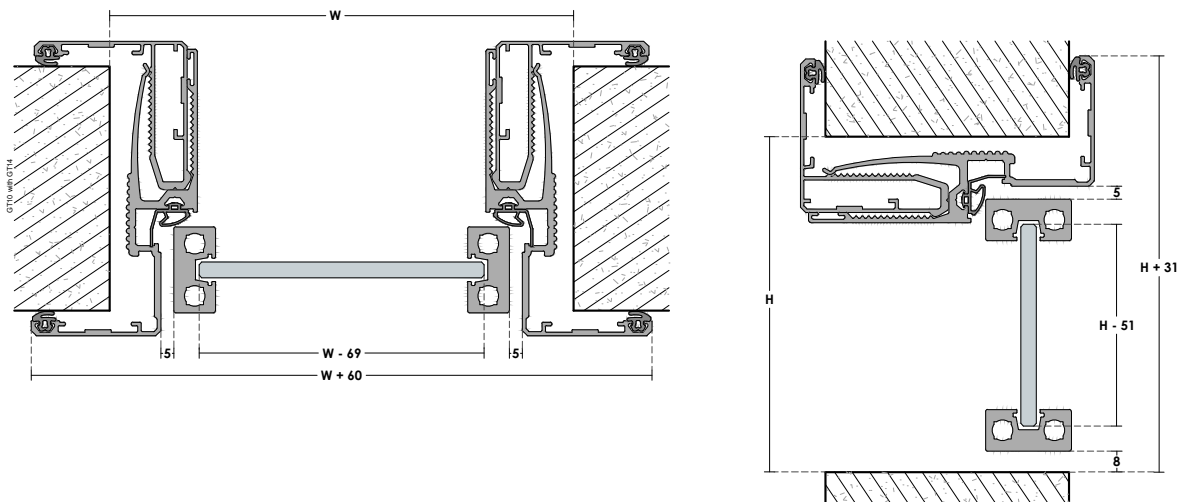

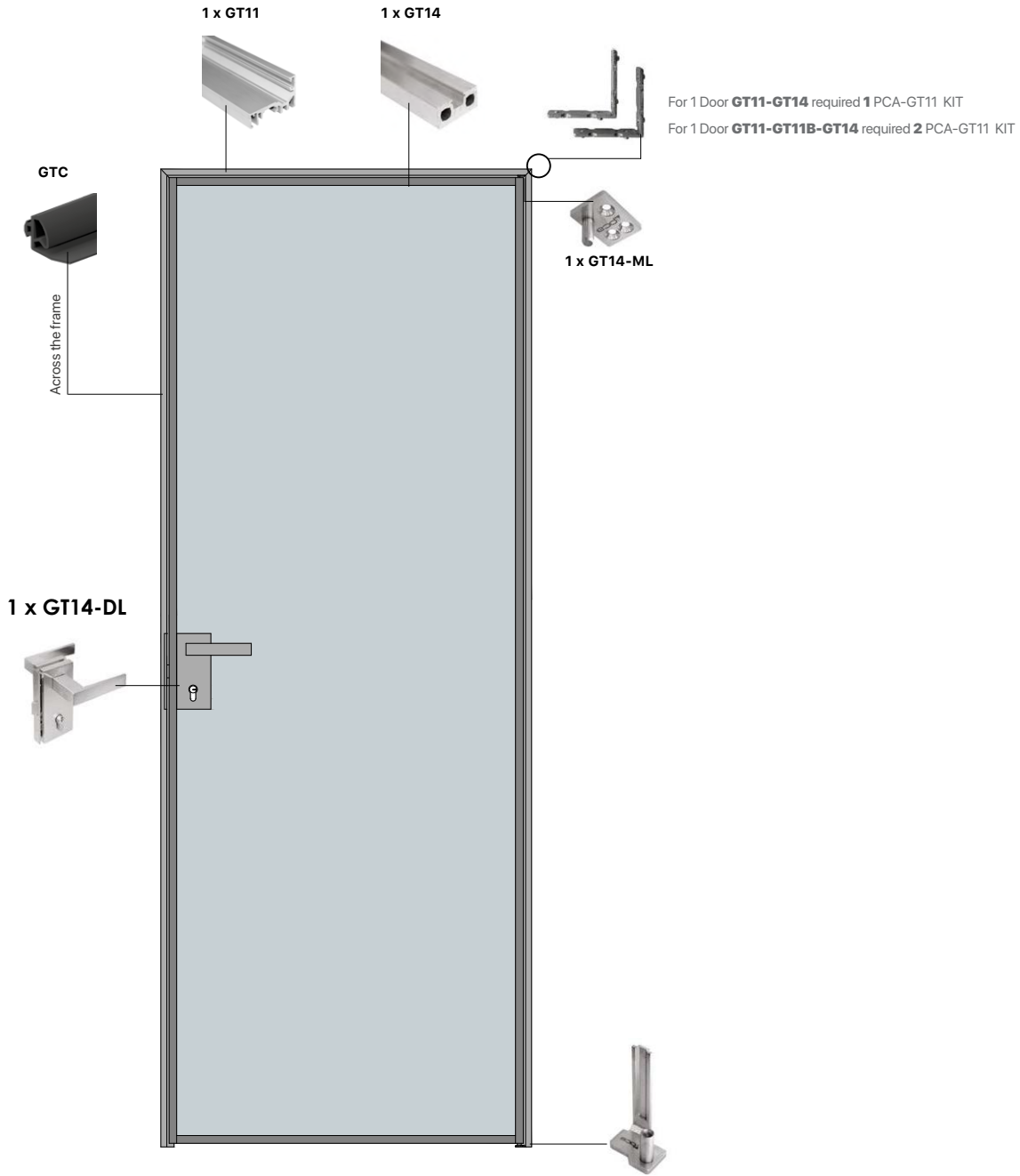

GT11|GT11-GT11B Frame | GT14 Door Section Details

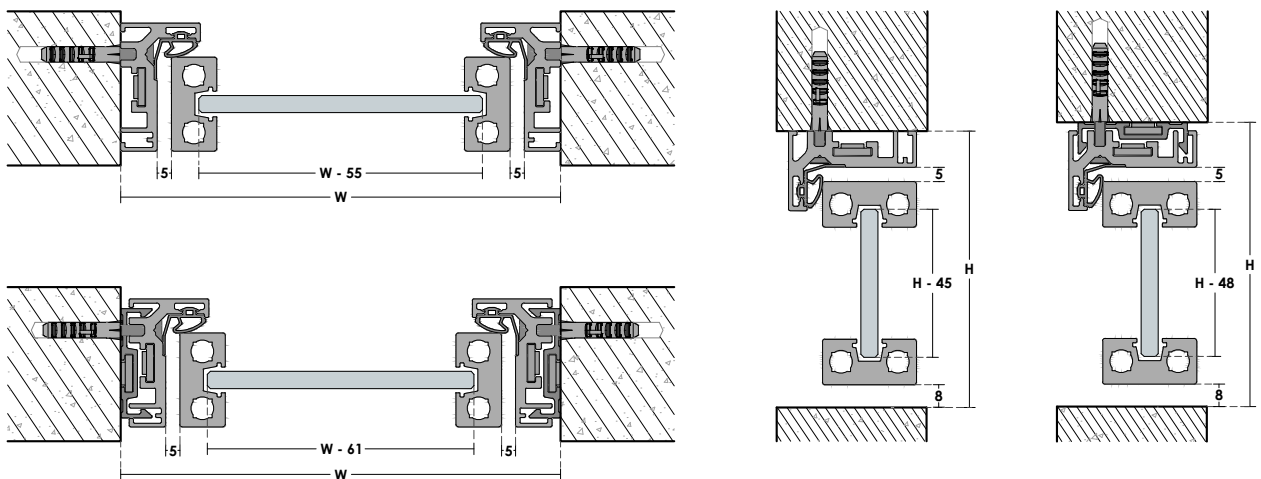

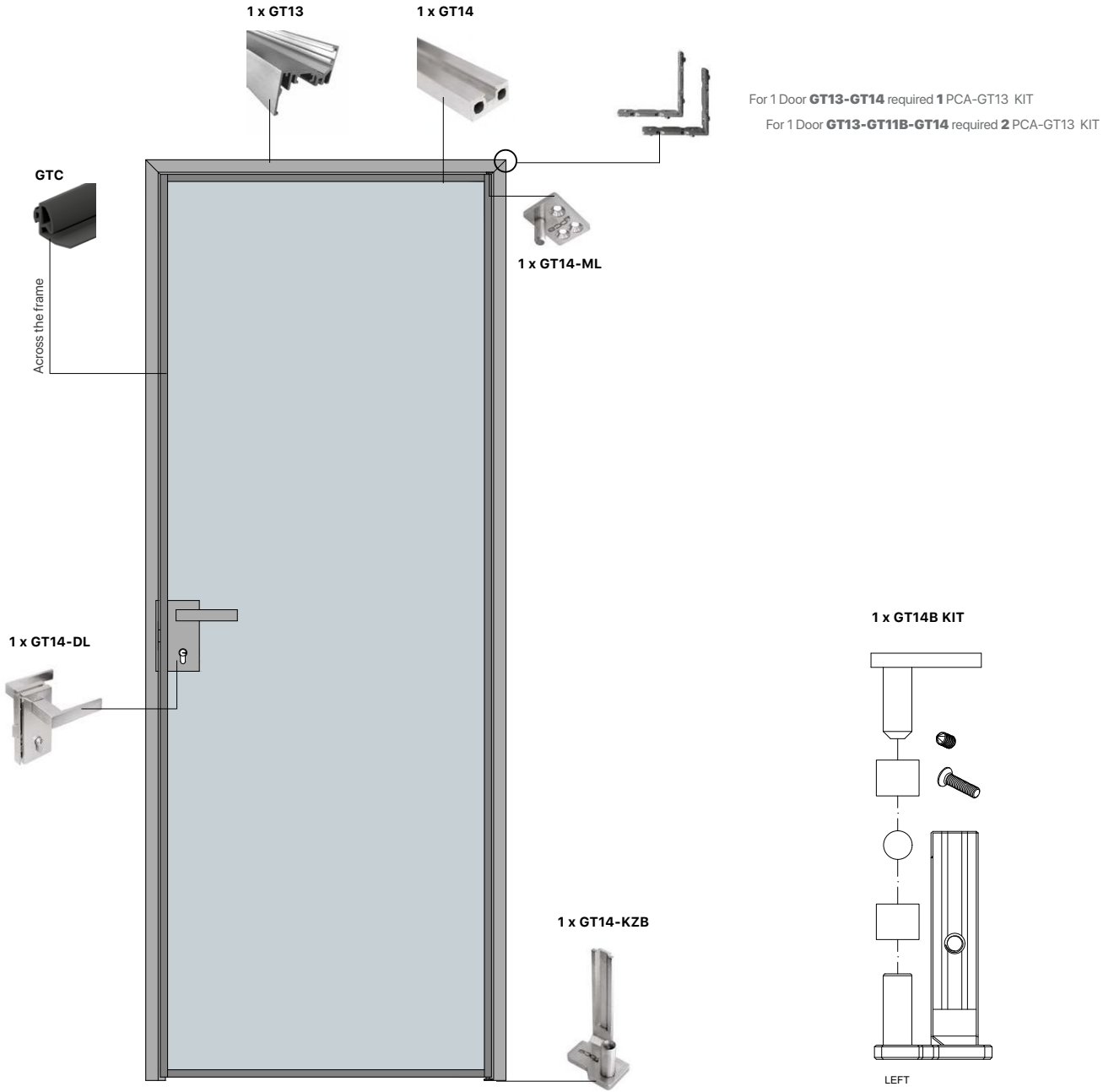

GT13 Frame | GT14 Door Section Details

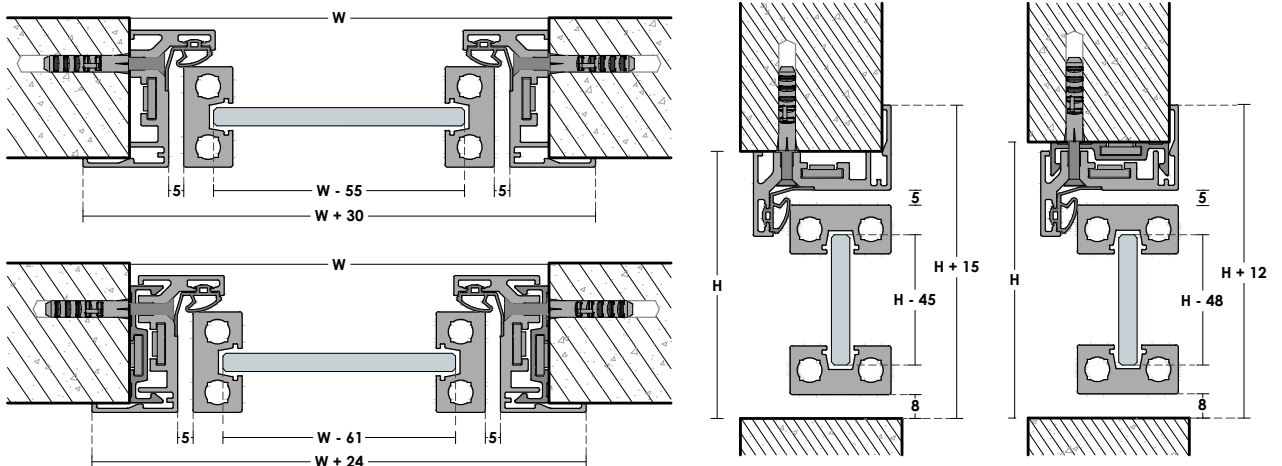

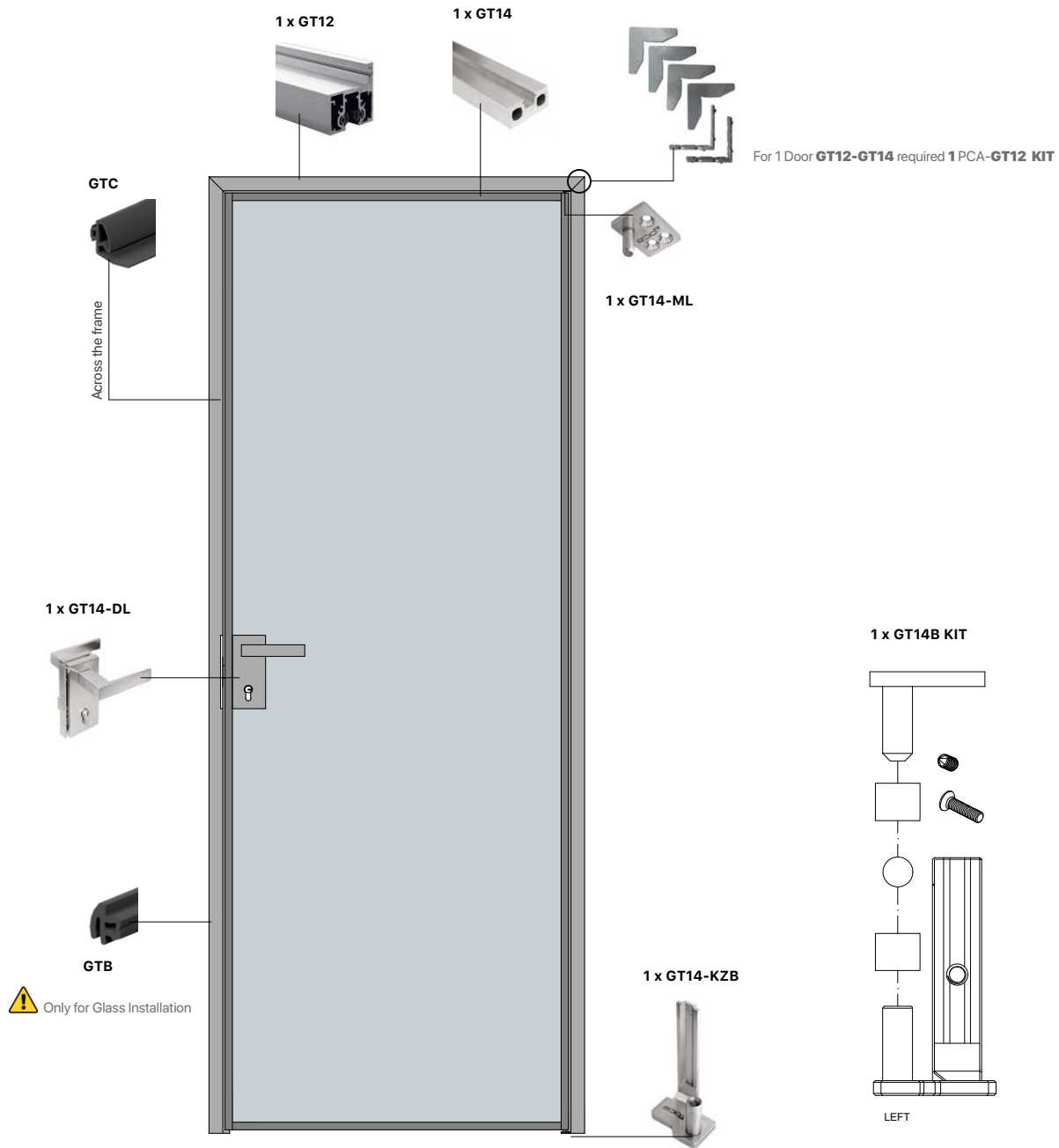

GT12 Frame | GT14 Door Section Details

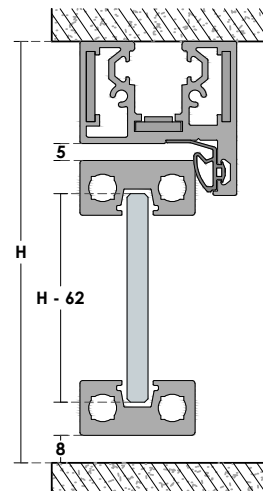
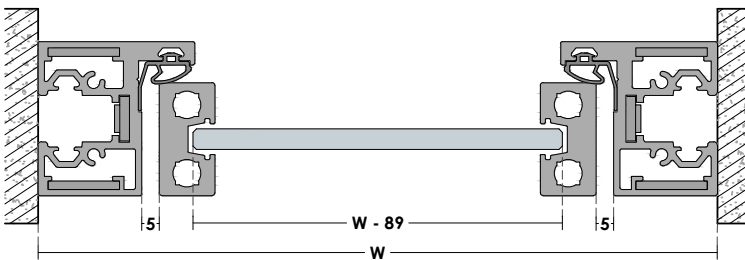



NEW

FULL FRAME DOOR SERIES

A25

DOORS

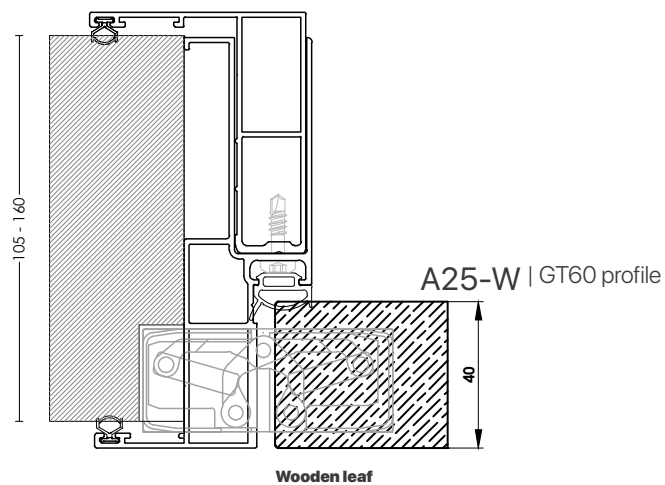
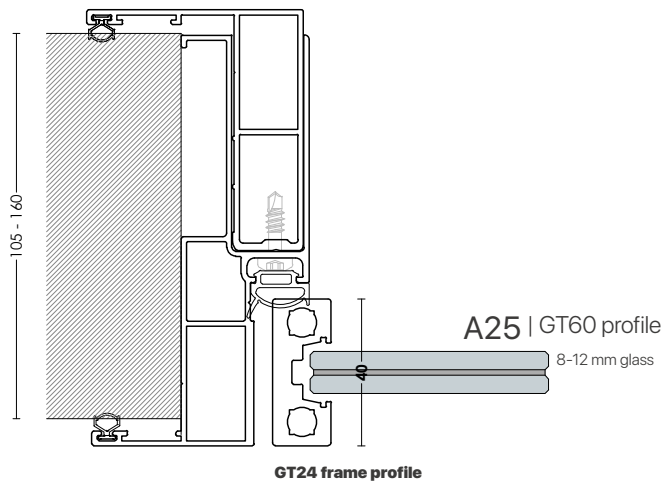
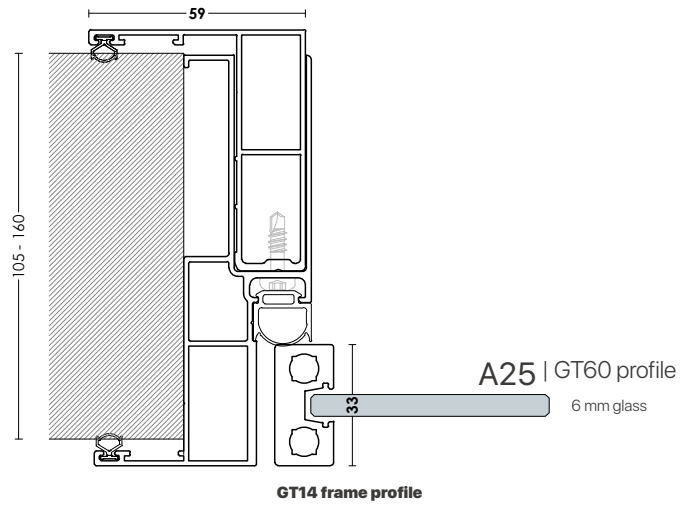

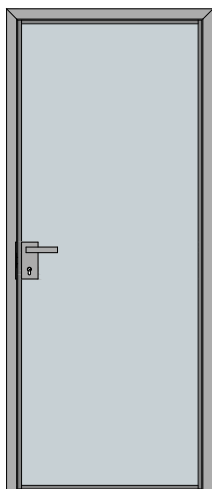
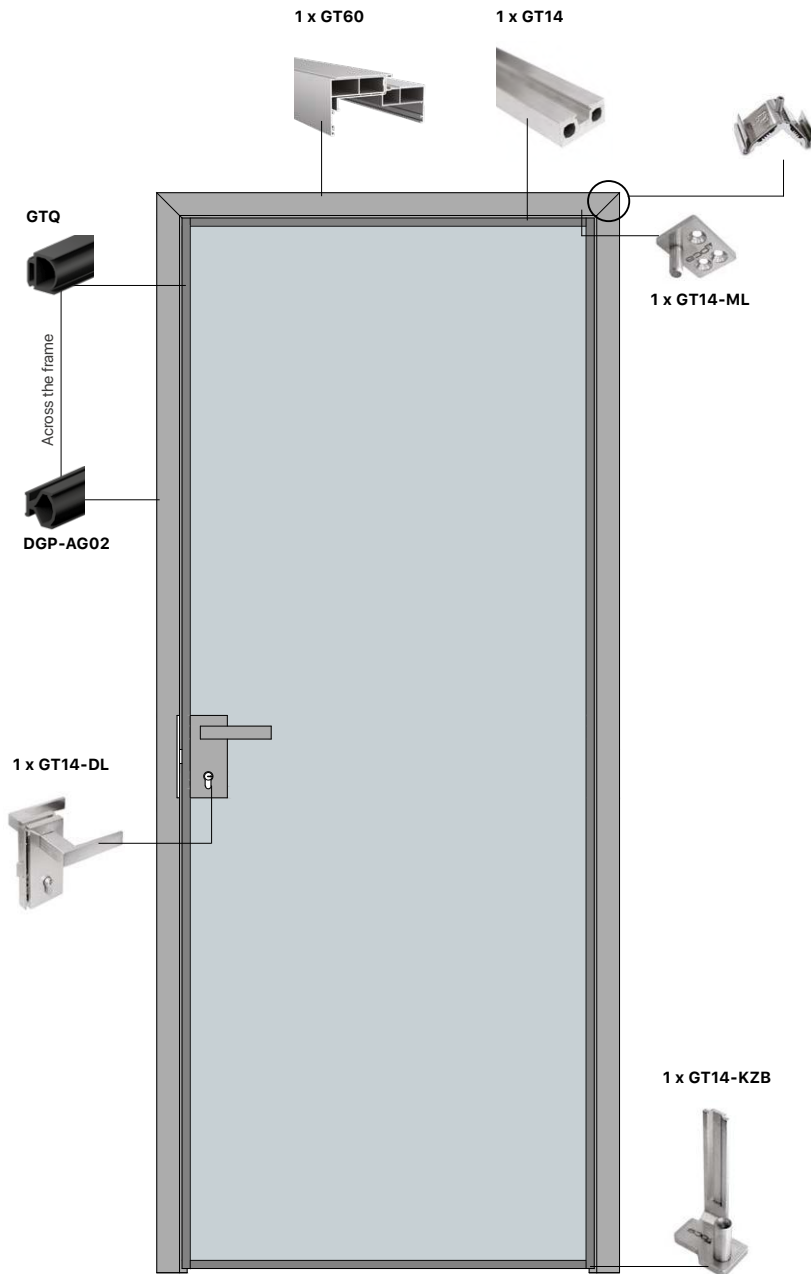

A25 Door
GT14 frame

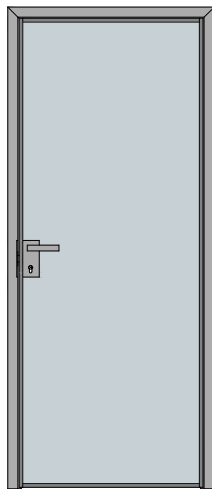

A25 Door
GT24 frame



A25-W Door
Wooden leaf



A25 6 mm GLASS THICKNESS



A25 8-12 mm GLASS THICKNESS



A25-W WOODEN LEAF





OFFICE PARTITIONS

A8 |

PARTITION SERIES

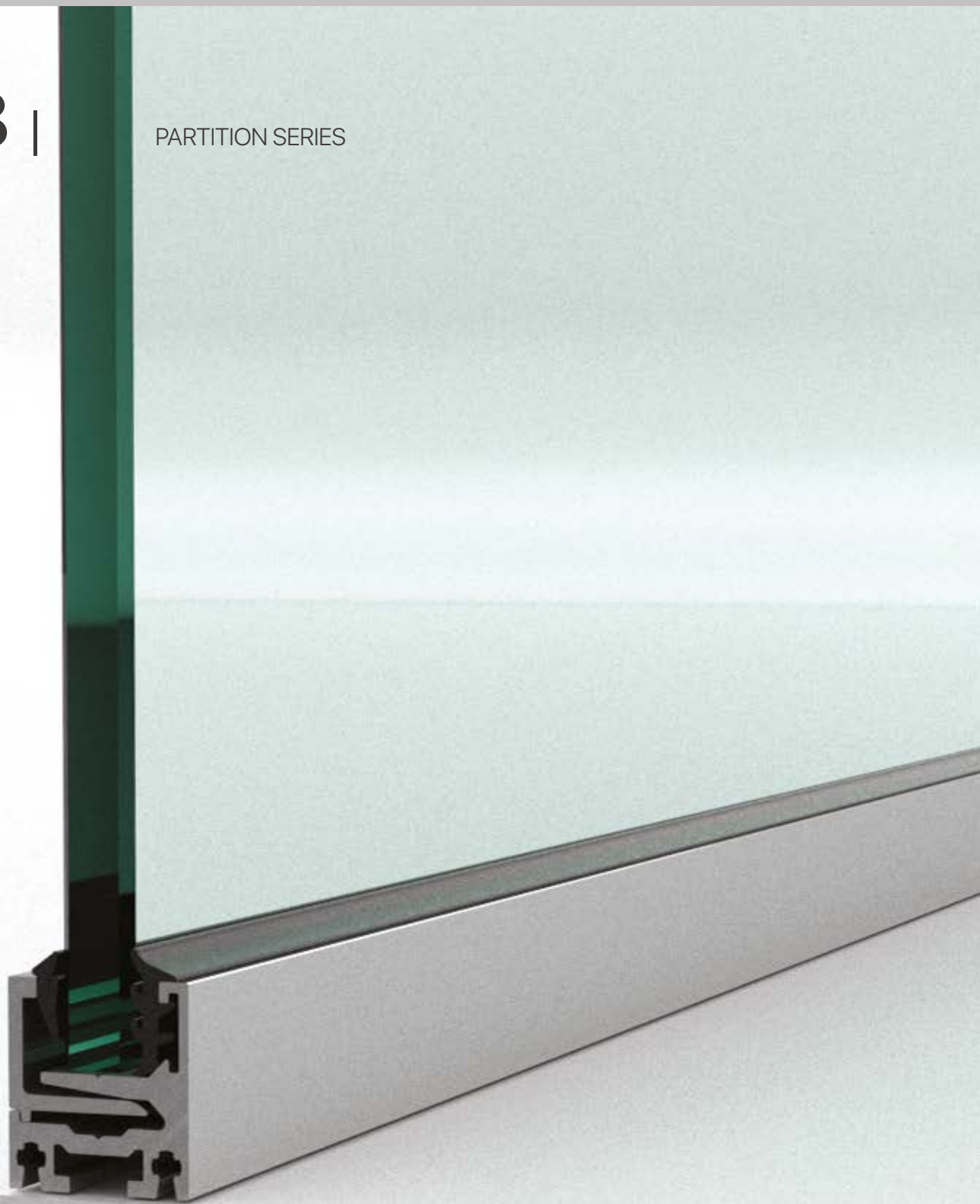

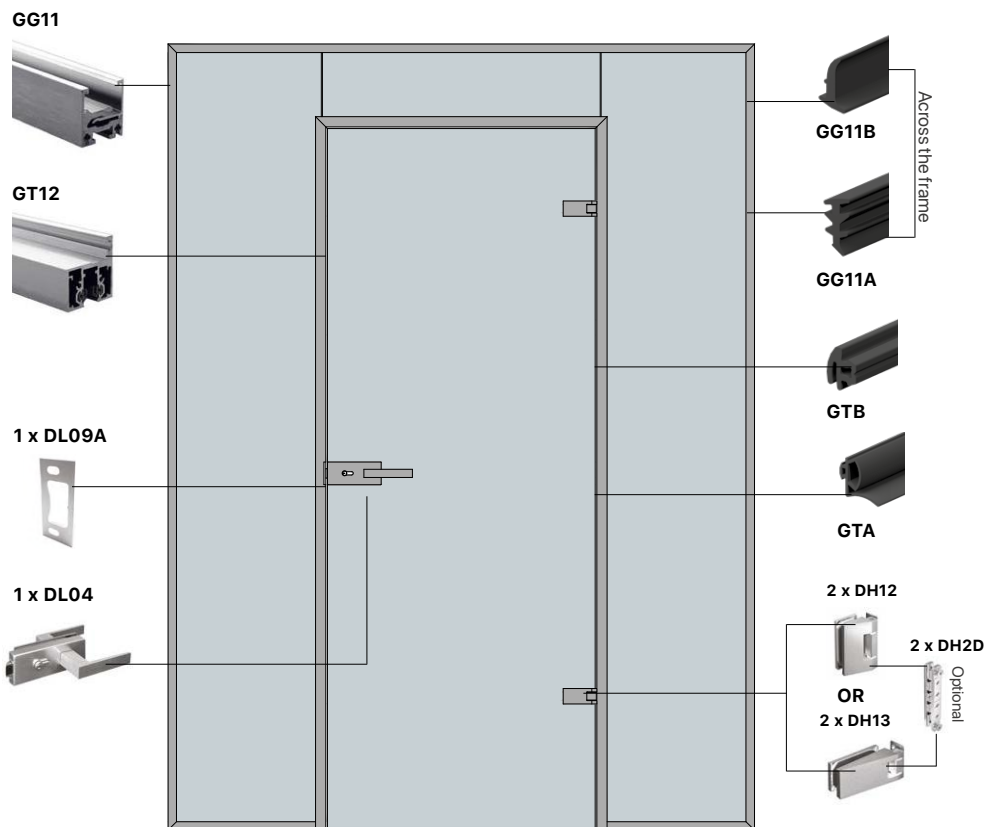

For GG11 Frame and GT12 Door required 2xGG11 KIT and 1xGT12 KIT

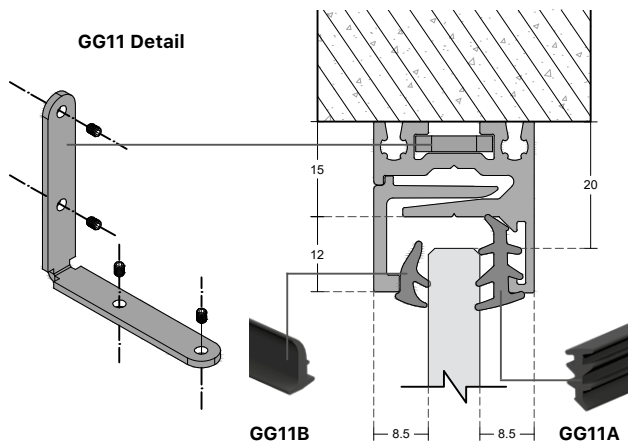
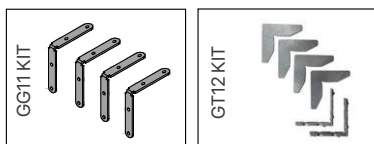

TYPOLOGIES

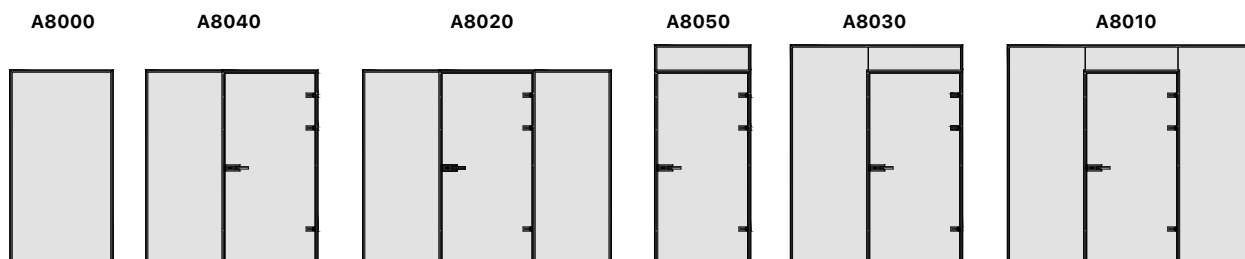

A9 |

PARTITION SERIES



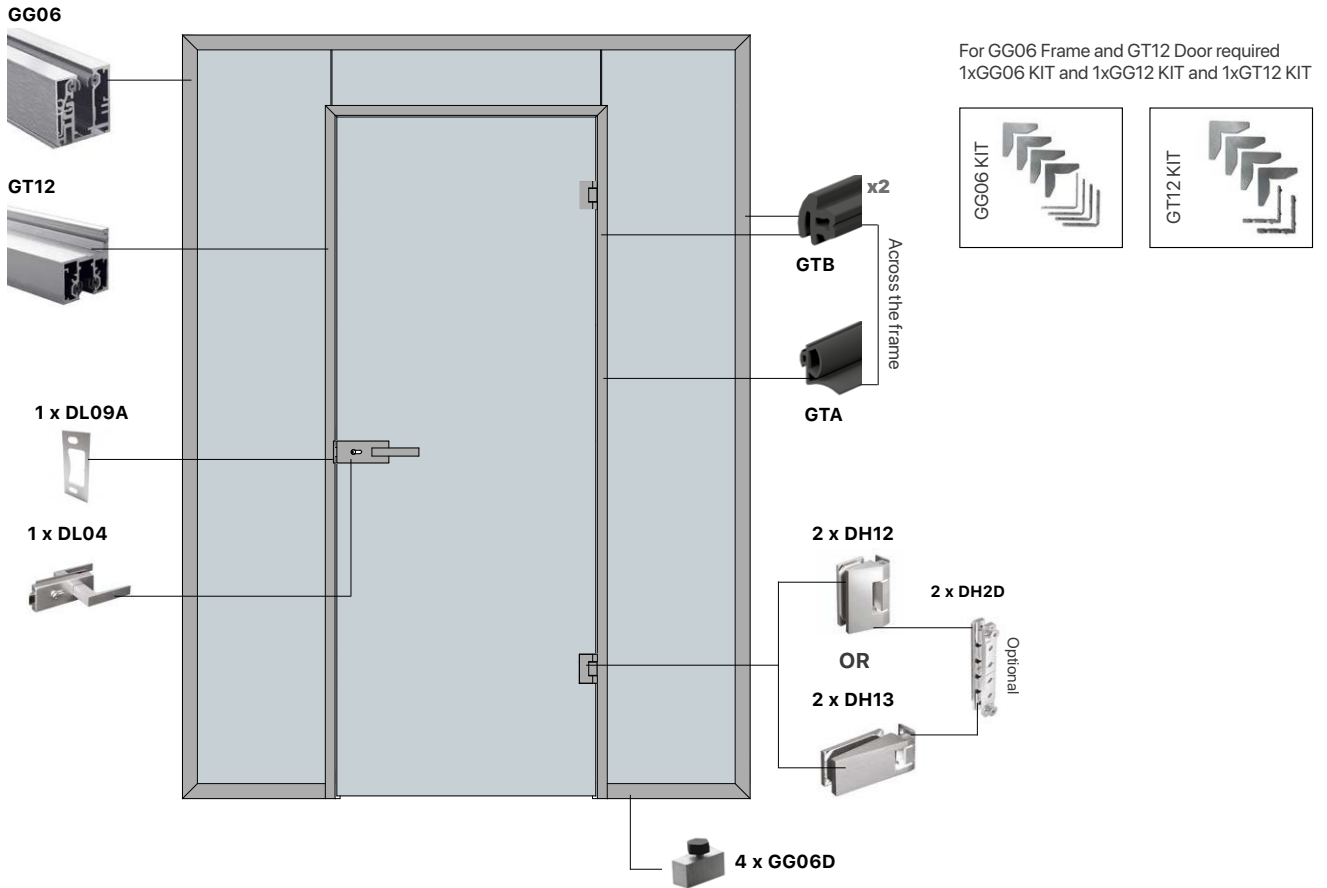

OFFICE PARTITIONS

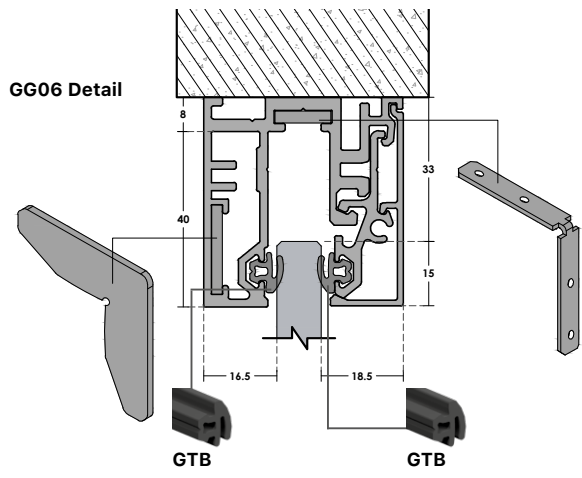

TYPOLOGIES

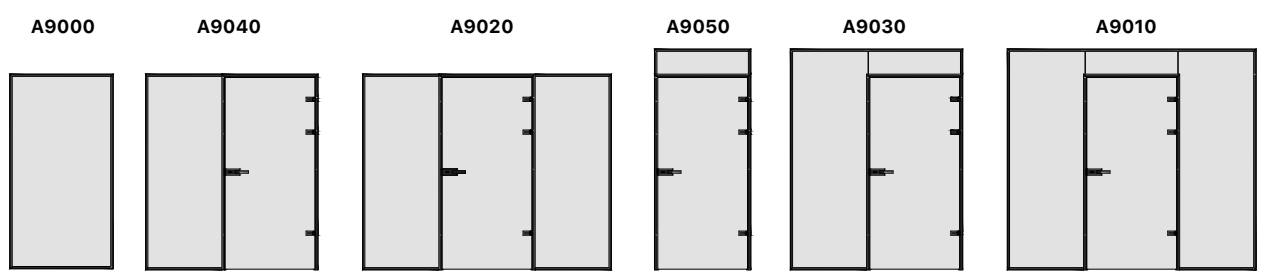

A10

PARTITION SERIES

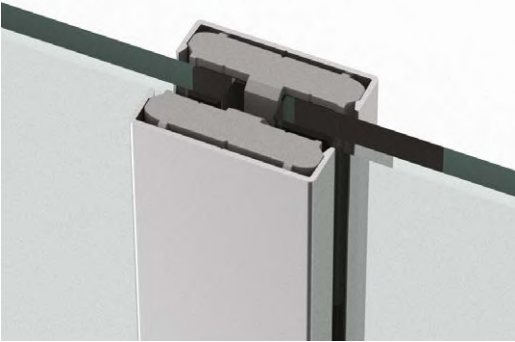
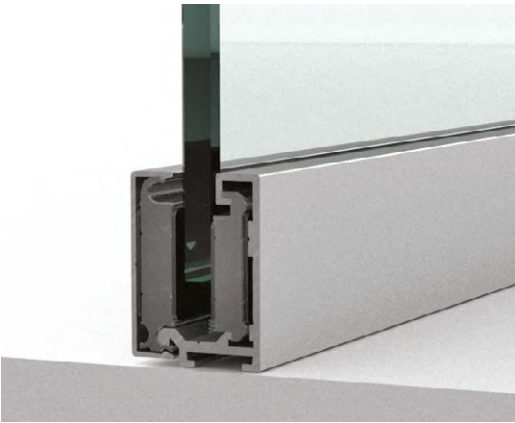



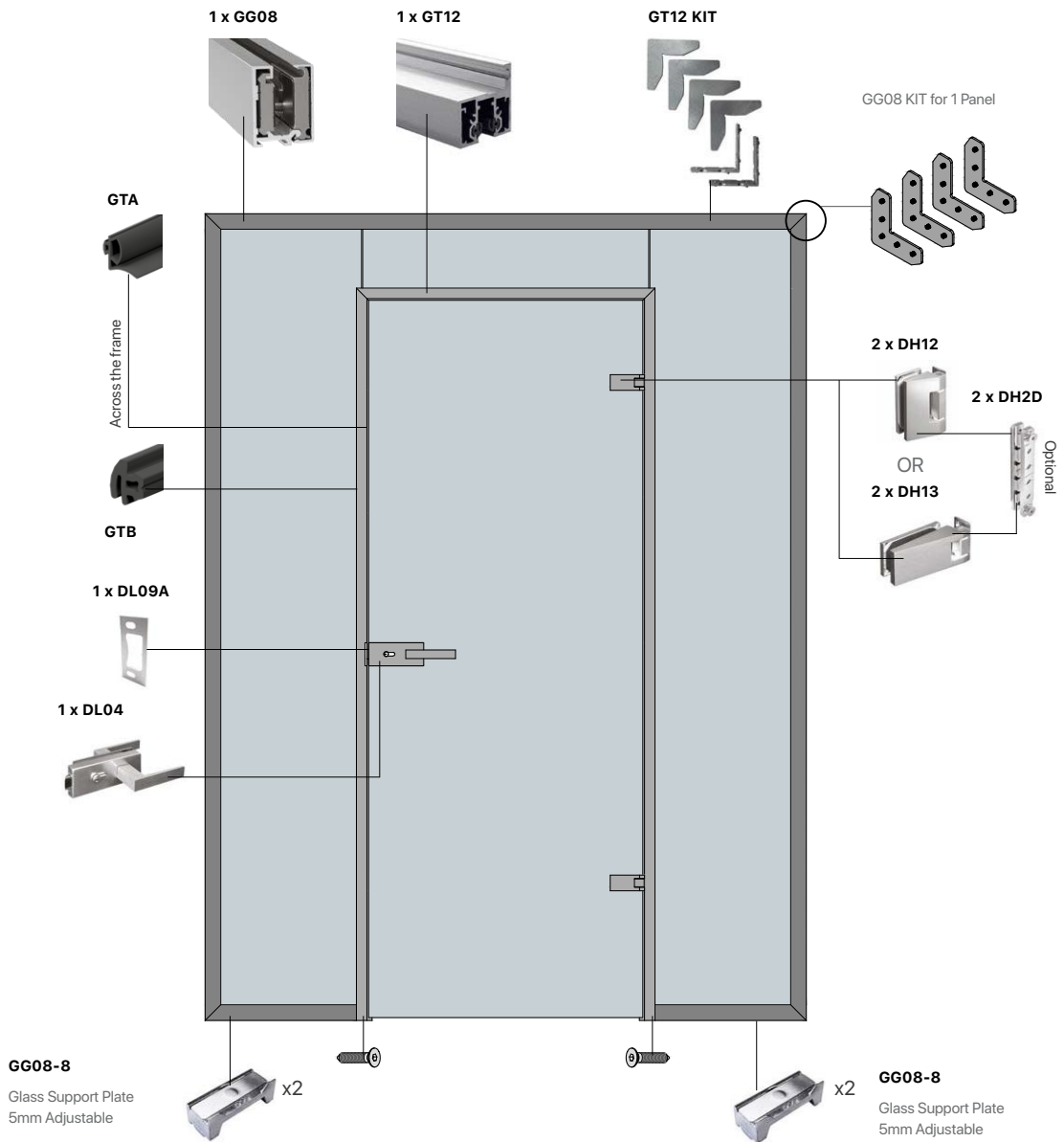

For 1 **GG08** Frame with **GT12** door required 1 **PCA-GG08 KIT**

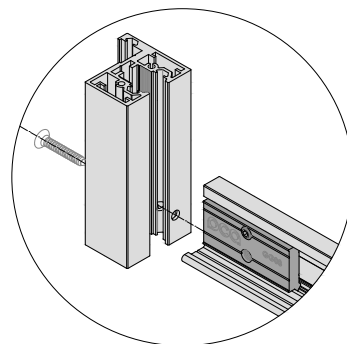
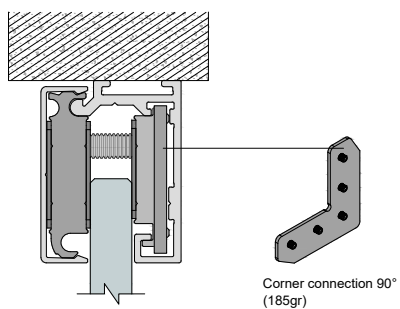

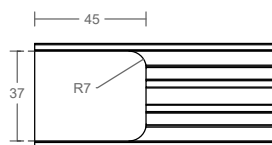
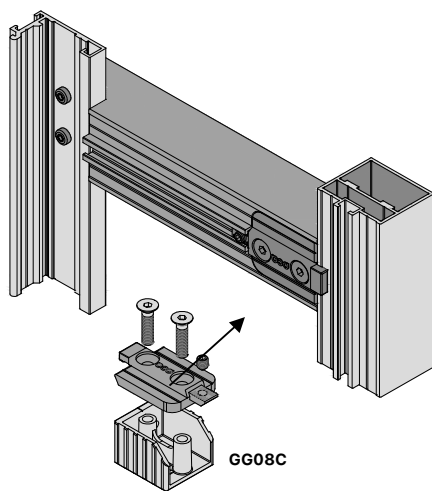
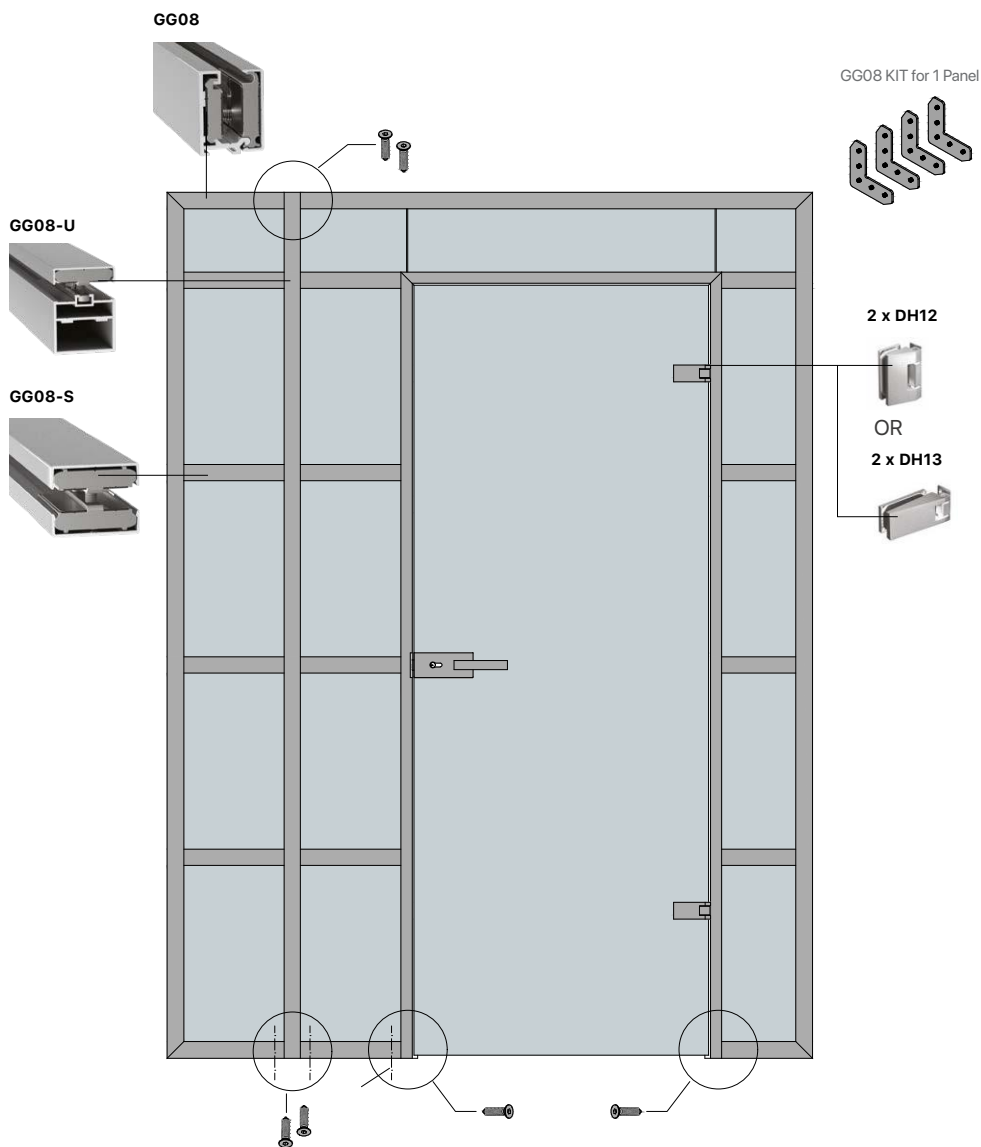

A11 |

PARTITION SERIES

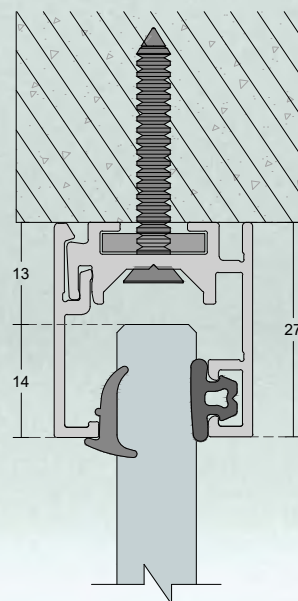

GG12

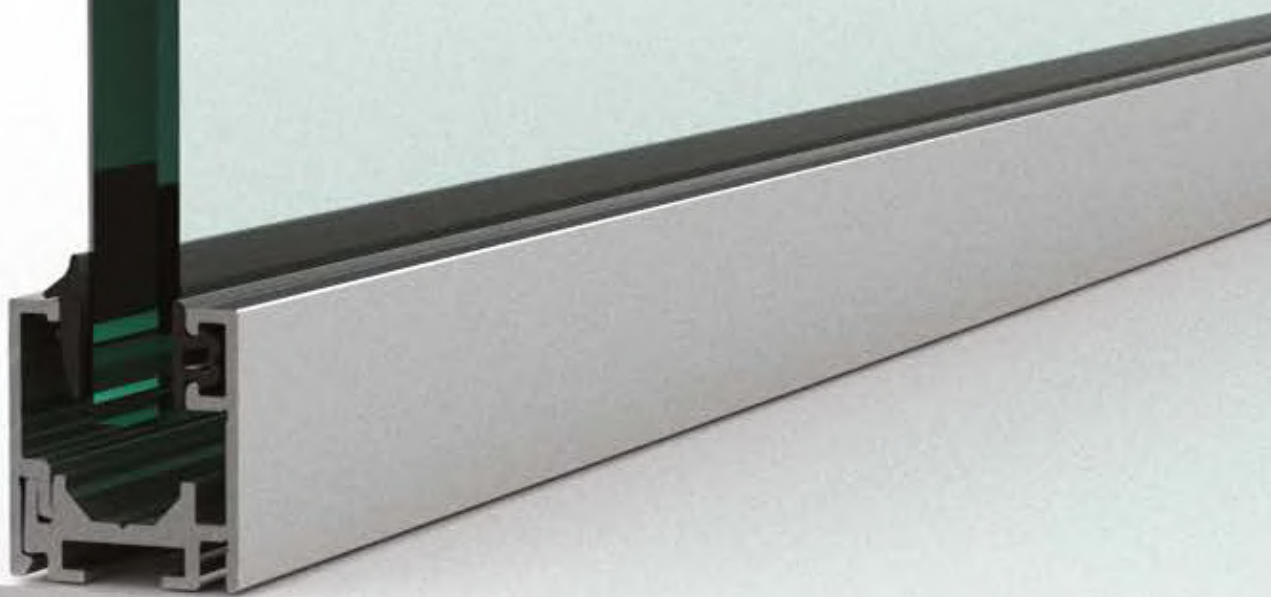

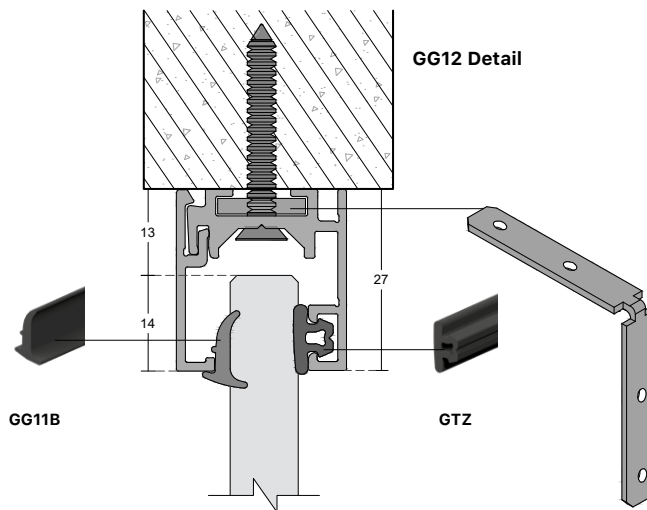
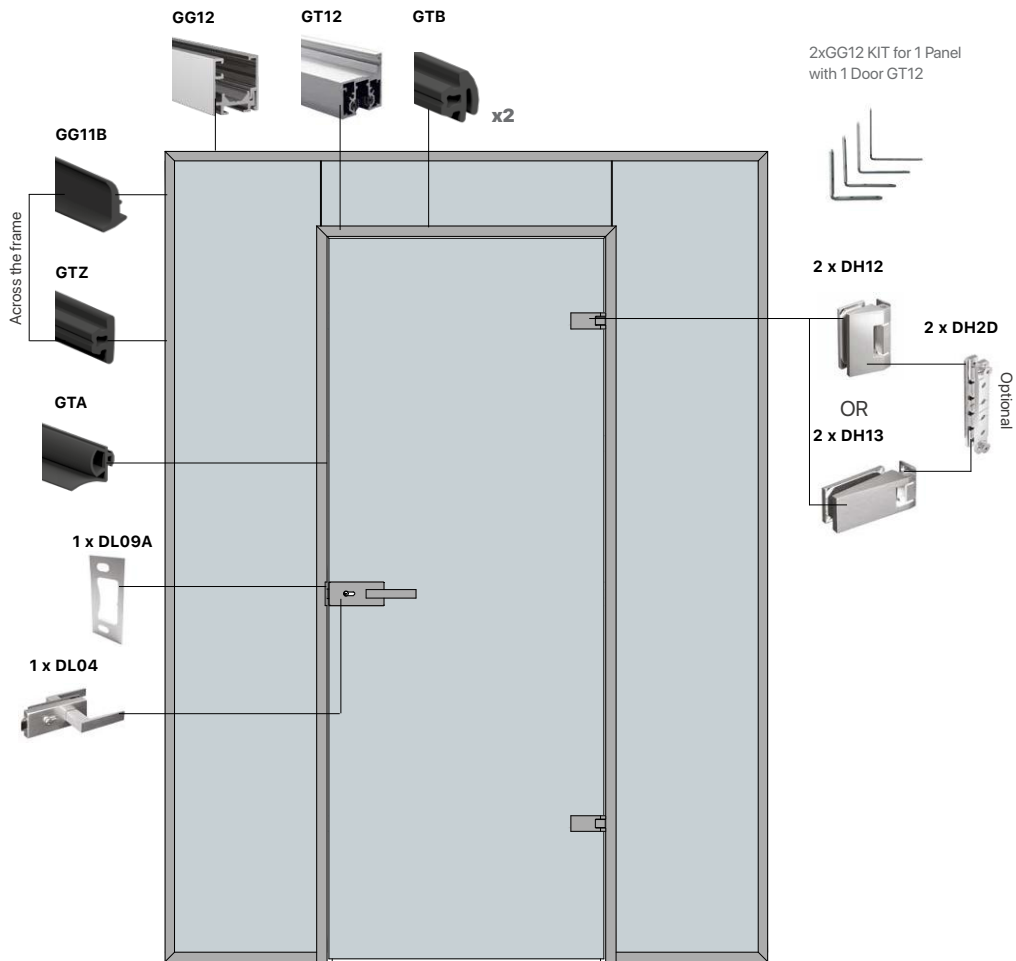

TYPOLOGIES

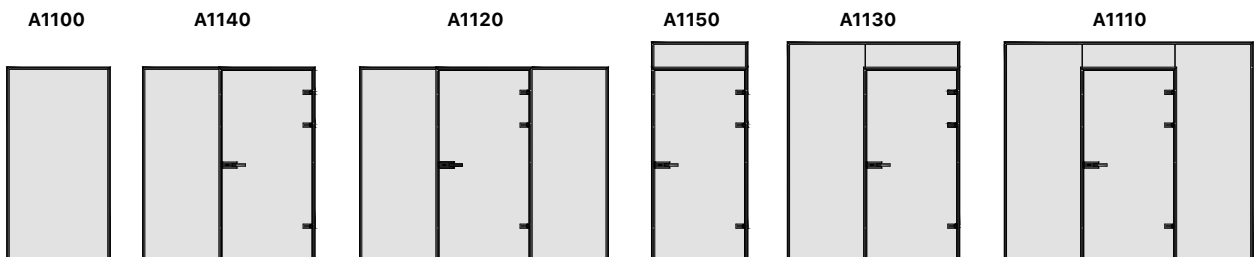

DOORS & OFFICE PARTITIONS
PRODUCT LIST

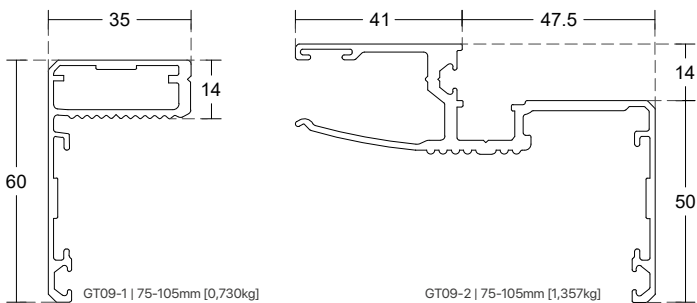

PCA-GT09
Door Frame Profile

580cm | Length
2,087kg | Weight/meter
10mm | Glass Thickness
Aluminium | Material
Natural Anodize, Satin | Finish

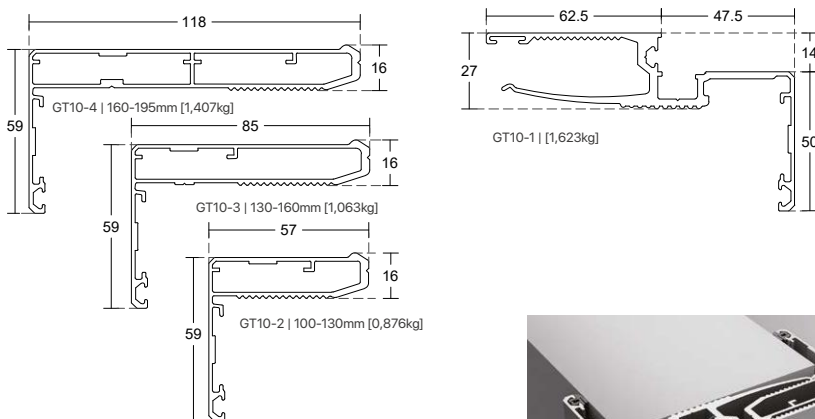

PCA-GT10
Door Frame Profile

580cm | Length
Aluminium | Material
Natural Anodize, Satin | Finish

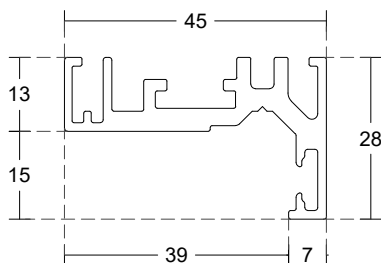

PCA-GT11
Door Frame Profile

580cm | Length
0,822kg | Weight/meter
Aluminium | Material
Natural Anodize, Satin, Black Anodize | Finish



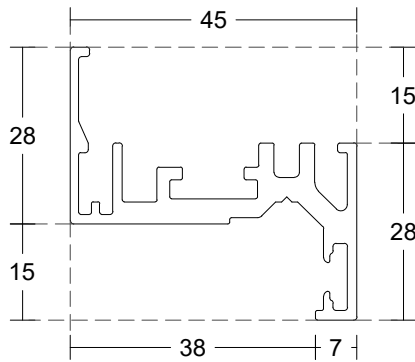

PCA-GT13
Door Frame Profile
 580cm | Length
 0,887kg | Weight/meter
 Aluminium | Material
 Natural Anodize, Satin | Finish

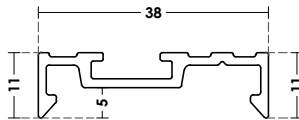

PCA-GT11B
Door Frame Alignment Profile
 580 cm | Length
 0,307kg | Weight/meter
 Aluminium | Material
 Natural Anodize, Satin | Finish

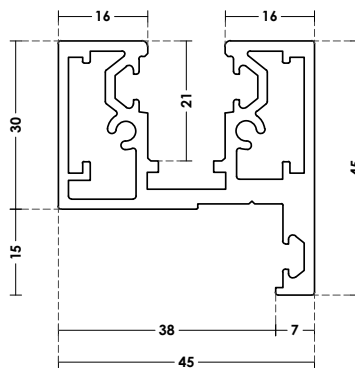

PCA-GT12
Door Frame Profile
 580 cm | Length
 10mm | Glass Thickness
 1,447kg | Weight/meter
 Aluminium | Material
 Natural Anodize, Satin, Black Anodize | Finish



NEW

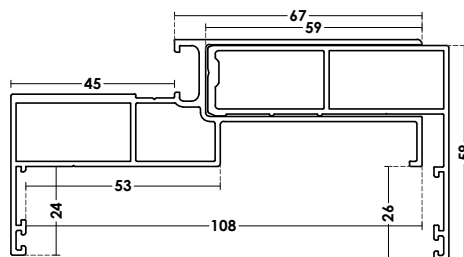
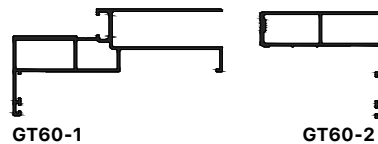

PCA-GT60

Door Frame Profile

580cm | Length

2,373 kg | Weight/meter

Aluminium | Material

Natural Anodize, Satin, Black Anodize | Finish



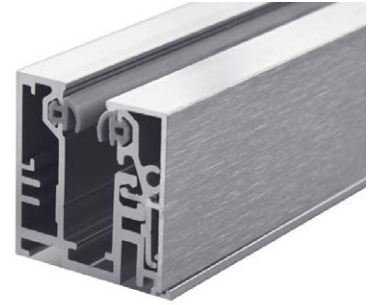
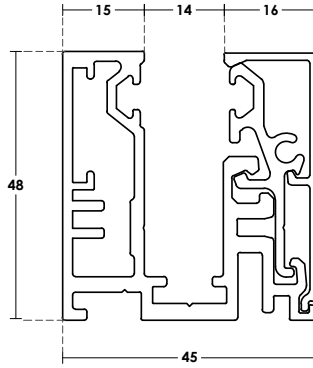
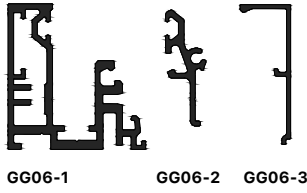

PCA-GG06
Partition Profile
 580 cm | Length
 10mm | Glass Thickness
 1,960kg | Weight/meter
 Aluminium | Material
 Natural Anodize, Satin, Black Anodize | Finish



PRODUCT LIST

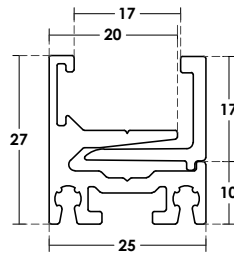

PCA-GG11
Partition Profile
 580 cm | Length
 8,10,12mm | Glass Thickness
 0,747kg | Weight/meter
 Aluminium | Material
 Natural Anodize, Satin | Finish

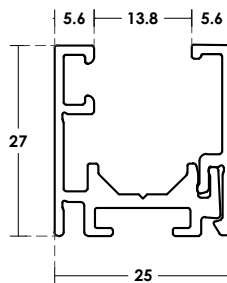
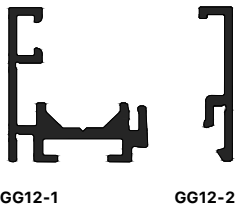

PCA-GG12
Door Frame Profile
 580cm | Length
 kg | Weight/meter
 10mm | Glass Thickness
 Aluminium | Material
 Natural Anodize, Satin, Black Anodize | Finish





PCA-GG08
Partition Profile

580cm | Length
8,10,12mm | Glass Thickness
Aluminium | Material
Natural Anodize, Satin, Black Anodize | Finish

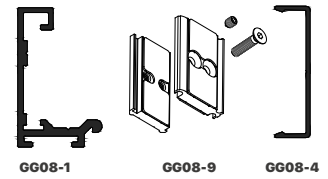
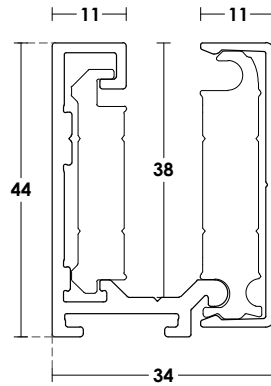

PCA-GG08-U
Partition Profile

350cm | Length
8,10,12mm | Glass Thickness
Aluminium | Material
Natural Anodize, Satin, Black Anodize | Finish

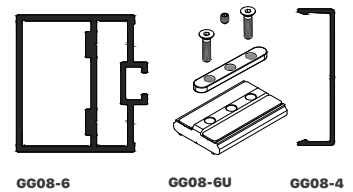
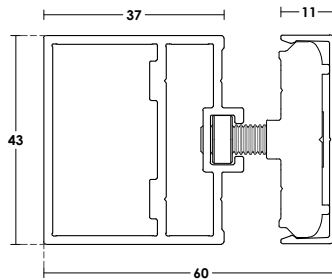

PCA-GG08-S
Partition Profile

580cm | Length
8,10,12mm | Glass Thickness
Aluminium | Material
Natural Anodize, Satin, Black Anodize | Finish

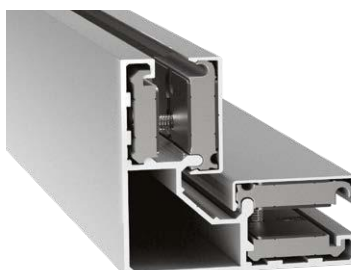
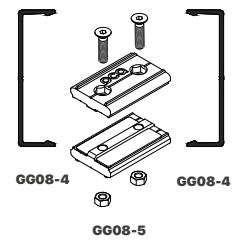
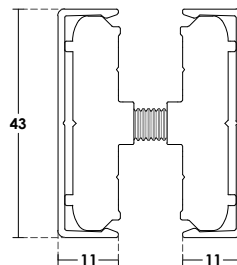

PCA-GG08-C
Partition Profile

350cm | Length
8,10,12mm | Glass Thickness
Aluminium | Material
Natural Anodize, Satin, Black Anodize | Finish

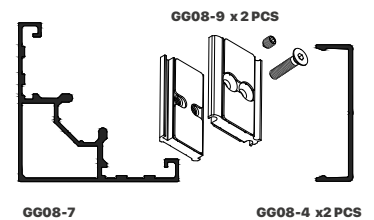
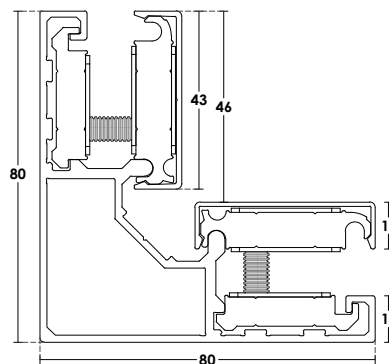

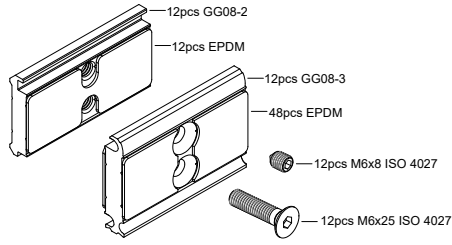

GG08-9

12pcs / SET

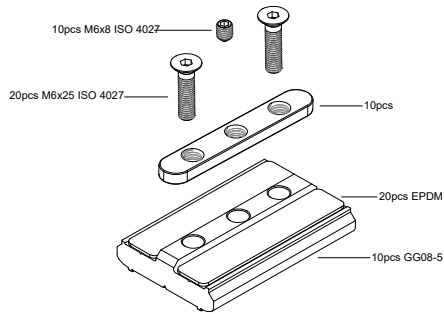

GG08-6U

10pcs / SET

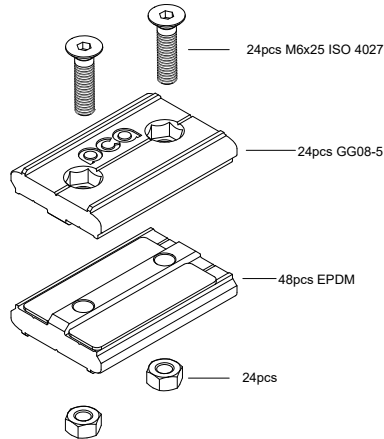

GG08-5

12pcs / SET

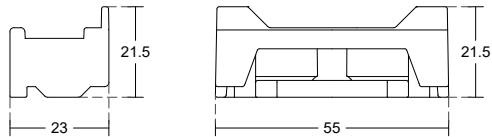

Glass Support | 2PCS / Panel

GG08-8

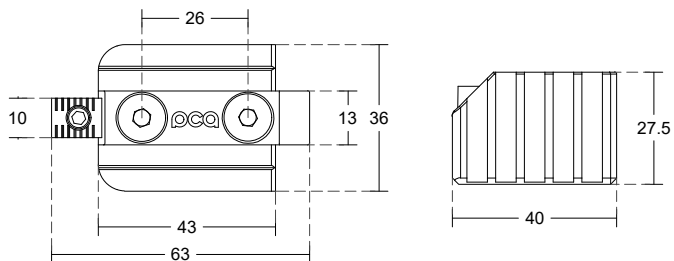

GG08-U Connection

GG08C

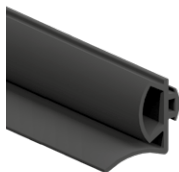

PCA-GTA
Fixing Rubber
60m Roll | Unit
PVC | Material
Grey,White,Black, RAL7015|Finish



10mm

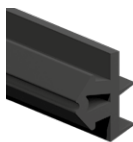

12mm

PCA-GTB
Fixing Rubber
120m Roll | Unit
PVC | Material
10,12mm | Glass Thickness
Grey,White,Black, RAL7015|Finish

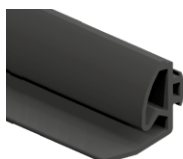

PCA-GTC
Fixing Rubber
60m Roll | Unit
PVC | Material
Grey,White,Black, RAL7015|Finish

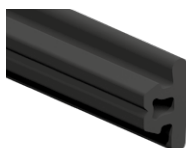

PCA-GTZ
Fixing Rubber
180m Roll | Unit
PVC | Material
Grey,Black|Finish

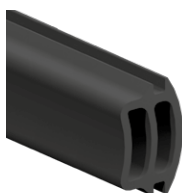

PCA-GTD
GG17 Rubber
30m Roll | Unit
PVC | Material
Black | Finish

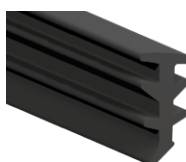

PCA-GG11A
Fixing Rubber
120m Roll | Unit
PVC | Material
Grey,White,Black, RAL7015|Finish

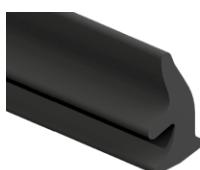

8mm

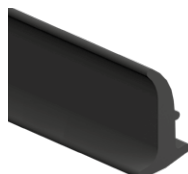

10mm



12mm

PCA-GG11B
Fixing Rubber
120m Roll | Unit
PVC | Material
8,10,12mm | Glass Thickness
Grey,White,Black, RAL7015|Finish



A

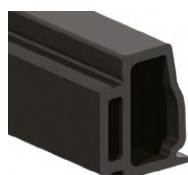

B

PCA-GTQ
Fixing Rubber
60m Roll | Unit
PVC | Material
Grey,White,Black, RAL7015|Finish

NEW

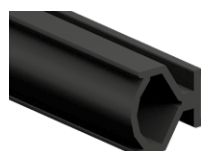

PCA-DGP-AG02
Fixing Rubber
60m Roll | Unit
PVC | Material
Grey,White,Black, RAL7015|Finish

NEW

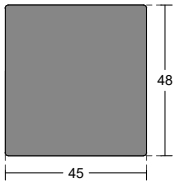

PCA-GG06EC
End Cap
 Stainless Steel | Material
 Natural Anodize, Satin | Finish

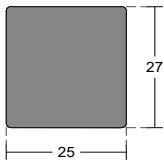

PCA-GG11EC | GG12EC
End Cap
 Stainless Steel | Material
 Natural Anodize, Satin | Finish

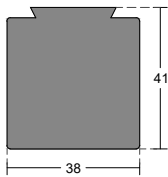

PCA-GT04EC
End Cap
 Stainless Steel | Material
 Natural Anodize, Satin | Finish

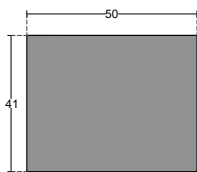

PCA-GT06EC
End Cap
 Stainless Steel | Material
 Natural Anodize, Satin | Finish

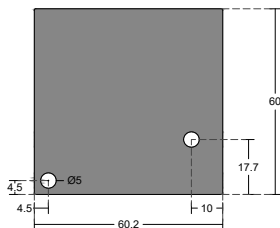

PCA-GT31EC-R | GT31EC-L
End Cap
 Stainless Steel | Material
 Natural Anodize, Satin | Finish

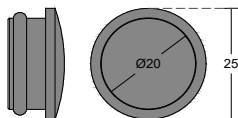

PCA-TC01
GT01 Track End Cap
 Stainless Steel | Material
 Satin | Finish

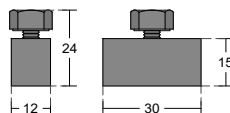

PCA-GG06D
Adjustment Block
 Aluminium | Material
 Mill | Finish

FIXING CORNERS

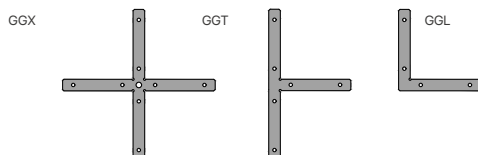

PCA-GGX | PCA-GGT | PCA-GGL
Floor Fixing Corner
 Galvanized Steel | Material

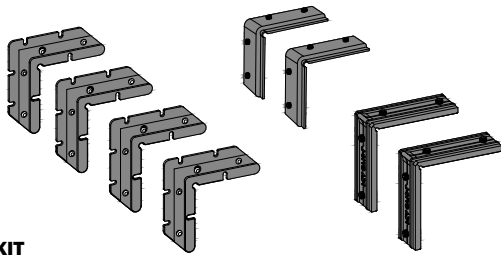

PCA-GT09 KIT
Fixing Corner
Aluminium | Material
Mill | Finish

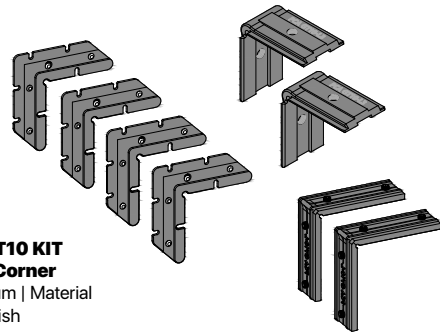

PCA-GT10 KIT
Fixing Corner
Aluminium | Material
Mill | Finish



PCA-GT11 KIT
Fixing Corner
Aluminium | Material
Mill | Material



PCA-GT12 KIT
Fixing Corner
Galvanized Steel , Aluminium | Material
Mill | Material



PCA-GT13 KIT
Fixing Corner
Aluminium | Material
Mill | Finish

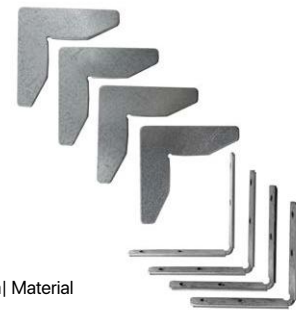

PCA-GG06 KIT
Fixing Corner
Galvanized Steel , Aluminium | Material
Mill | Finish

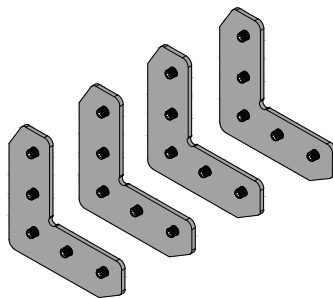

PCA-GG08 KIT
Fixing Corner
Galvanized Steel | Material

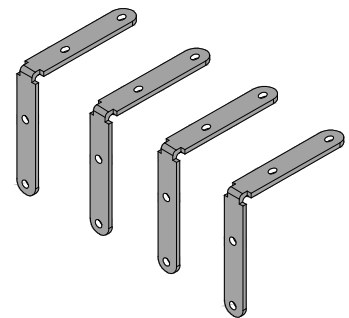

PCA-GG11 KIT
Fixing Corner
Galvanized Steel | Material



PCA-GG12 KIT
Fixing Corner
Galvanized Steel | Material



PCA-GT60 KIT
Fixing Corner
Galvanized Steel | Material

PCA-S31 | S32 | S33 | S34
Clear Joint Strips

320cm | Length
10mm | Glass Thickness
PVC | Material
Extra Clear | Finish



Including Transparent Acrylic Double-Sided Hi-Bond Adhesive Tape

NEW

12mm or 12,76mm
glass thickness

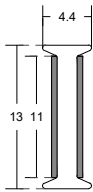

S31-12

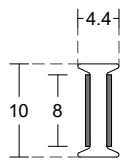

S31

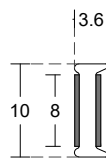

S32

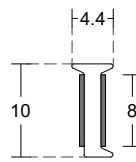

S33

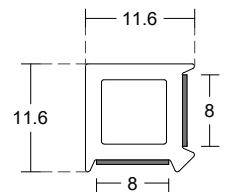

S34

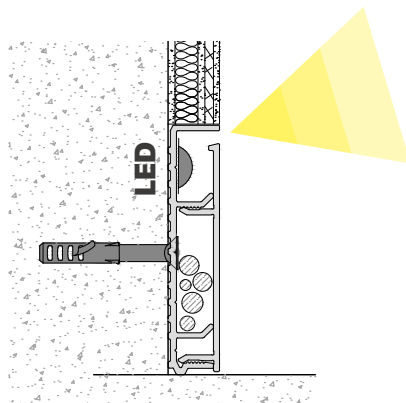
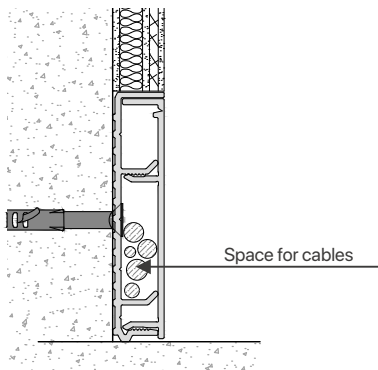
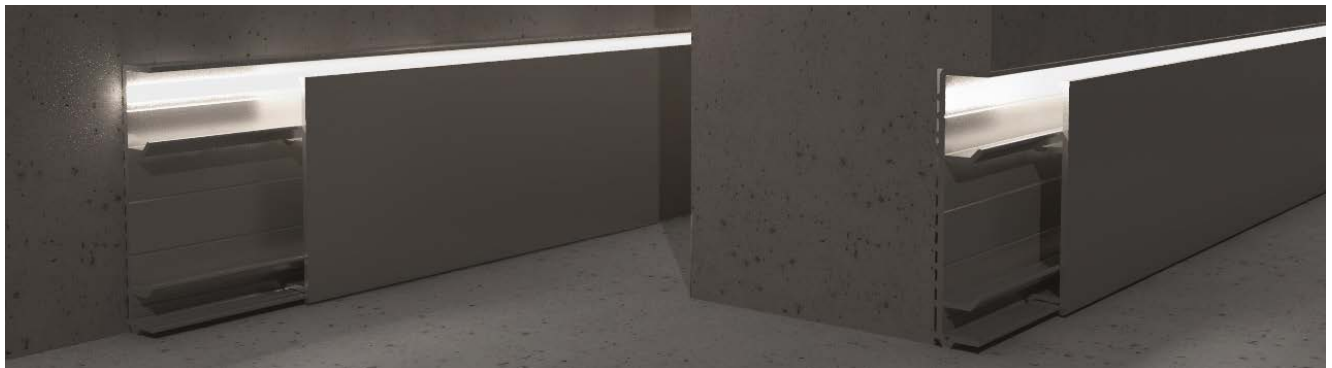

GG16 NESTING BOARD

Nesting Baseboard

Removable Area for LED Installation

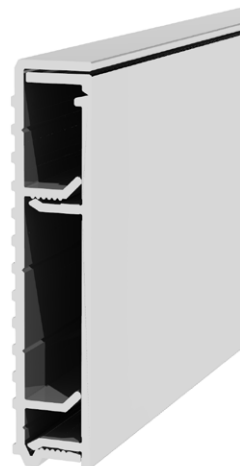
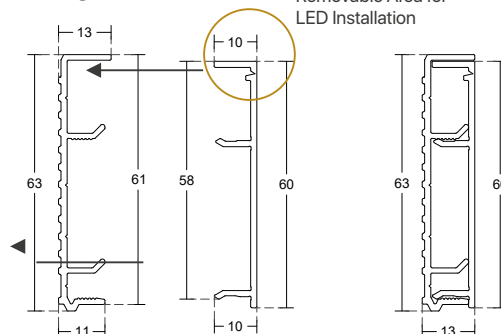

PCA-GG16

Nesting Board

0,947 | Weight/meter
440 cm | Length
Aluminium | Material
Natural Anodize, Satin, Black Anodize | Finish



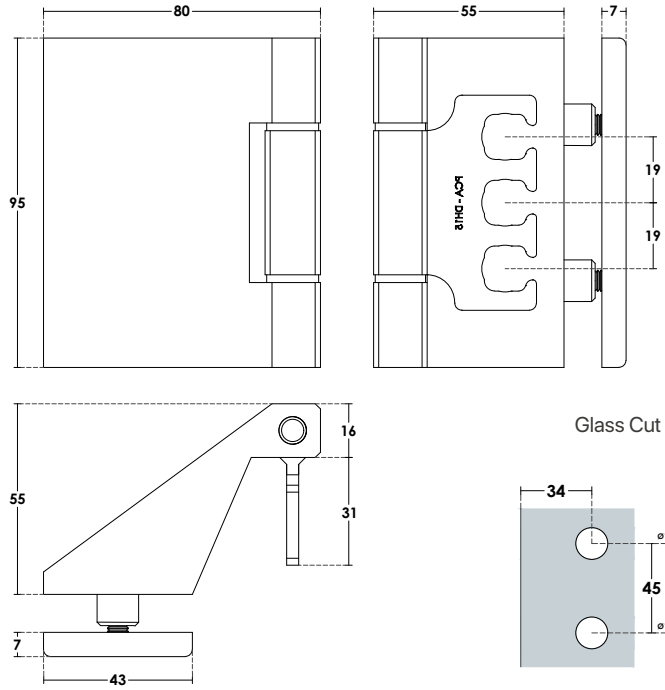



PCA-DH15
3D Door Hinge
 10mm | Glass Thickness
 80 kg | Max. Load
 Aluminium | Material
 Natural Anodize, Satin | Finish

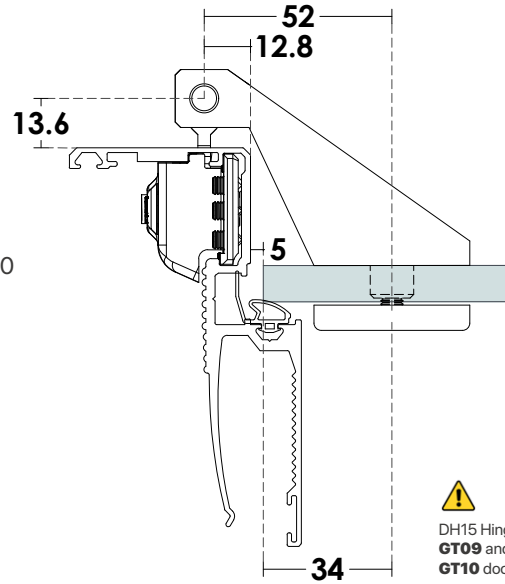

Installation Detail with GT10



 DH15 Hinge only install with **GT09** and **GT10** door frame profiles.

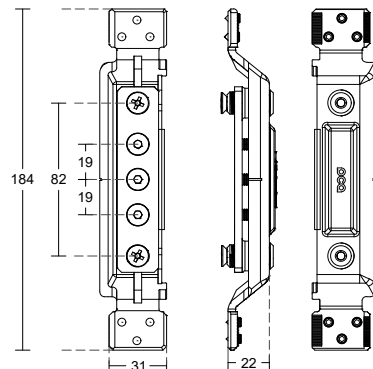

PCA-DH-3D
Door Hinge 3D Adjustment Plate
 Stainless Steel 304 | Material

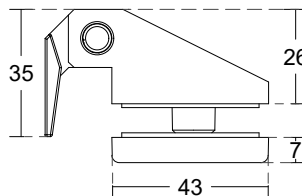
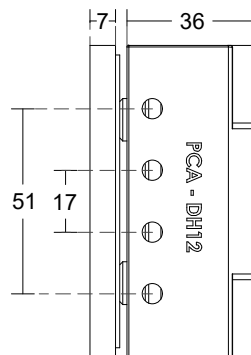
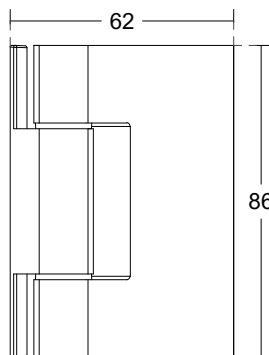

Glass Cut

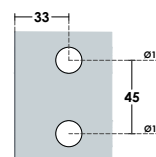

PCA-DH12
Door Hinge
 10mm | Glass Thickness
 50 kg | Max. Load
 Aluminium | Material
 Natural Anodize, Satin, Black | Finish

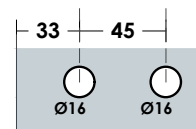
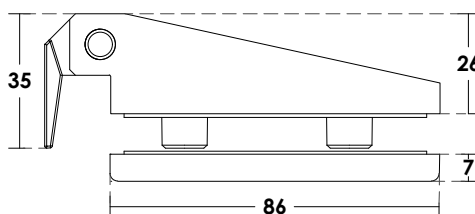
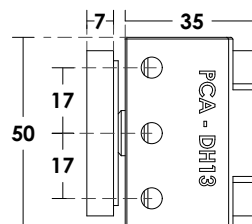
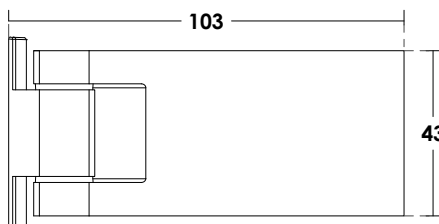

Glass Cut

PCA-DH13
Door Hinge
 10mm | Glass Thickness
 50 kg | Max. Load
 Aluminium | Material
 Natural Anodize, Satin, Black | Finish



! DH12 and DH13 Hinges can be installed with all door frame profiles.

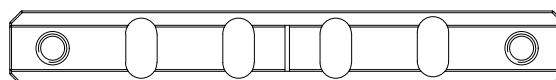
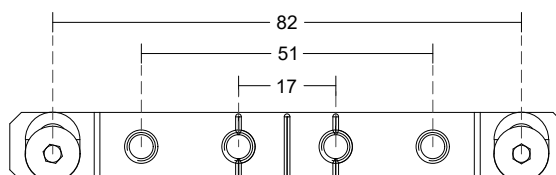
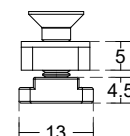

PCA-DH-2D
Door Hinge 2D Adjustment Plate
 Stainless Steel 304 | Material

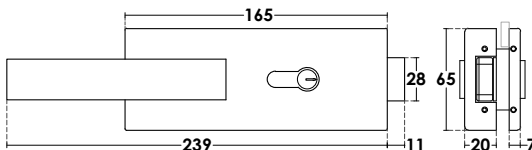

Glass Cut

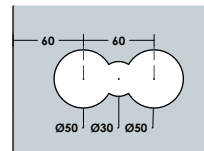

PCA-DL04

Door Lock

10mm | Glass Thickness
Aluminium | Material
Natural Anodize, Satin, Black Anodize | Finish

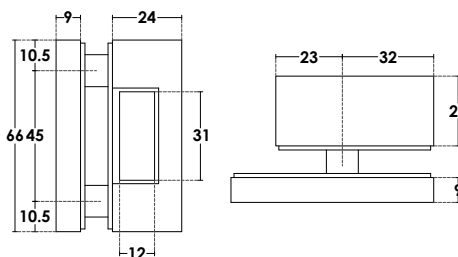

Glass Cut

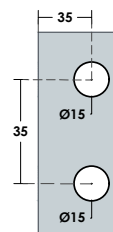

PCA-DL04B

Door Lock Counter Plate

10mm | Glass Thickness
Aluminium | Material
Natural Anodize, Satin, Black Anodize | Finish



CNC machinery required

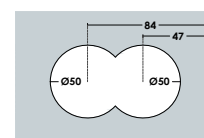
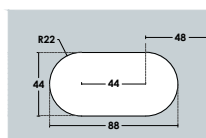

PCA-DL07A

Door Lock

10mm | Glass Thickness
Aluminium | Material
Natural Anodize, Satin | Finish

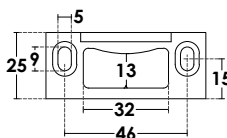
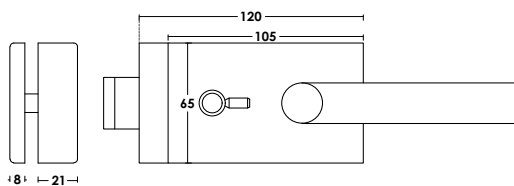

PCA-DL09A

DL04 Strike Plate

Aluminium | Material
Natural Anodize, Satin, Black Anodize | Finish



6mm glass
S35 polycarbonate

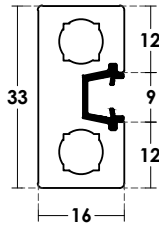

8mm glass
No polycarbonate

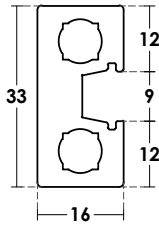

PCA-GT14

Door Frame Track

0,947 | Weight/meter
580 cm | Length
6-8mm | Glass Thickness
Aluminium | Material
Natural Anodize, Satin, Black Anodize | Finish



PRODUCT LIST

NEW

8mm glass
S38 polycarbonate

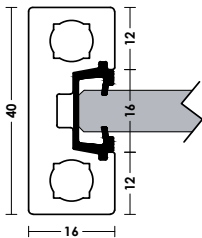

10mm glass
S38 polycarbonate

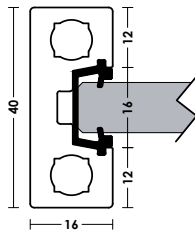

12mm glass
S38 polycarbonate

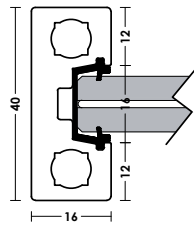

PCA-GT24

Door Frame Track

1,049 | Weight/meter
580 cm | Length
8-12mm | Glass Thickness
Aluminium | Material
Natural Anodize, Satin, Black Anodize | Finish



PCA-GT14A KIT

KIT For GT09,GT10 Door Frame

Stainless Steel | Material

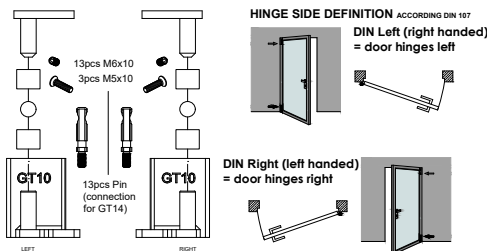

PCA-GT14B KIT

KIT For GT11, GT12, GT13 Door Frame

Stainless Steel | Material

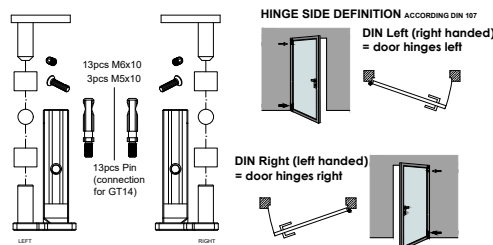

Door Lock for GT14



**PCA-GT14-DL
GT14 Door Lock**

6mm | Glass Thickness
Aluminium | Material
Natural Anodize, Satin, Black Anodize | Finish

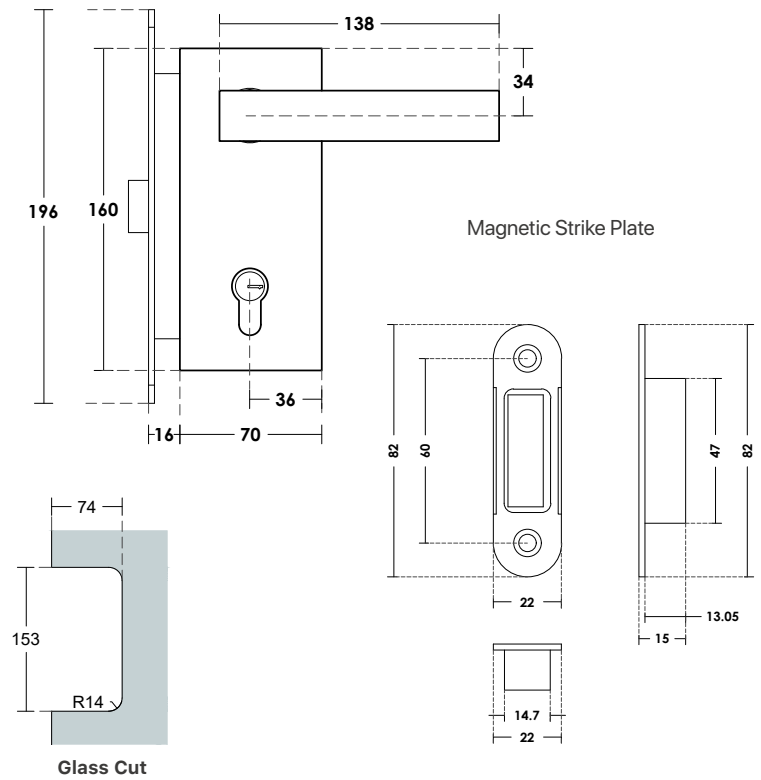

Glass Cut



Magnetic Strike Plate

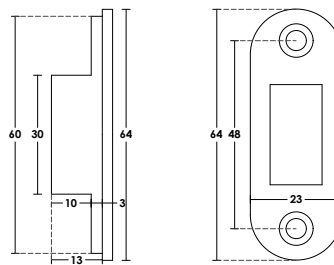

Glass Cut

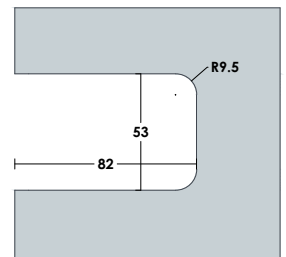

Door Lock for GT14

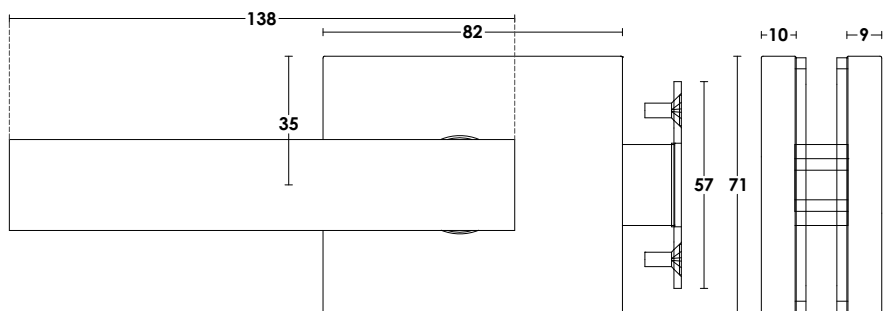

**PCA-GT14-DL2
Door Lock**

6mm | Glass Thickness
Aluminium | Material
Natural Anodize, Satin, Black | Finish



NEW



GT14-BL Bolt



6mm glass
S35 polycarbonate

8mm glass
No polycarbonate

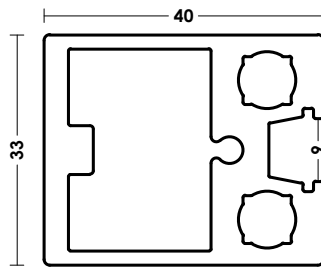
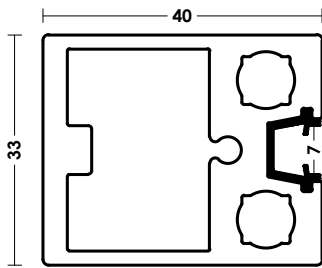

PCA-GT14-2
GT14 frame for double door
1,490 | Weight/meter
350 cm | Length
6-8 mm | Glass Thickness
Aluminium | Material
Natural Anodize, Satin, Black Anodize | Finish



PRODUCT LIST



PCA-LH01
Aluminium | Material
Natural Anodize, Satin, Black Anodize | Finish

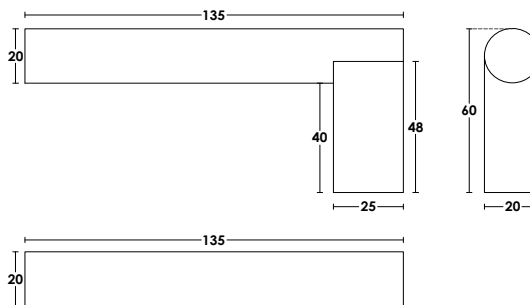

NEW



PCA-LH02
Aluminium | Material
Natural Anodize, Satin, Black Anodize | Finish

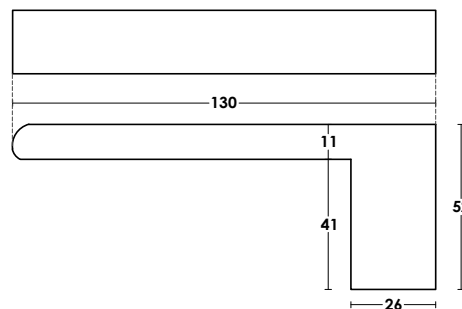

NEW

The handles are suitable on **GT14DL2, GT24DL, GT24DL2, GT24DL3** and **DL04** door locks.

NEW

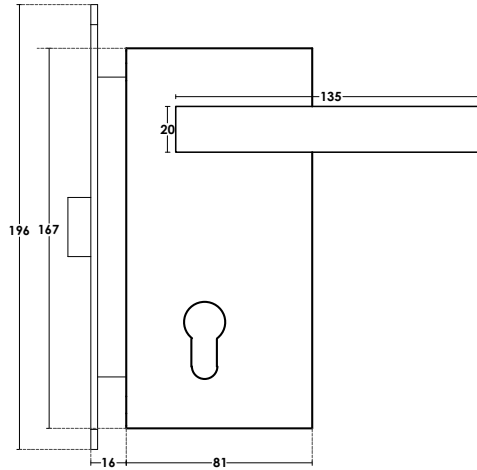

PCA-GT24-DL
GT24 Door Magnet Lock
8-12mm | Glass Thickness
Aluminium | Material
Natural Anodize, Satin, Black Anodize | Finish



NEW

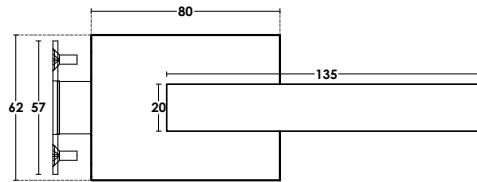

PCA-GT24-DL2
GT24 Door Handle
8-12mm | Glass Thickness
Aluminium | Material
Natural Anodize, Satin, Black Anodize | Finish



NEW

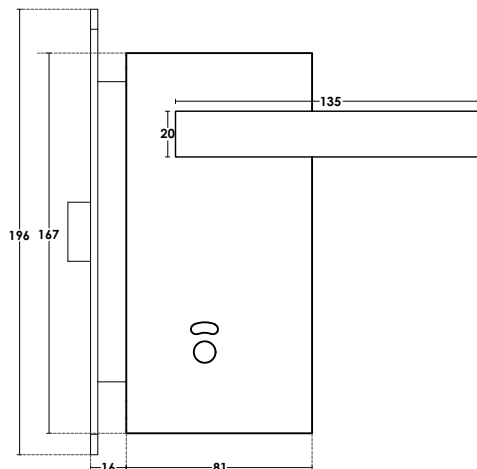

PCA-GT24-DL3
GT24 WC Door Magnet Lock
8-12mm | Glass Thickness
Aluminium | Material
Natural Anodize, Satin, Black Anodize | Finish



CROSS PROFILES

NEW

PCA-GT16-1

Cross Profile

350cm | Length

Aluminium | Material

Natural Anodize, Satin, Black Anodize | Finish

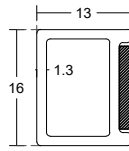

OPTIONAL
TESA TAPE



PCA-GT16-2

Cross Profile

350cm | Length

Aluminium | Material

Natural Anodize, Satin, Black Anodize | Finish

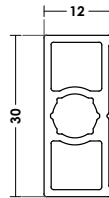

OPTIONAL
TESA TAPE



PCA-GT16-4

Cross Profile

580cm | Length

Aluminium | Material

Natural Anodize, Satin, Black | Finish

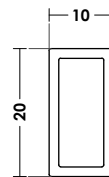

OPTIONAL
TESA TAPE



NEW

PCA-GT16-5

Cross Profile

580cm | Length

Aluminium | Material

Natural Anodize, Satin, Black | Finish

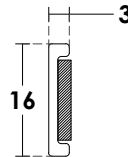

OPTIONAL
TESA TAPE

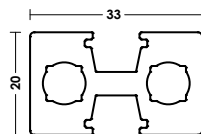

PCA-GT14-H

Cross Profile

580cm | Length

Aluminium | Material

Natural Anodize, Satin, Black | Finish

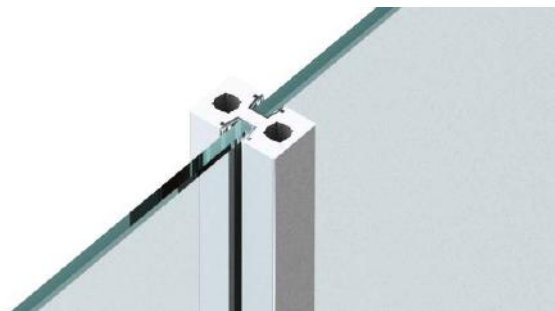

NEW

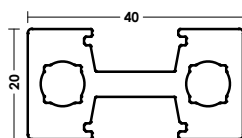

PCA-GT24-H

Cross Profile

580cm | Length

Aluminium | Material

Natural Anodize, Satin, Black | Finish

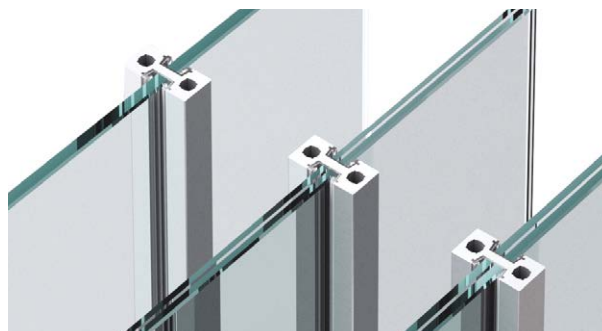

NEW

NEW



8mm glass
S38 polycarbonate

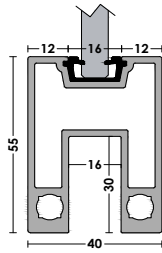

10mm glass
S38 polycarbonate

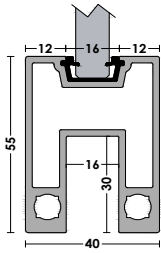

12mm glass
S38 polycarbonate

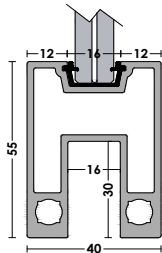

PCA-GT34

Door Frame Track

1,631 | Weight/meter
350 cm | Length
8-12mm | Glass Thickness
Aluminium | Material
Natural Anodize, Satin, Black Anodize | Finish



Compatible with **drop seal WB02** and **door closer DC03**.

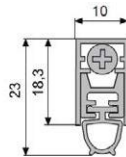

PCA-WB01

Drop Seal

100cm | Length
Aluminium/EPDM | Material

NEW

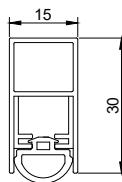

PCA-WB02
Drop Seal (GT34)

100cm | Length
Aluminium/EPDM | Material

NEW

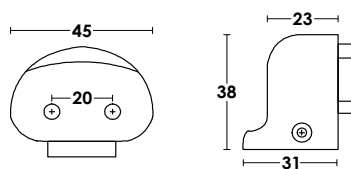

PCA-SP16

Floor Stop

Stainless Steel 304 | Material
Satin | Finish

NEW

Shower Cabins & WC Partitions	8
Doors & Office Partitions	81
Facades	169
Folding	199
Guillotine	209
Spiders	215
Balcony Railings	225
Inox Railings	273
Staircase	293
Canopies	297
Miscellaneous & Consumables	307

WR1 |

FACADES SERIES



TYPOLOGIES

FAÇADES

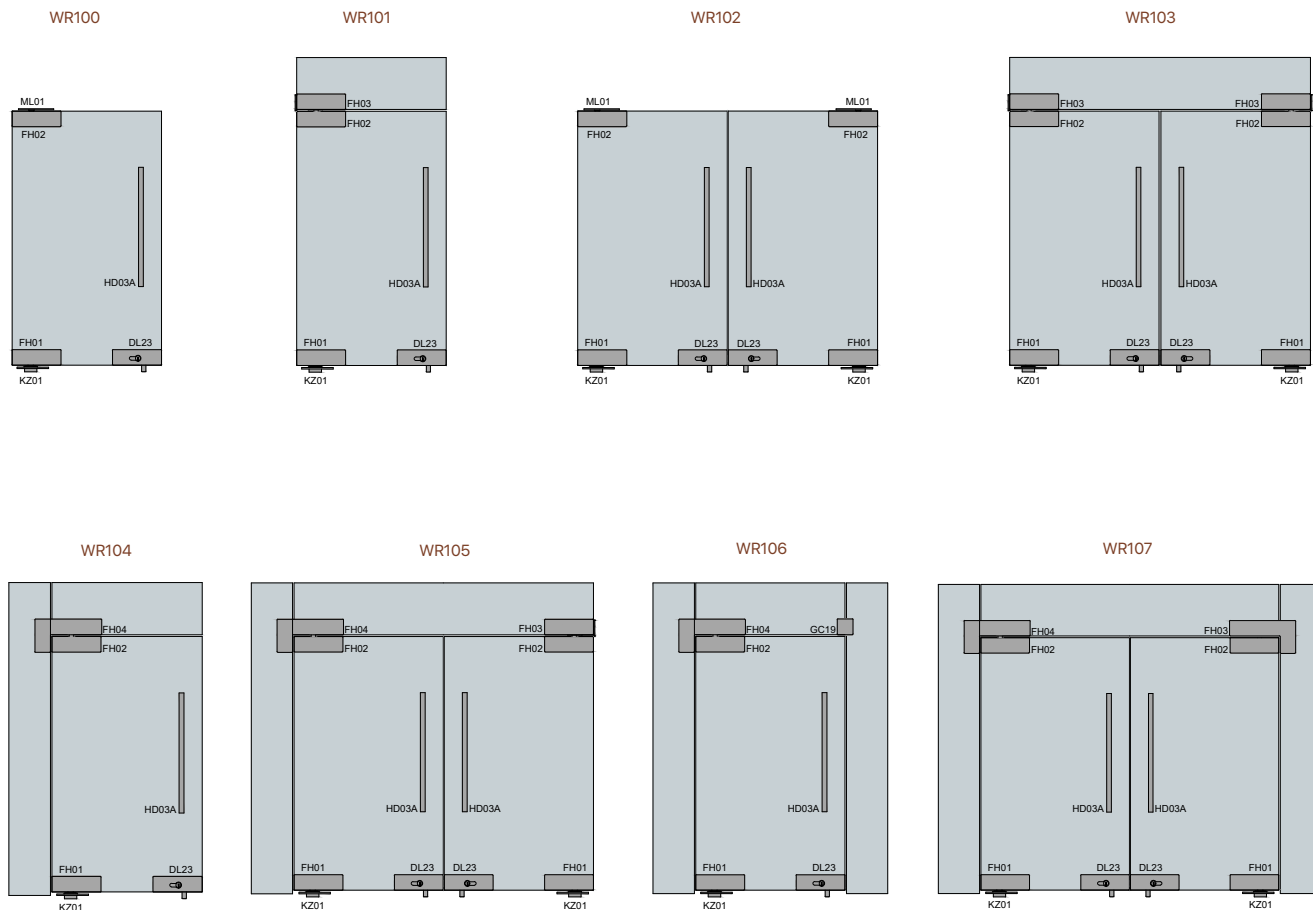

DESCRIPTION:
 -Material SS304 Satin
 -Fit for 10 - 12mm tempered glass

WR2

FACADES SERIES



TYPOLOGIES

FAÇADES

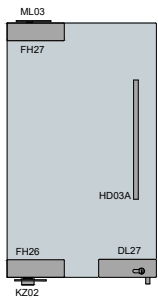

WR200

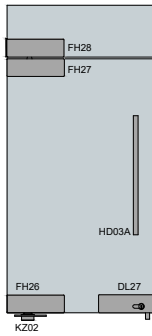

WR201

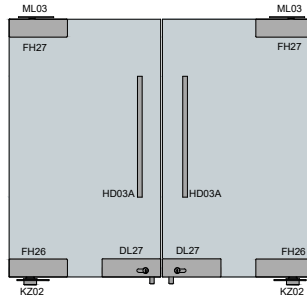

WR202

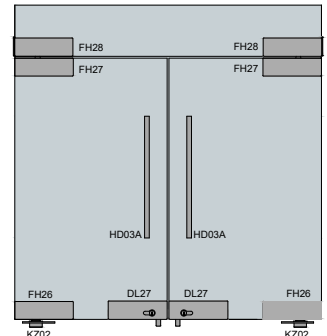

WR203

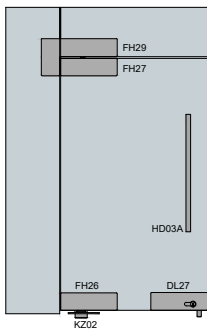

WR204

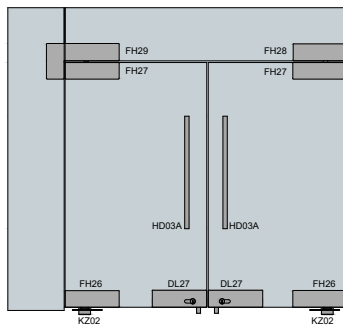

WR205

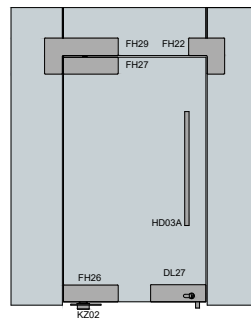

WR206

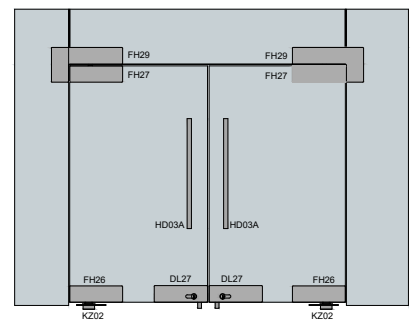

WR207



FH26



FH27



ML03



KZ02



DL27



FH28



FH29



FH22



HD03A
(Optional)

DESCRIPTION:
-Material SS304 Satin
-Fit for 10 - 12mm tempered glass

WS1 |

FACADES SERIES



TYPES

FAÇADES

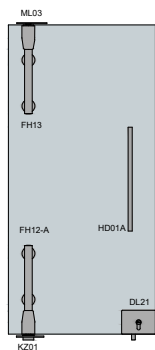

WS100

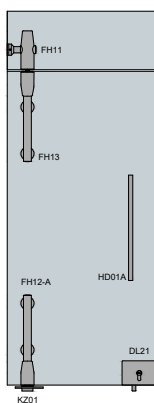

WS101

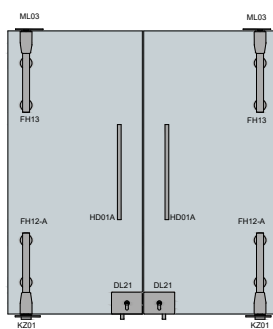

WS102

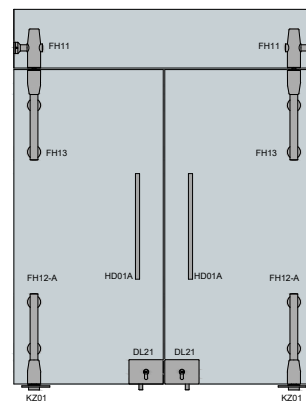

WS103

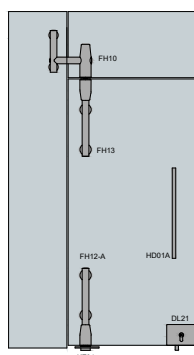

WS104

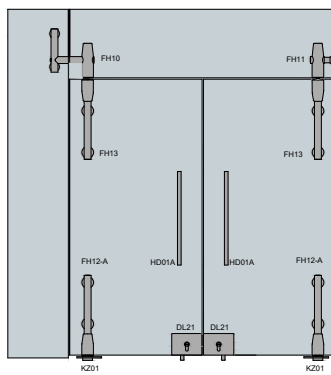

WS105

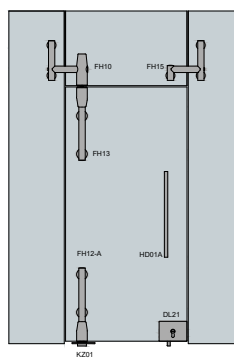

WS106

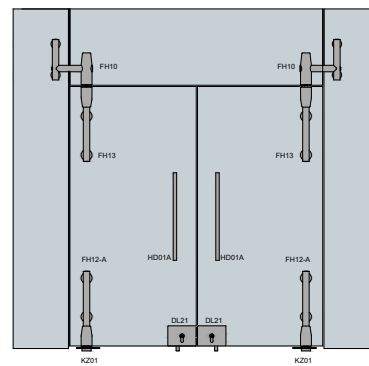

WS107



FH12-A



FH13



ML03



KZ01



DL21



FH11



FH10



FH15



HD01A
(Optional)

DESCRIPTION:
-Material SS304 Satin
-Fit for 10 - 12mm tempered glass



ML03

FH30 Top

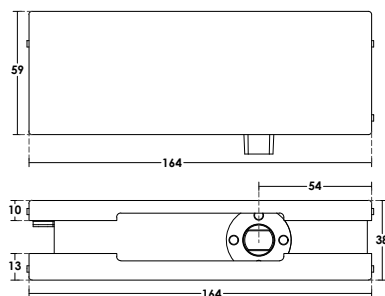

FH30 Bottom

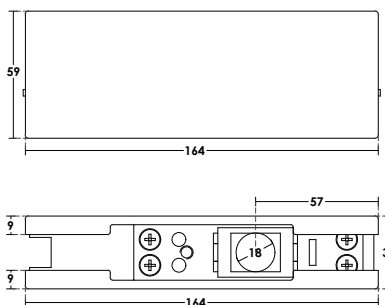

PCA-FH30
Facade Top & Bottom Fitting SET
 8-12mm | Glass Thickness
 60 kg | Max. Weight
 Stainless Steel 304 | Material
 Satin | Finish

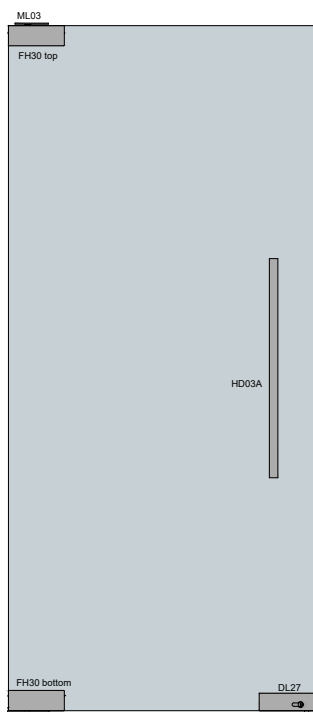

1 x FH30 SET
top & bottom



1 x ML03



1 x DL27



1 x HD03A
 (Optional)

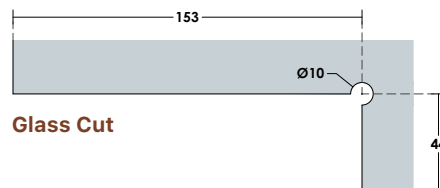
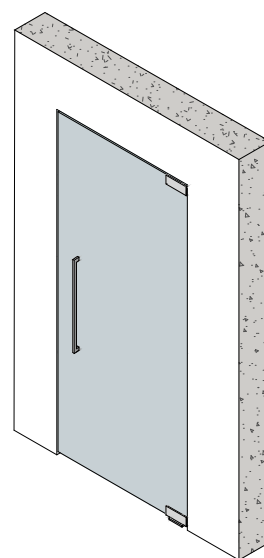

Glass Cut

- DESCRIPTION:**
- Material SS304 Satin
 - Fit for 8-12mm tempered glass
 - Max width 1000mm, Max weight capacity 60 kg
 - 4° alignment adjustment
 - Max open at 150 degree, hold open at 90 degree
 - 1,6 cm adjustment
 - Durability 500.000 cycles testing

NEW

HYDRAULIC GLASS DOOR HINGE



FAÇADES

PCA-FH31

Hydraulic Hinge

8-14mm | Glass Thickness
 100 kg | Max. Door Weight
 95° double action | Max. Opening Angle
 240cm | Max. Door Height
 100cm | Max. Door Width
 Stainless Steel | Material
 Satin | Finish

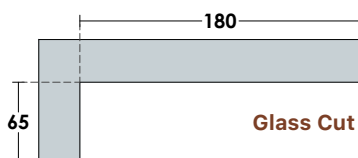
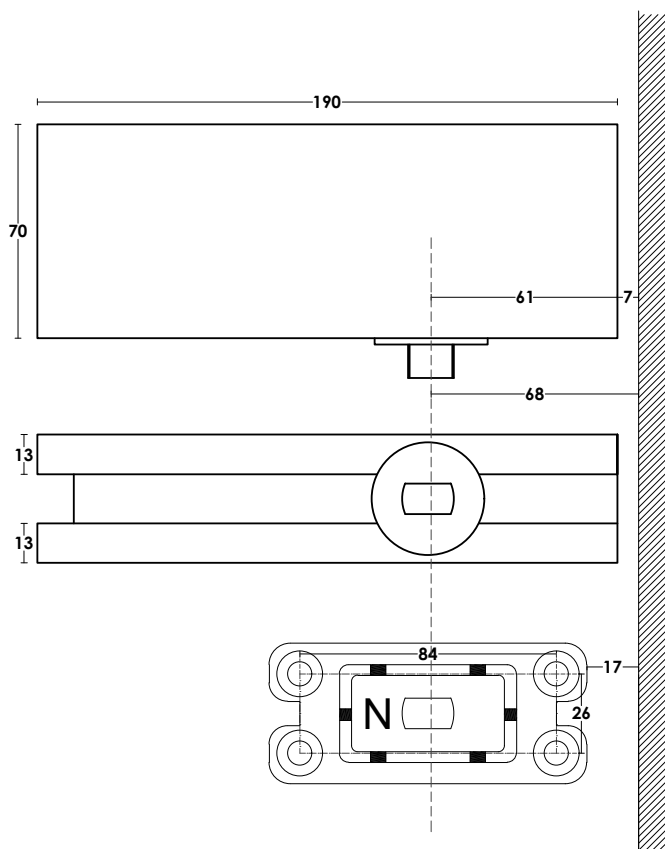

-Compatible with upper patch **FH02** or **FH27**

DESCRIPTION:

- Material SS304 Satin
- Fit for 8-14mm tempered glass
- Max width 1000mm, Max weight capacity 100 kg
- Two speed adjustment
- Max open at 150 degree, hold open at 90 degree
- Durability 500.000 cycles testing

W1 |

FACADE SERIES

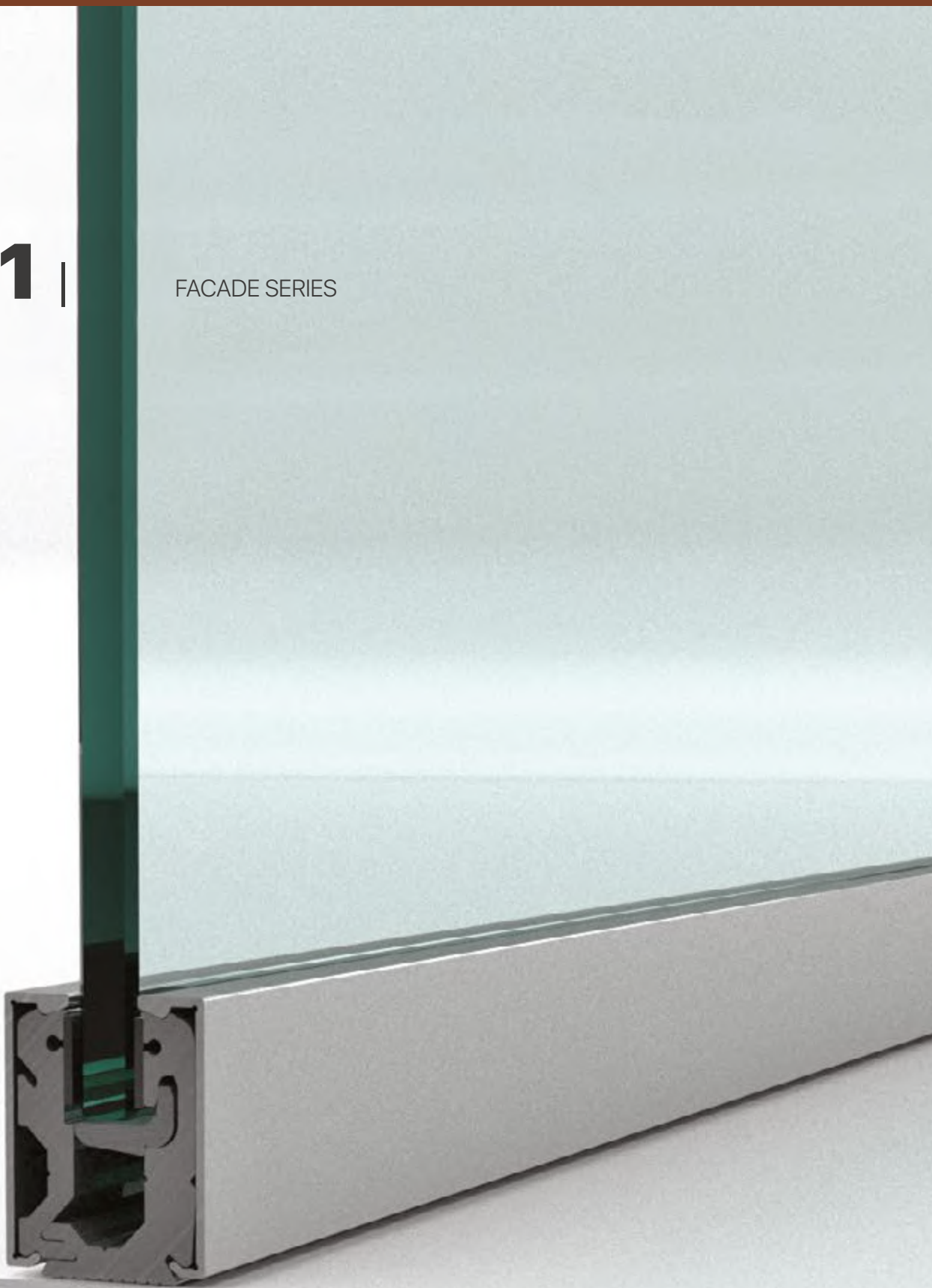

GG07

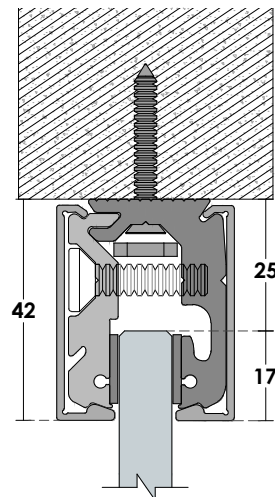
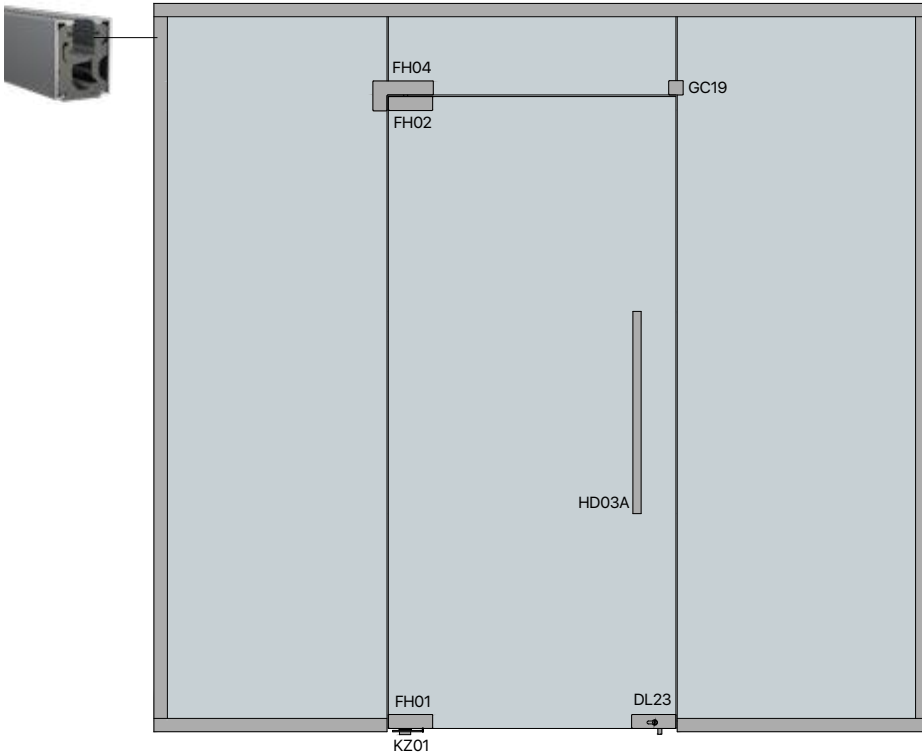

FAÇADES

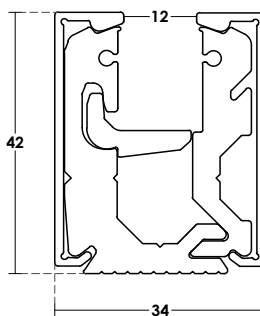

**PCA-GG07
Partition Profile**

580 cm | Length
10-12mm | Glass Thickness
1,747kg | Weight/meter
Aluminium | Material
Natural Anodize, Satin | Finish



W2 |

FACADE SERIES

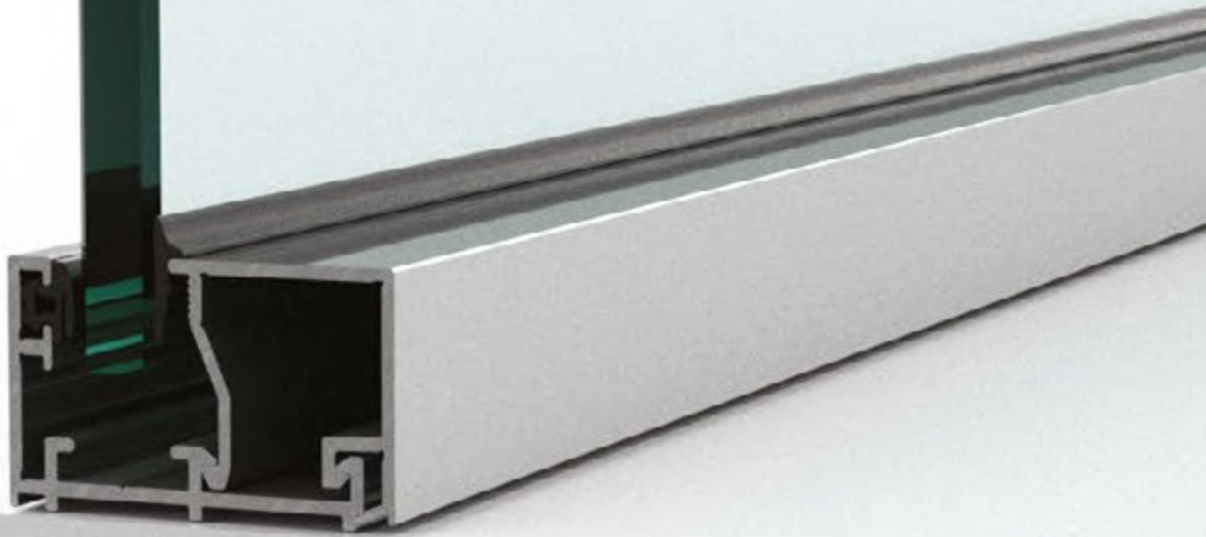

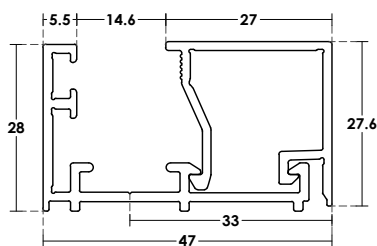
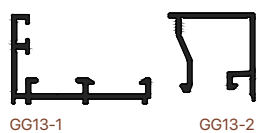
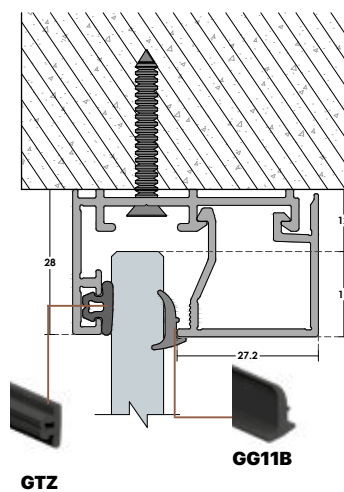
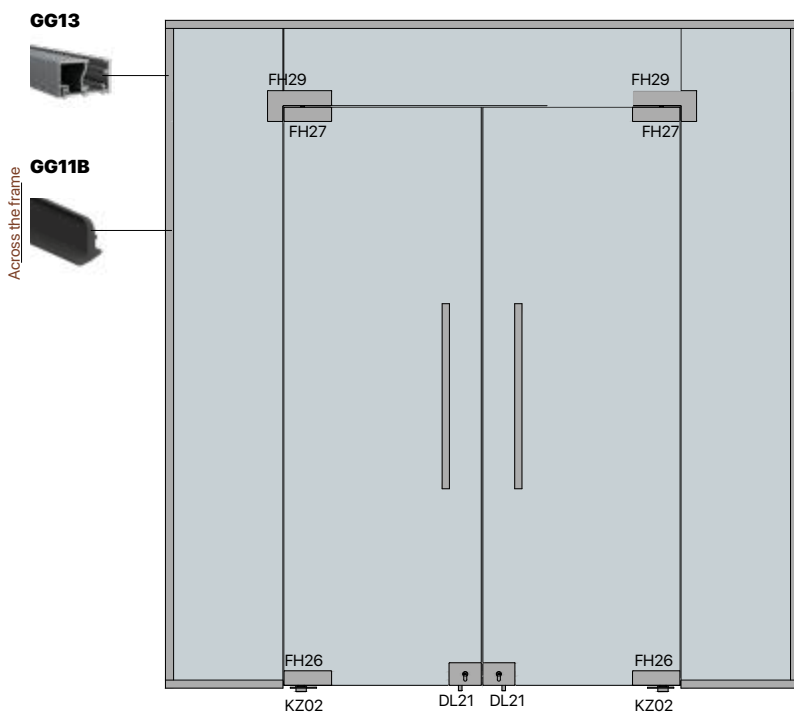

PCA-GG13
Partition Profile
 580 cm | Length
 10-12mm | Glass Thickness
 0,806kg | Weight/meter
 Aluminium | Material
 Natural Anodize, Satin | Finish



With regular arm and fire oil

PCA-DC01
Door Closer Mechanism
80 kg | Max. Weight
Stainless Steel 304 | Material
Natural Anodize | Finish



With sliding arm

PCA-DC02
Door Closer Mechanism
80 kg | Max. Weight
Stainless Steel 304 | Material
Natural Anodize | Finish



With sliding arm

PCA-DC03
Concealed Door Closer
80 kg | Max. Weight
Stainless Steel 304 | Material
Natural Anodize | Finish

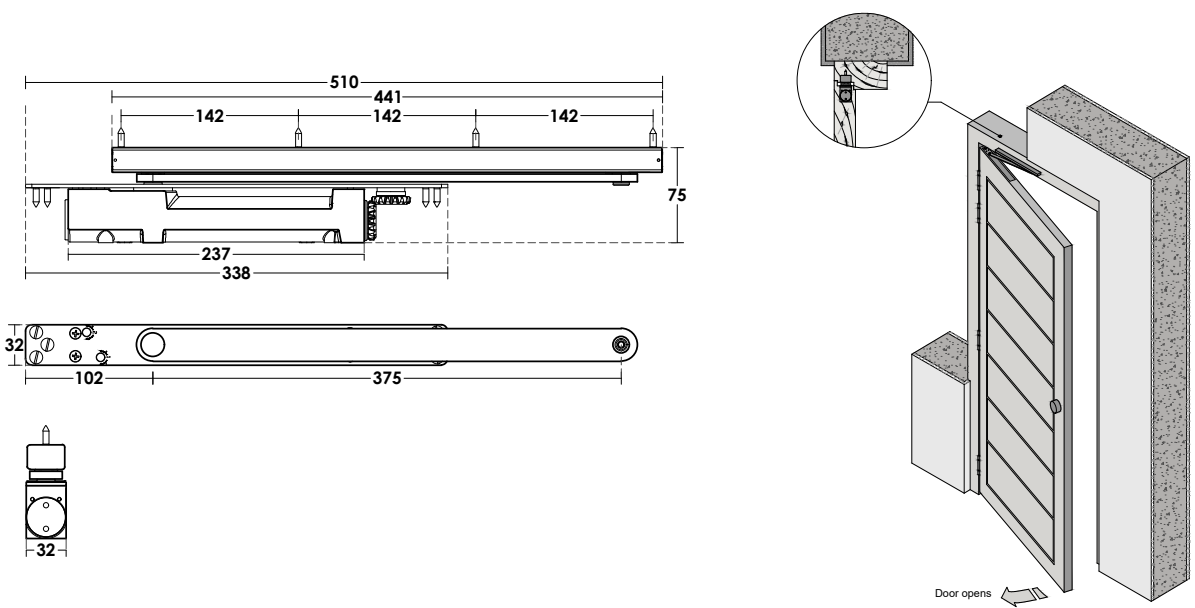
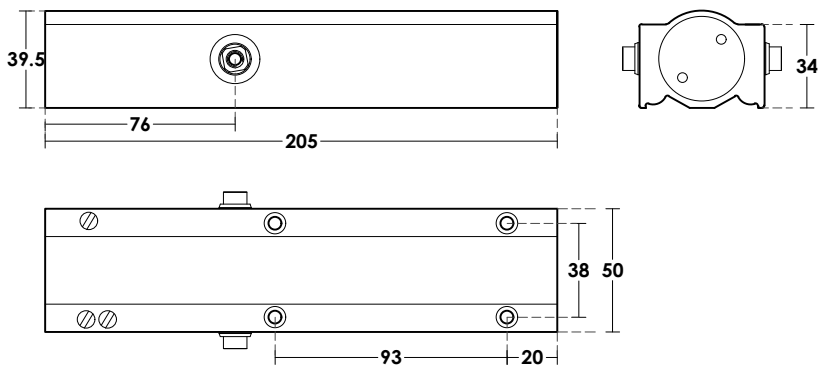
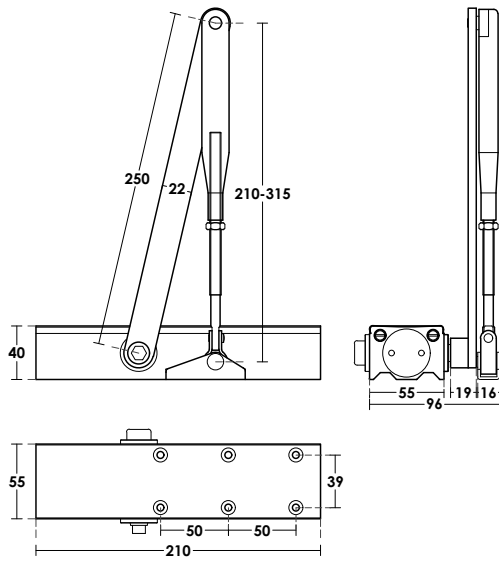



PCA-FH01
Facade Bottom Fitting
 10-12mm | Glass Thickness
 60 kg | Max. Weight
 Aluminium, Stainless Steel 304 | Material
 Natural Anodize, Satin | Finish

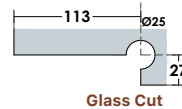
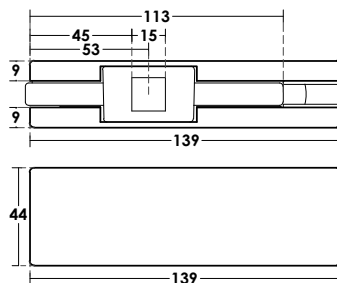

Glass Cut



PCA-FH02
Facade Top Fitting
 10-12mm | Glass Thickness
 Aluminium, Stainless Steel 304 | Material
 Natural Anodize, Satin | Finish

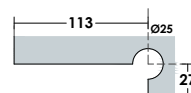
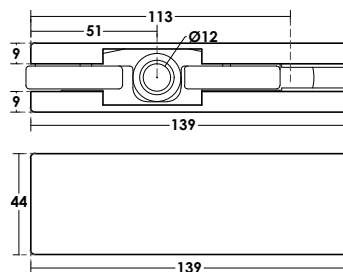

Glass Cut



PCA-FH03
Facade Top Fitting
 10-12mm | Glass Thickness
 Aluminium, Stainless Steel 304 | Material
 Natural Anodize, Satin | Finish

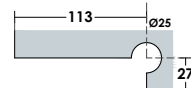
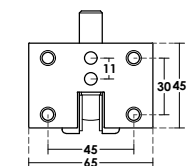
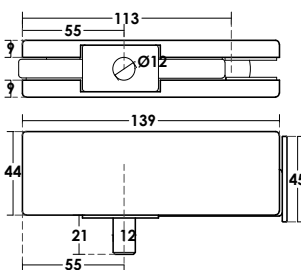

Glass Cut



PCA-FH04
Facade Top Fitting
 10-12mm | Glass Thickness
 Aluminium, Stainless Steel 304 | Material
 Natural Anodize, Satin | Finish

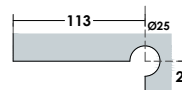
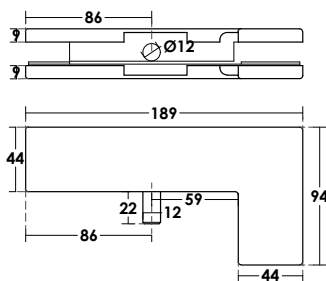

Glass Cut



PCA-FH04A
Facade Top Fitting
 10-12mm | Glass Thickness
 Aluminium | Material
 Natural Anodize, Satin | Finish

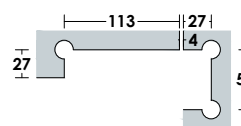
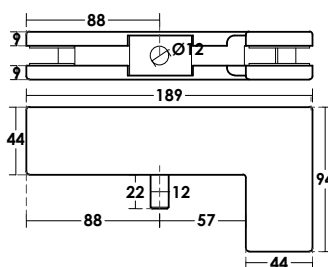

Glass Cut

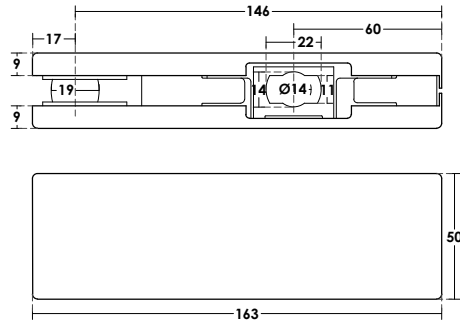
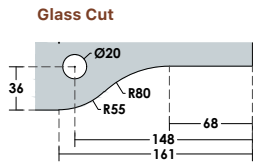

PCA-FH26
Facade Bottom Fitting
 10-12mm | Glass Thickness
 80 kg | Max. Weight
 Aluminium, Stainless Steel 304 | Material
 Natural Anodize, Satin | Finish

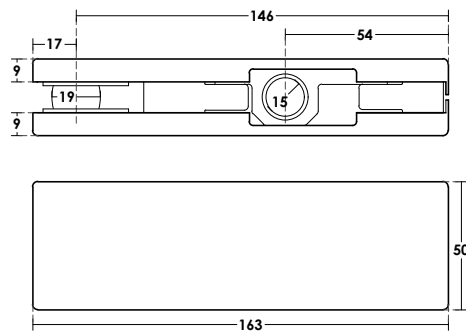
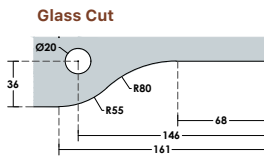

PCA-FH27
Facade Top Fitting
 10-12mm | Glass Thickness
 Aluminium, Stainless Steel 304 | Material
 Natural Anodize, Satin | Finish

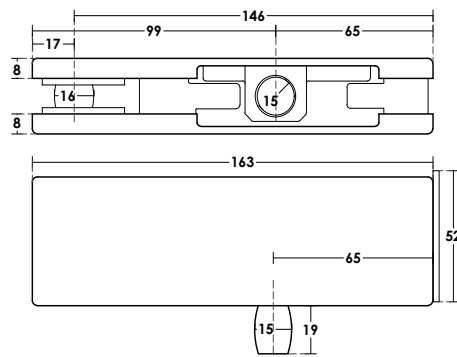
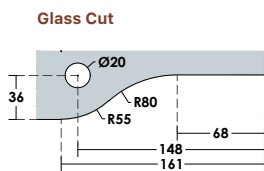
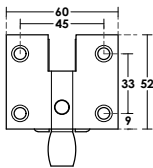

PCA-FH28
Facade Top Fitting
 10-12mm | Glass Thickness
 Aluminium, Stainless Steel 304 | Material
 Natural Anodize, Satin | Finish

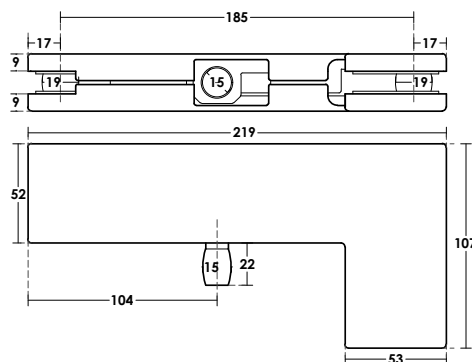
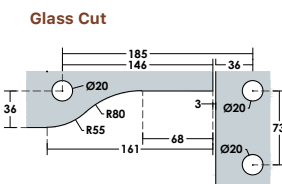

PCA-FH29
Facade Top Fitting
 10-12mm | Glass Thickness
 Aluminium, Stainless Steel 304 | Material
 Natural Anodize, Satin | Finish



PCA-DL21
Door Lock

10-12mm | Glass Thickness
Aluminium, Stainless Steel 304 | Material
Natural Anodize, Satin | Finish

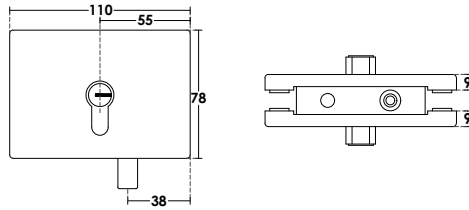

Glass Cut

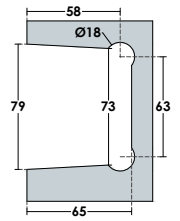

PCA-DL23
Door Lock

10-12mm | Glass Thickness
Aluminium | Material
Natural Anodize | Finish

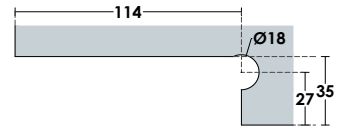
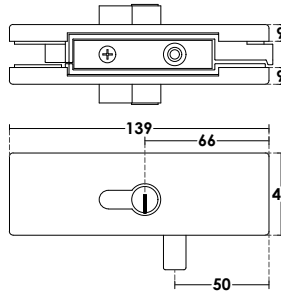

Glass Cut



PCA-DL27
Door Lock

10-12mm | Glass Thickness
Aluminium, Stainless Steel 304 | Material
Natural Anodize, Satin | Finish

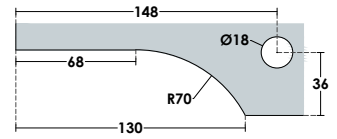
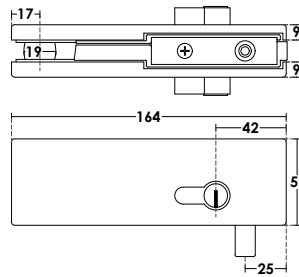

Glass Cut

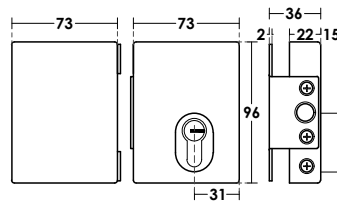

PCA-DL25
Additional Door Lock

10-12mm | Glass Thickness
Stainless Steel 304 | Material
Satin | Finish

MAGNETIC PIN

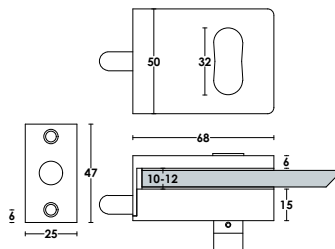

Glass Cut

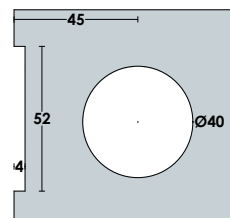

PCA-BL12
Magnetic Door Lock

10-12mm | Glass Thickness
Stainless Steel 304 | Material
Satin | Finish

MAGNETIC PIN

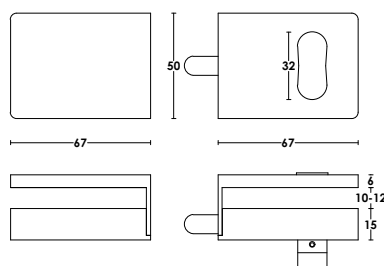

Glass Cut

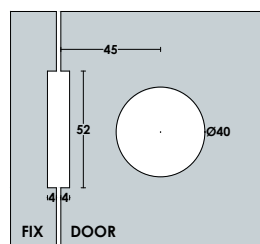

PCA-BL13
Magnetic Door Lock

10-12mm | Glass Thickness
Stainless Steel 304 | Material
Satin | Finish

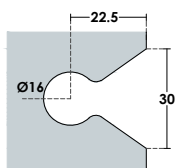

Glass Cut

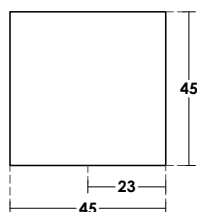
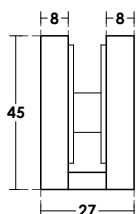

PCA-GC18
Glass - Wall Clamp
 25 kg | Max. Weight
 10-12mm | Glass Thickness
 Aluminium | Material
 Natural Anodize | Finish

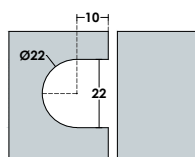

Glass Cut

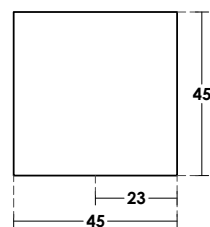
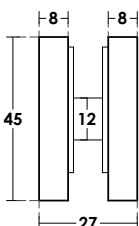

PCA-GC19
Glass - Glass Clamp
 25 kg | Max. Weight
 10-12mm | Glass Thickness
 Aluminium | Material
 Natural Anodize | Finish

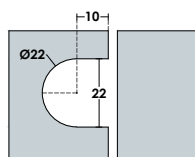

Glass Cut

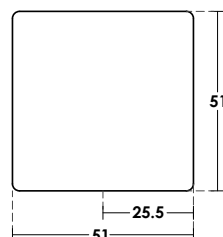
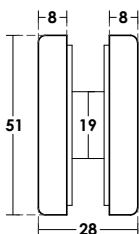

PCA-GC19B
Glass - Glass Clamp
 25 kg | Max. Weight
 10-12mm | Glass Thickness
 Stainless Steel 304 | Material
 Satin | Finish

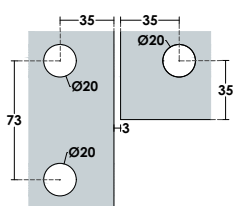

Glass Cut

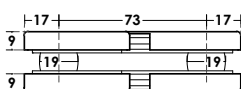
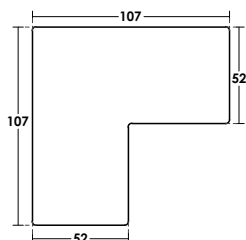

PCA-FH22
Glass - Glass Fitting
 25 kg | Max. Weight
 10-12mm | Glass Thickness
 Aluminium, Stainless Steel 304 | Material
 Natural Anodize, Satin | Finish



PCA-KP01
Floor Socket
 Stainless Steel 304 | Material
 Satin | Finish

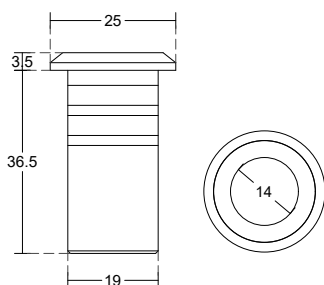

PCA-KP03
Floor Socket
 Stainless Steel 304 | Material
 Satin | Finish

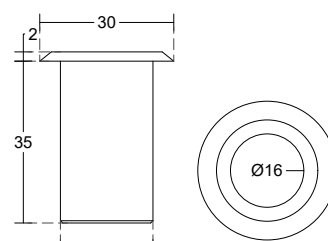



PCA-FC06
90° Glass - Glass Clamp
 10-12mm | Glass Thickness
 40 kg | Max. Weight
 Stainless Steel 304 | Material
 Satin | Finish

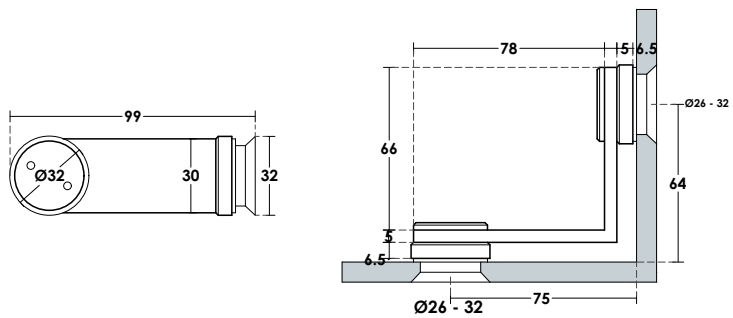

PCA-FC07
90° Glass - Wall Clamp
 10-12mm | Glass Thickness
 40 kg | Max. Weight
 Stainless Steel 304 | Material
 Satin | Finish

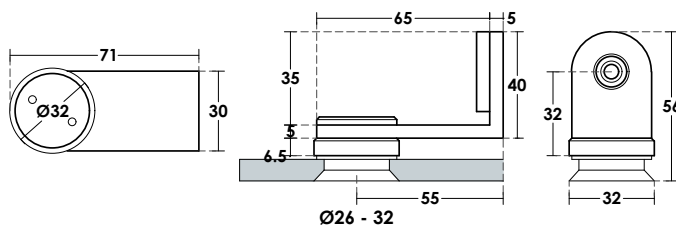

PCA-FC08
Glass - Glass Clamp
 10-12mm | Glass Thickness
 40 kg | Max. Weight
 Stainless Steel 304 | Material
 Satin | Finish

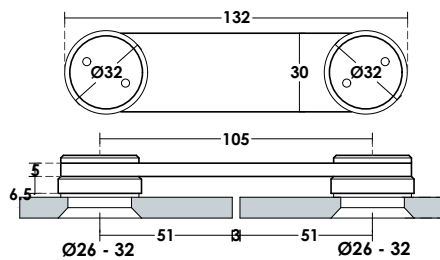

PCA-SP11
Stop
 10-12mm | Glass Thickness
 Stainless Steel 304 | Material
 Satin | Finish

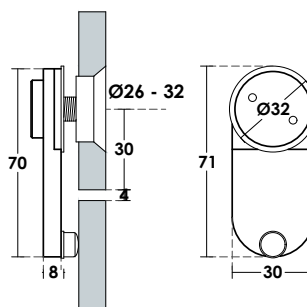

PCA-SP12
Stop
 Stainless Steel 304 | Material
 Satin | Finish

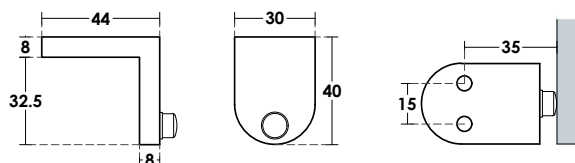

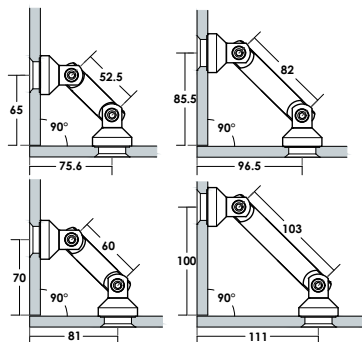

Ø 26-32 Glass Hole

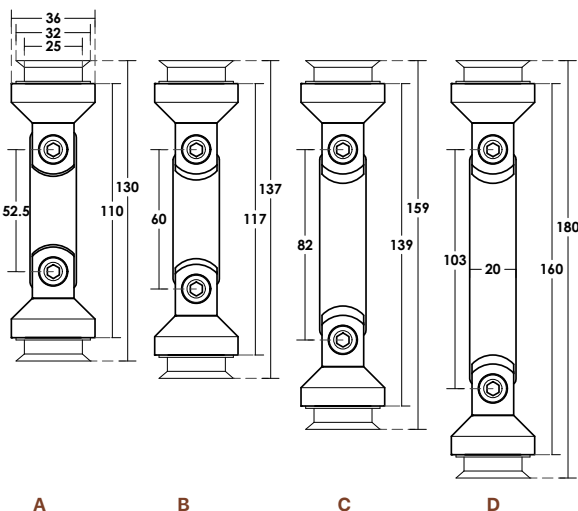

PCA-FC01
Facade Glass - Glass Clamp
 10-12mm | Glass Thickness
 50 kg | Max. Weight
 Stainless Steel 304 | Material
 Satin | Finish

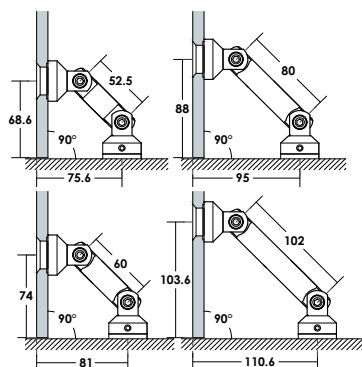

Ø 26-32 Glass Hole

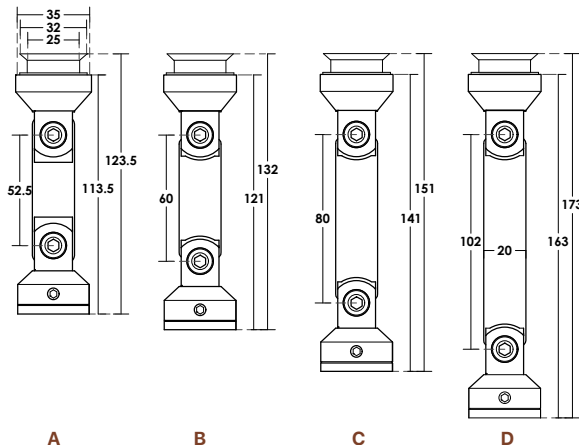

PCA-FC02
Facade Wall - Glass Clamp
 10-12mm | Glass Thickness
 50 kg | Max. Weight
 Stainless Steel 304 | Material
 Satin | Finish

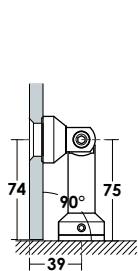

Ø 26-32 Glass Hole

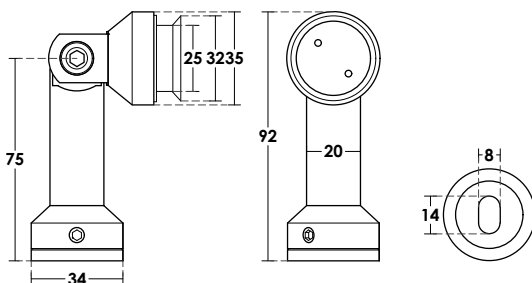

PCA-FC03
Facade Wall - Glass Clamp
 10-12mm | Glass Thickness
 50 kg | Max. Weight
 Stainless Steel 304 | Material
 Satin | Finish

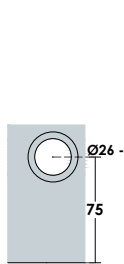

Ø 26-32 Glass Hole

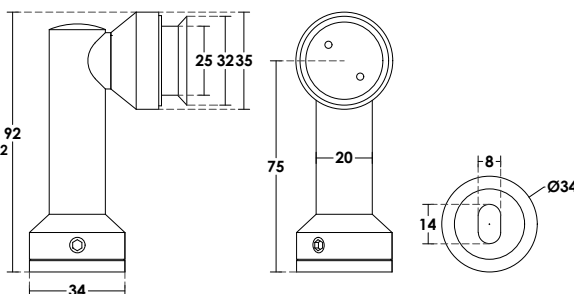

PCA-FC04
Facade Wall - Glass Clamp
 10-12mm | Glass Thickness
 50 kg | Max. Weight
 Stainless Steel 304 | Material
 Satin | Finish



PCA-FH12-A | FH12-B
Bottom Patch Fitting
 100 kg | Max. Weight
 10-12mm | Glass Thickness
 Stainless Steel 304 | Material
 Satin | Finish

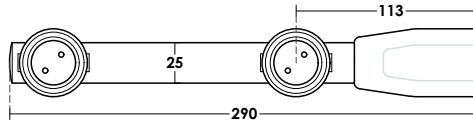

Glass Cut

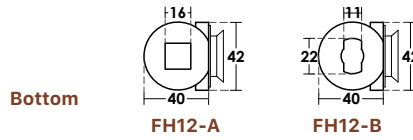
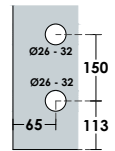

PCA-FH13
Top Patch Fitting
 10-12mm | Glass Thickness
 Stainless Steel 304 | Material
 Satin | Finish

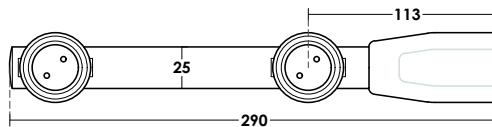

Glass Cut

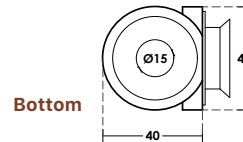
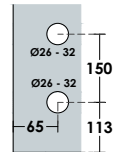

PCA-FH10L
Patch Fitting
 10-12mm | Glass Thickness
 Stainless Steel 304 | Material
 Satin | Finish

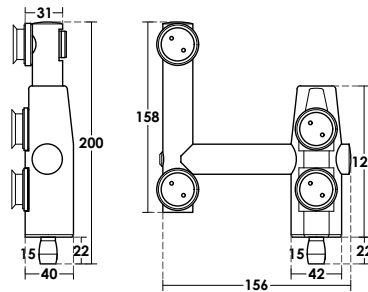

Glass Cut

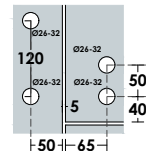

PCA-FH10R
Patch Fitting
 10-12mm | Glass Thickness
 Stainless Steel 304 | Material
 Satin | Finish

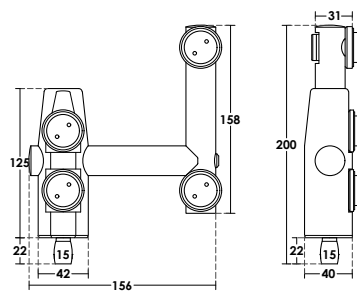

Glass Cut

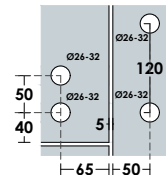

PCA-FH11
Patch Fitting
 10-12mm | Glass Thickness
 Stainless Steel 304 | Material
 Satin | Finish

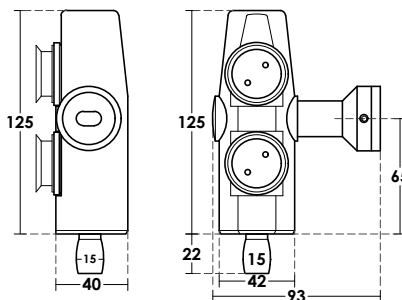

Glass Cut

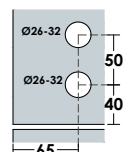

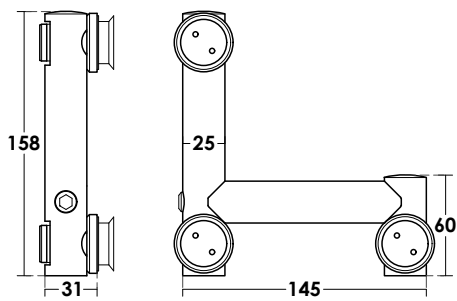

Glass Cut

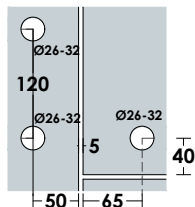

**PCA-FH15
Patch Fitting**
10-12mm | Glass Thickness
Stainless Steel 304 | Material
Satin | Finish

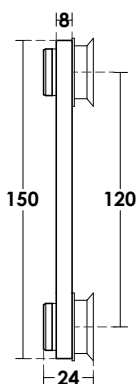

Glass Cut

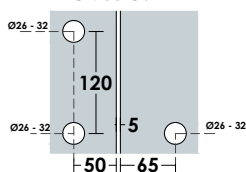

**PCA-FC09
Top Patch Fitting**
10-12mm | Glass Thickness
Stainless Steel 304 | Material
Satin | Finish

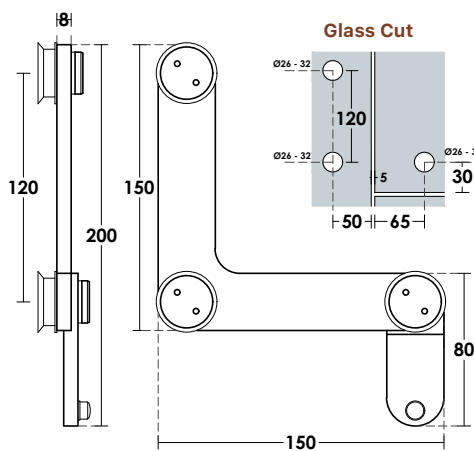

Glass Cut

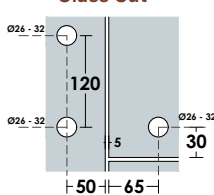

**PCA-FC10
Patch Fitting**
10-12mm | Glass Thickness
Stainless Steel 304 | Material
Satin | Finish

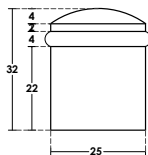

SP10B

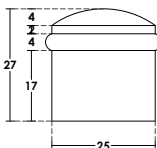
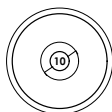

SP10



**PCA-SP10
Floor Stop**
Stainless Steel 304 | Material
Satin | Finish



PCA-ML01
Top Pivot Ø12mm
 50 kg | Max. Weight
 Stainless Steel 304 | Material
 Satin | Finish

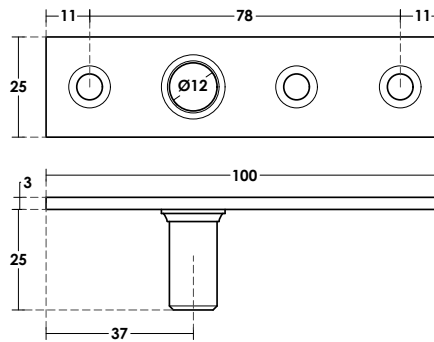

PCA-ML03
Top Pivot Ø15mm
 50 kg | Max. Weight
 Stainless Steel 304 | Material
 Satin | Finish

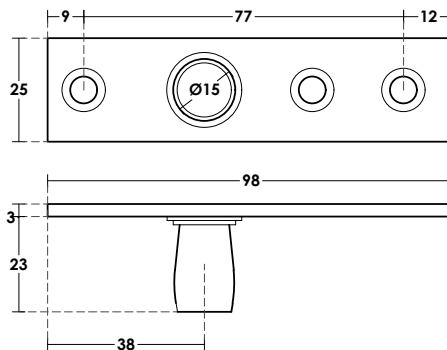

PCA-KZ01
Bottom Pivot
 50 kg | Max. Weight
 Stainless Steel 304 | Material
 Satin | Finish

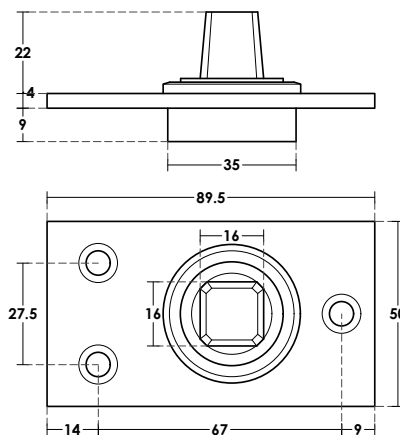

PCA-KZ02
Bottom Pivot
 50 kg | Max. Weight
 Stainless Steel 304 | Material
 Satin | Finish

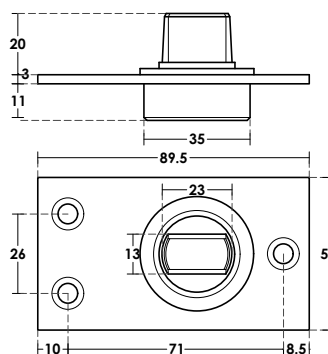

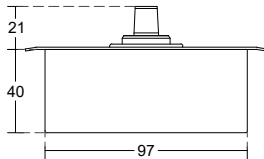
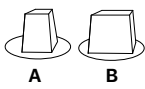
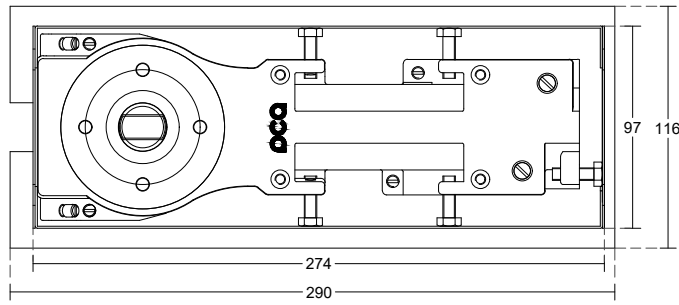

**PCA-650
Floor Spring**

100 kg | Max. Weight
950mm|Max. Width
Opening Angle 130 °, Stop Angle 90 ° |Opening Angle
Stainless Steel 304 | Material
Satin | Finish

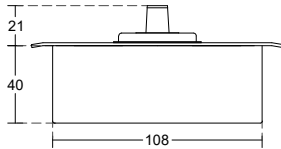
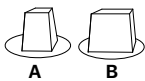
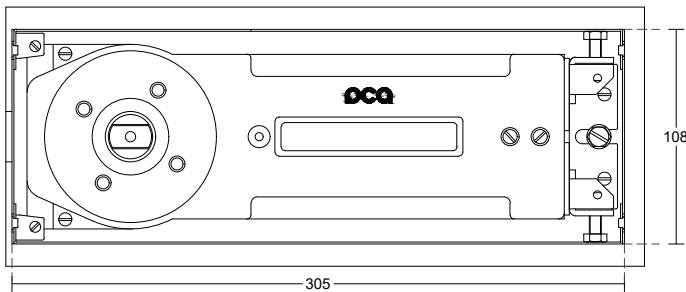

**PCA-840
Floor Spring**

120 kg | Max. Weight
Stainless Steel 304 | Material
Satin | Finish

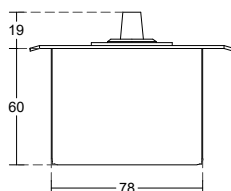
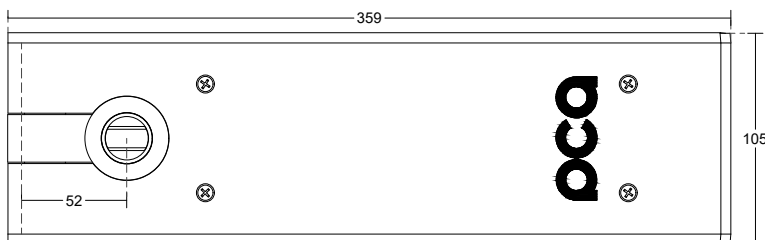

**PCA-800
Floor Spring**

300 kg | Max. Weight
Stainless Steel 304 | Material
Satin | Finish

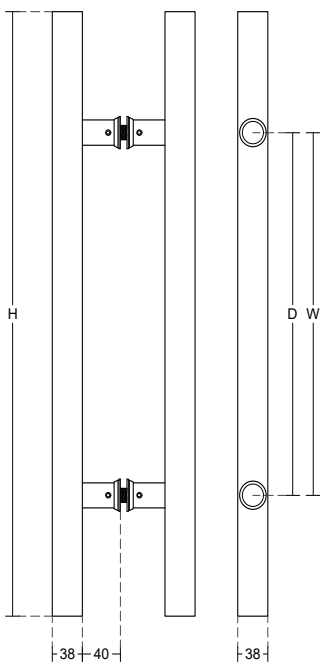
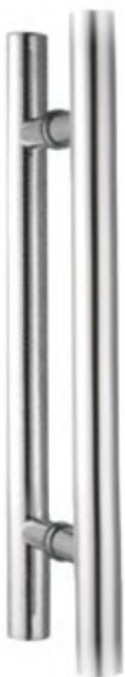

AVAILABLE DIMENSIONS

	HEIGHT	C-C-D	C-C-W
HD01A	60cm	36cm	
HD01B/HD01BW	80cm	50cm	62,5cm
HD01C/HD01CW	100cm	60cm	82,5cm
HD01D/HD01DW	120cm	80cm	90cm
HD01E/HD01EW	150cm	100cm	102,5cm
HD01F/HD01FW	180cm	120cm	130cm
HD01G	200cm	140cm	
HD01H	50cm	23cm	

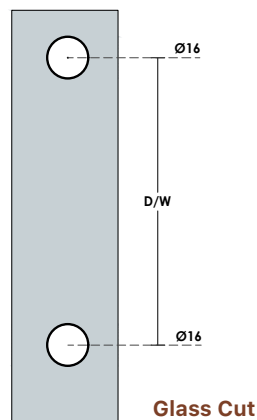

PCA-HD01
Door Handle Ø38mm
 10 mm | Glass Thickness
 Stainless Steel 304 | Material
 Satin | Finish

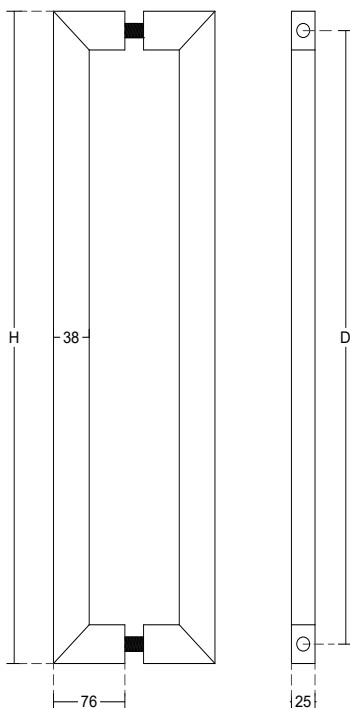

AVAILABLE DIMENSIONS

	HEIGHT	C-C-D
HD03A	64cm	60cm
HD03B	104cm	100cm
HD03C	144cm	140cm
HD03D	36cm	32cm

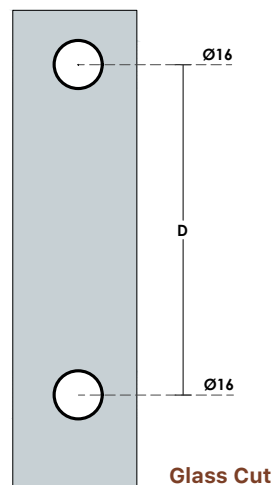

PCA-HD03
Door Handle 25x38 mm
 10 mm | Glass Thickness
 Stainless Steel 304 | Material
 Satin | Finish

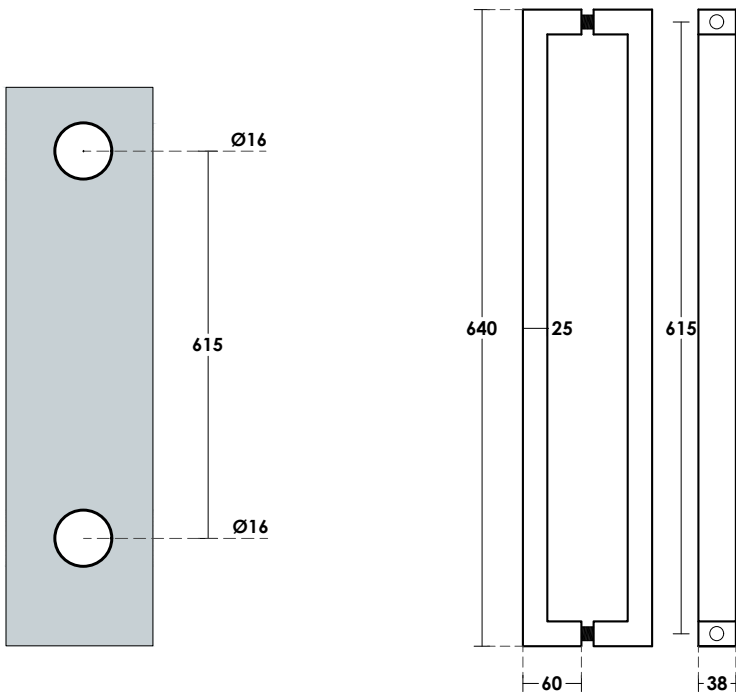

PCA-HD13
Door Handle 38x25 mm
 10 mm | Glass Thickness
 Stainless Steel 304 | Material
 Satin | Finish

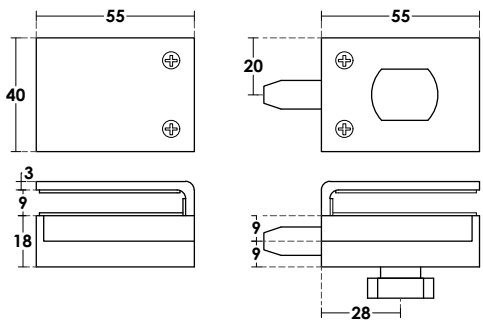

PCA-BL08
Glass-Glass Bolt
 10,12 mm | Glass Thickness
 Zinc Alloy | Material
 Satin | Finish

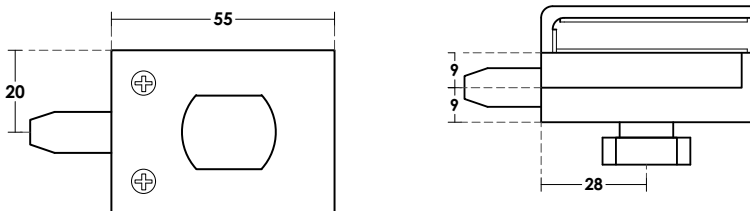

PCA-BL08S
Wall-Glass Bolt
 10,12 mm | Glass Thickness
 Zinc Alloy | Material
 Satin | Finish

HD06



HD06A

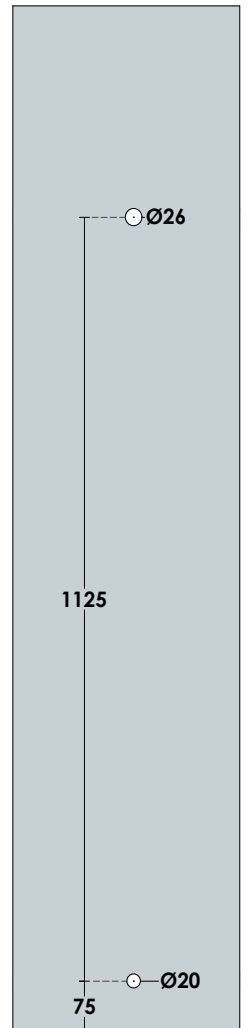
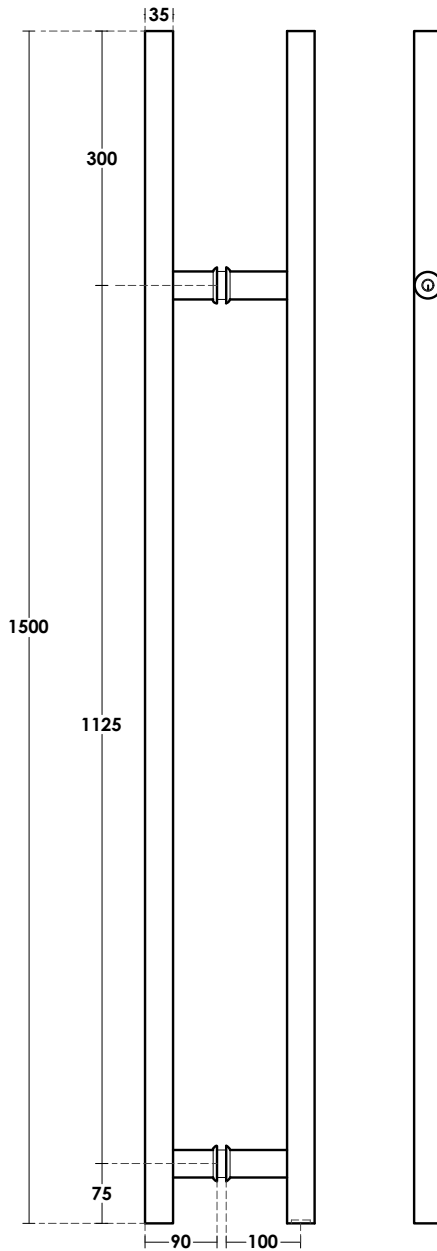
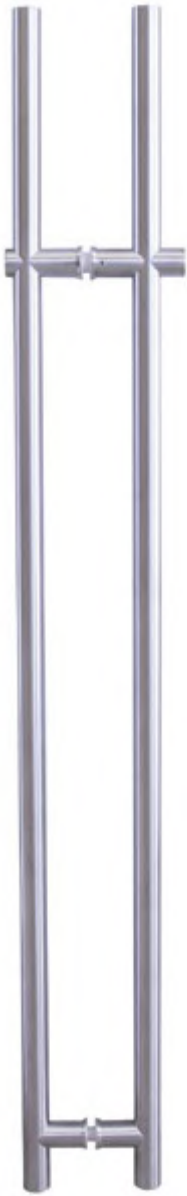

PCA-HD06
Door Lock - Handle Ø35mm
 10-12 mm | Glass Thickness
 Stainless Steel 304 | Material
 Satin | Finish

Glass Cut

NEW

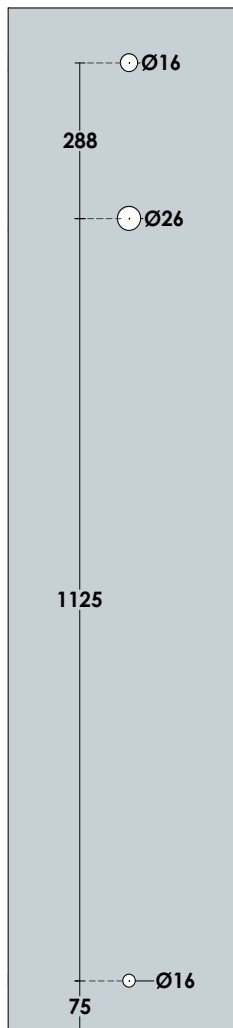

Glass Cut

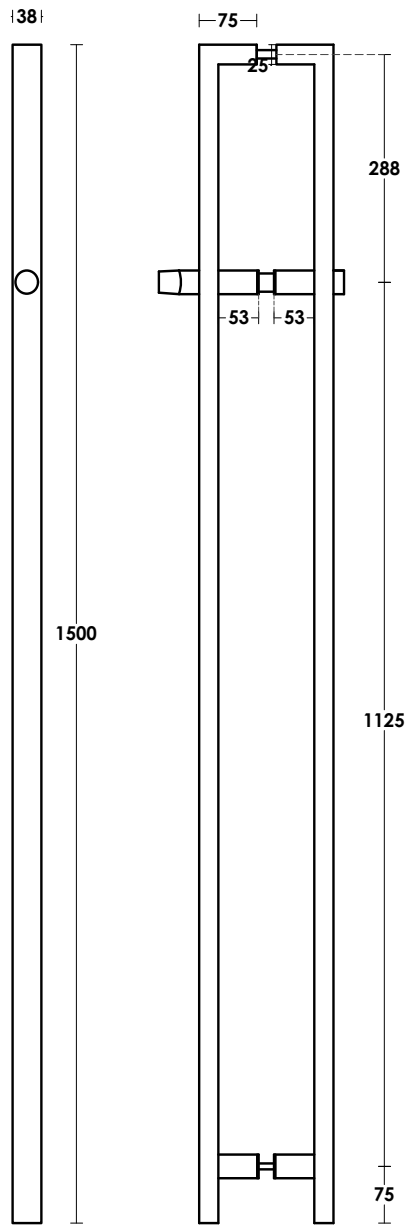

FAÇADES

PCA-HD14
Door Lock - Handle Ø35mm
 10-12 mm | Glass Thickness
 Stainless Steel 304 | Material
 Satin | Finish

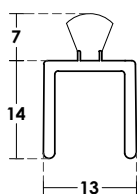

PCA-S13
Brush Waterproof Seal
 10,12mm | Glass Thickness
 220, 250, 300, 350 cm | Length
 PVC | Material

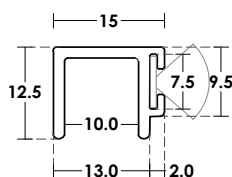

PCA-S14
Brush Waterproof Seal
 10 mm | Glass Thickness
 250 cm | Length
 PVC | Material

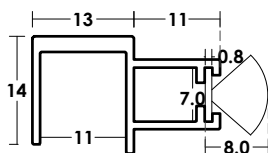

PCA-S14A
Brush Waterproof Seal
 10 mm | Glass Thickness
 250 cm | Length
 PVC | Material

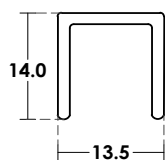

PCA-S17
Waterproof Seal
 8,10mm | Glass Thickness
 220 cm | Length
 PVC | Material

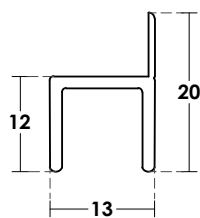

PCA-S18
Waterproof Seal
 10,12mm | Glass Thickness
 250, 300, 400cm | Length
 PVC | Material

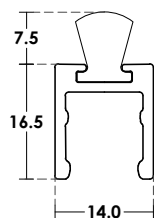

PCA-S20
Brush Waterproof Seal
 10mm | Glass Thickness
 280 cm | Length
 Aluminium | Material
 Natural Anodize | Finish

Shower Cabins & WC Partitions	8
Doors & Office Partitions	81
Facades	169
Folding	199
Guillotine	209
Spiders	215
Balcony Railings	225
Inox Railings	273
Staircase	293
Canopies	297
Miscellaneous & Consumables	307

DR01 | FOLDING SERIES



SHOCK DOOR INSTALLATION

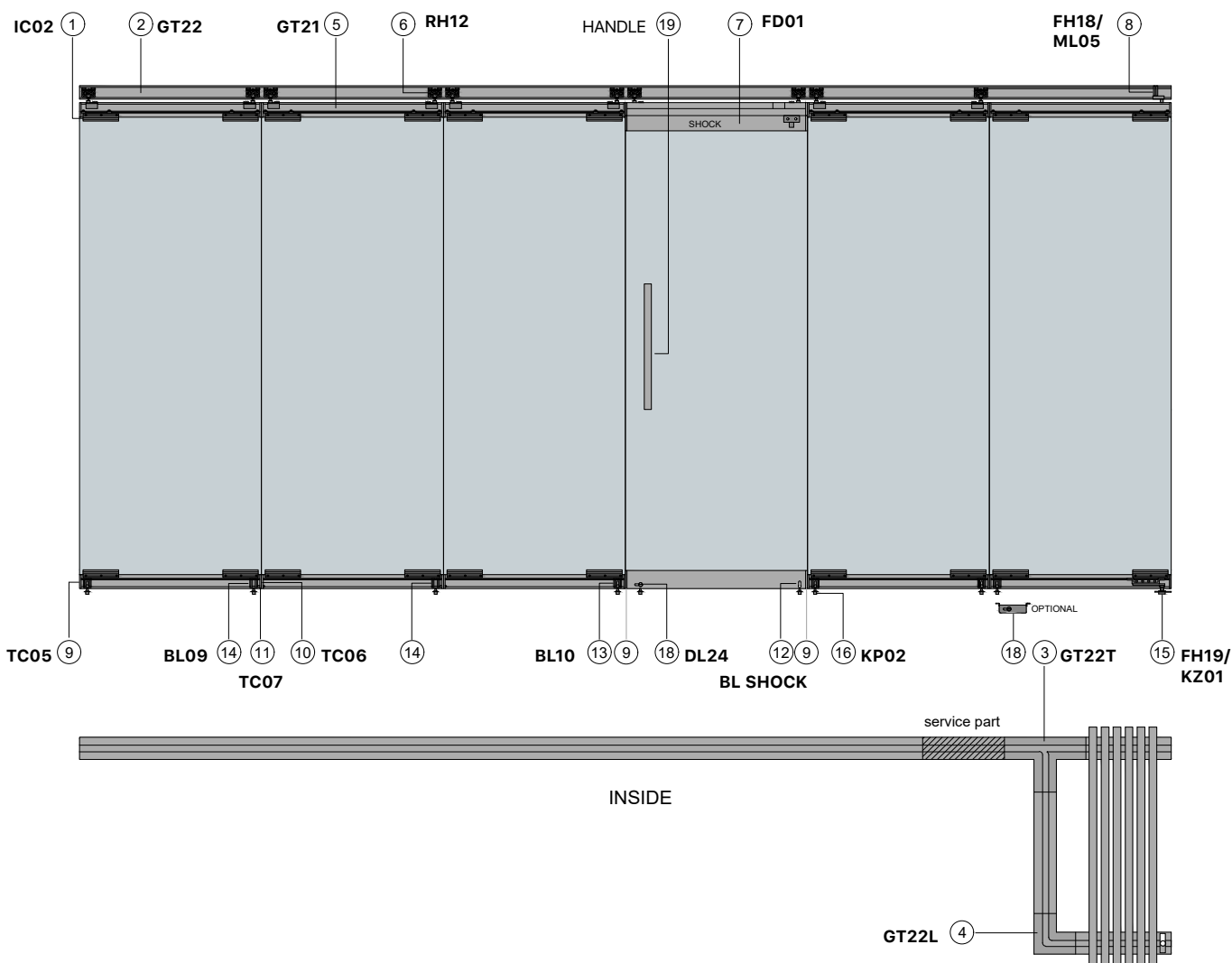

FOLDING DOORS

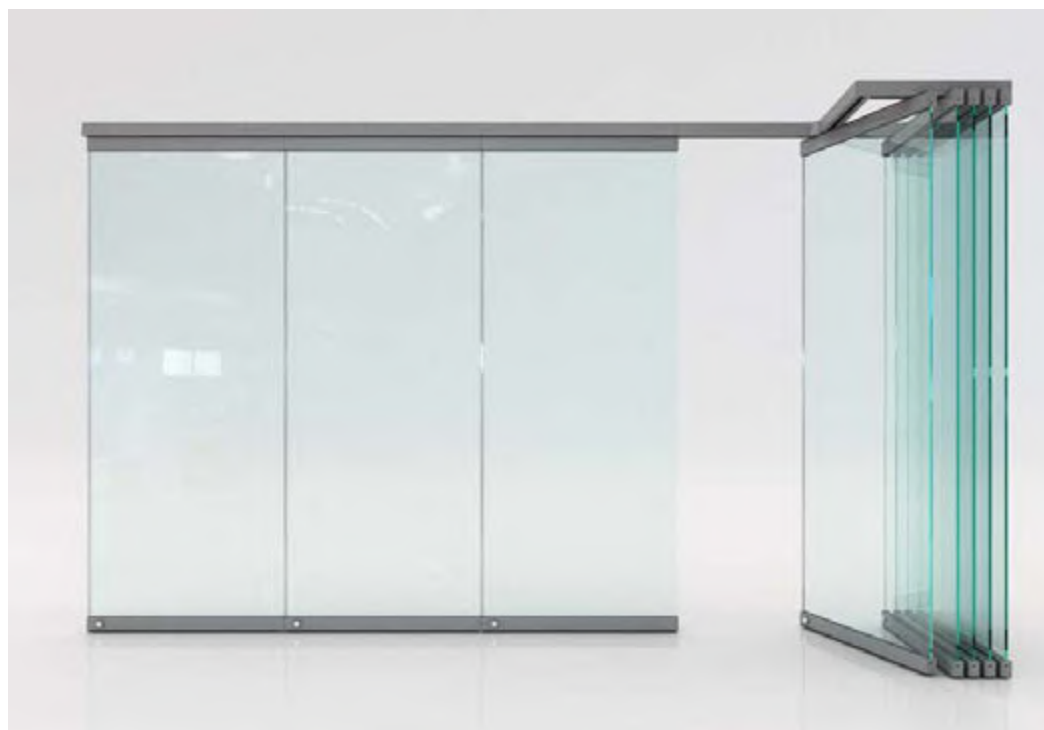
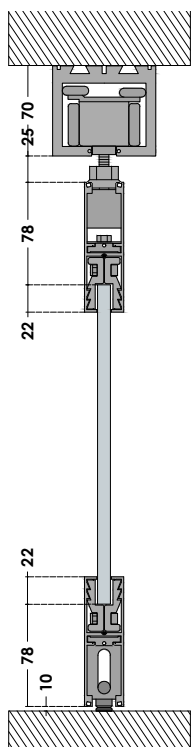

DR02 | FOLDING SERIES

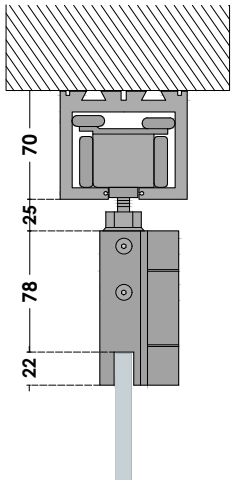

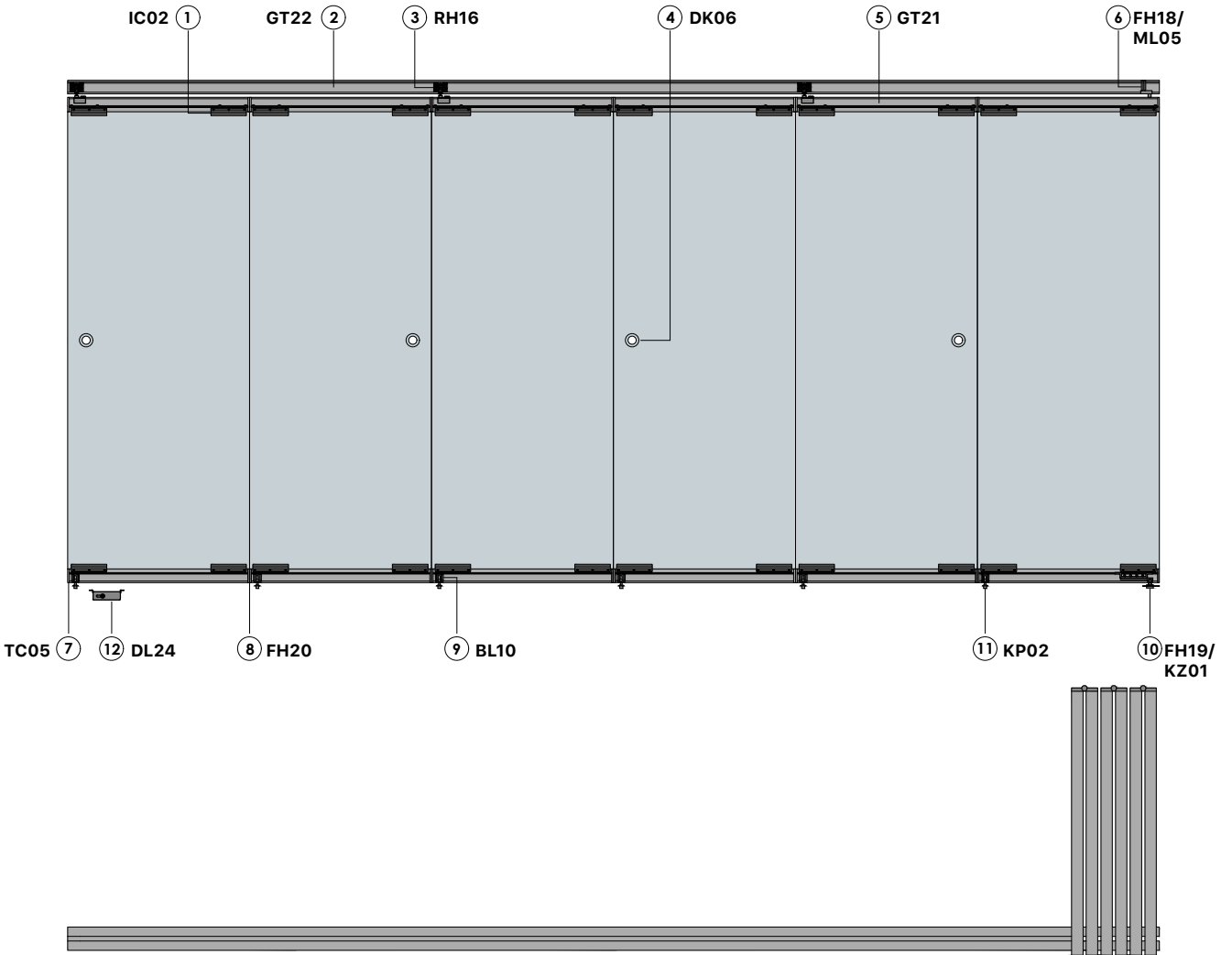

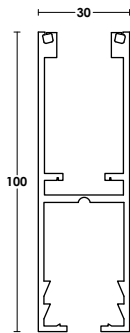

PCA-GT21
Rail Track Profile
 580cm | Length
 Aluminium | Material
 Natural Anodize | Finish

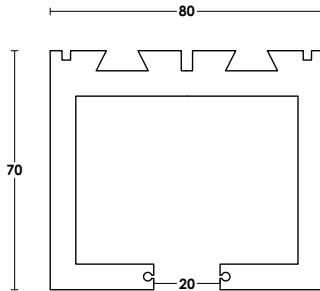

PCA-GT22
Guide Track Profile
 580cm | Length
 Aluminium | Material
 Natural Anodize | Finish

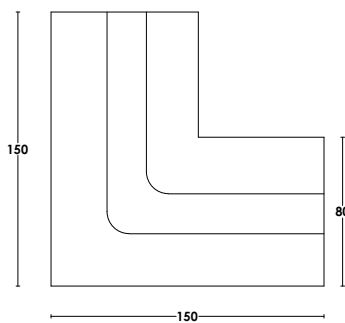

PCA-GT22L
90° Guide Track Junction
 Aluminium | Material
 Natural Anodize | Finish

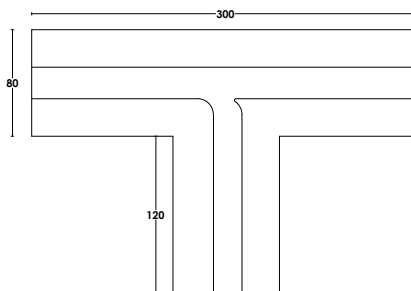

PCA-GT22T-L | GT22T-R
T Guide Track Junction
 Aluminium | Material
 Natural Anodize | Finish

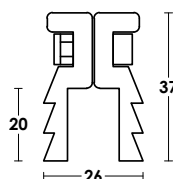

PCA-IC01 | IC02 | IC03
Facade Fitting
 10mm | Glass Thickness
 20cm, 30cm, 40cm | Length
 Aluminium | Material
 Satin | Finish

PCA-IC04 | IC05
Facade Fitting
 12mm | Glass Thickness
 30cm, 40cm | Length
 Aluminium | Material
 Satin | Finish

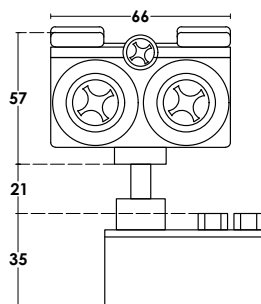

PCA-RH12
Roller Hanger
 100 kg | Max. Weight
 Stainless Steel 304 | Material
 Satin | Finish

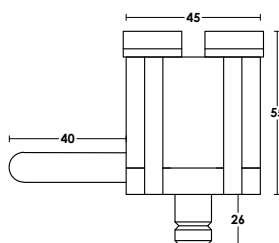

PCA-BL09
Inner Bolt
 Stainless Steel | Material
 Satin | Finish

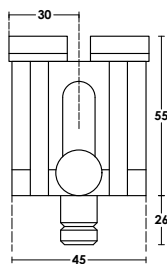

PCA-BL10
Inner Bolt
 Stainless Steel | Material
 Satin | Finish

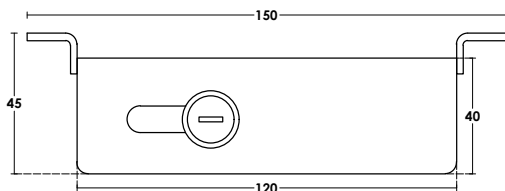

PCA-DL24
Inner Door Lock
 Aluminium | Material
 Satin | Finish

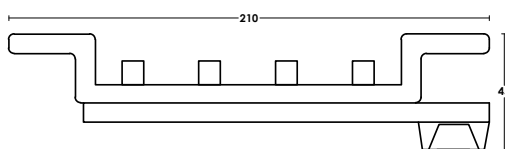

PCA-FH19
Door Bottom Pivot
 Stainless Steel | Material
 Satin | Finish



PCA-ML05/FH18

Top Pivot

PVC & Aluminium | Material
Black & White | Finish

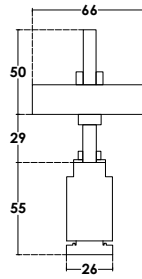

PCA-FH21

Door Bottom Pivot

Stainless Steel | Material
Satin | Finish

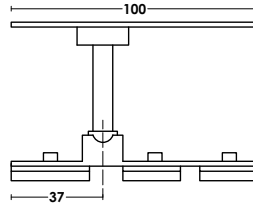

PCA-SP13

Stop

PVC & Stainless Steel | Material
Satin | Finish

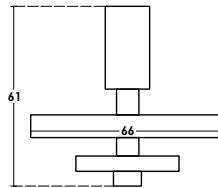

PCA-FH20

Rail Hinge

Stainless Steel | Material
Black | Finish

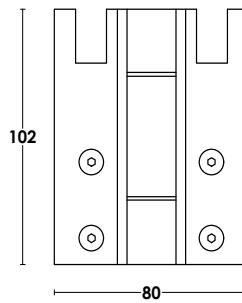

PCA-DR01-DS

Sliding Door System

Aluminium | Material
Natural Anodize | Finish

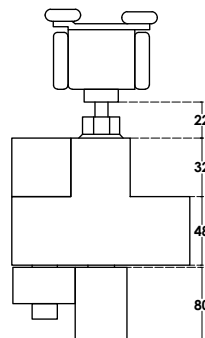

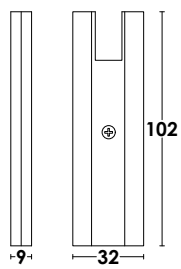

PCA-TC05
End Cap
PVC | Material
Black | Finish

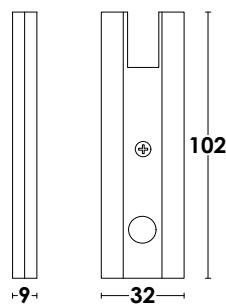

PCA-TC06
End Cap
PVC | Material
Black | Finish

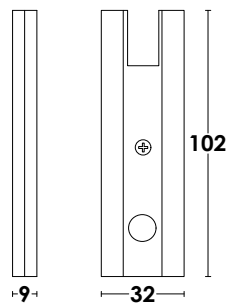

PCA-TC07
End Cap
PVC | Material
Black | Finish

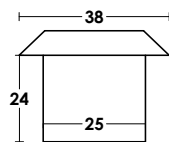

PCA-KP02
Floor Socket
Stainless Steel | Material
Satin | Finish



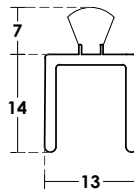

PCA-S13
Brush Waterproof Seal
10,12mm | Glass Thickness
220, 250, 300, 350 cm | Length
PVC | Material

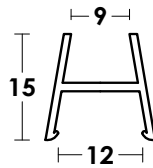

PCA-S16A
Waterproof Seal
10mm | Glass Thickness
300cm | Length
PVC | Material

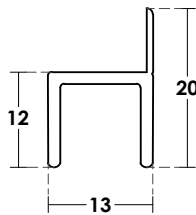

PCA-S18
Waterproof Seal
10,12mm | Glass Thickness
220, 250, 300, 400cm | Length
PVC | Material

Shower Cabins & WC Partitions	8
Doors & Office Partitions	81
Facades	169
Folding	199
Guillotine	209
Spiders	215
Balcony Railings	225
Inox Railings	273
Staircase	293
Canopies	297
Miscellaneous & Consumables	307

GL1 | GUILLOTINE SERIES







DESCRIPTION:

- Material Aluminium
- Mill finish
- Fit for 8mm tempered glass & 26mm double glazed tempered glass.
- Max width 3500 mm
- Upward and downward function
- Electrical open: Somfy Motor



8mm TEMPERED GLASS

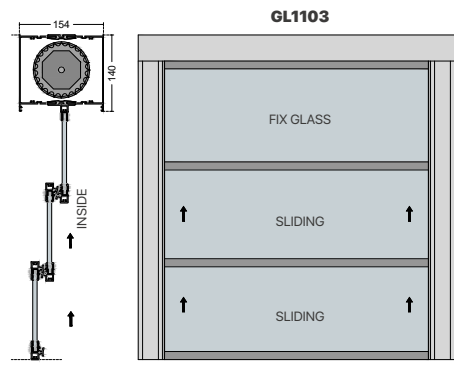
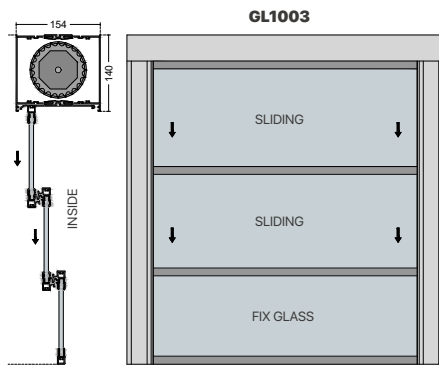
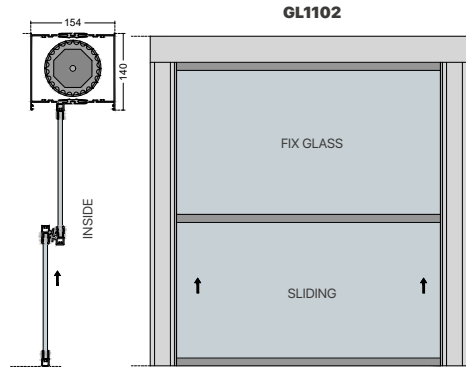
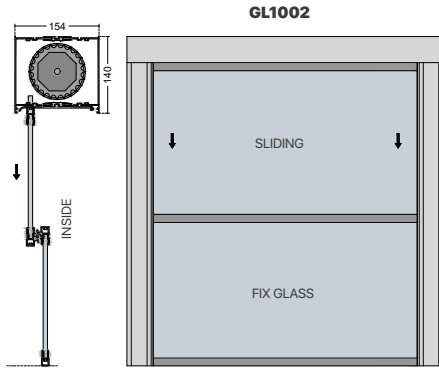

26mm DOUBLE GLAZED TEMPERED GLASS

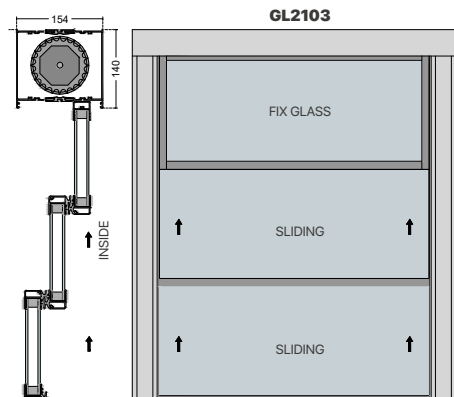
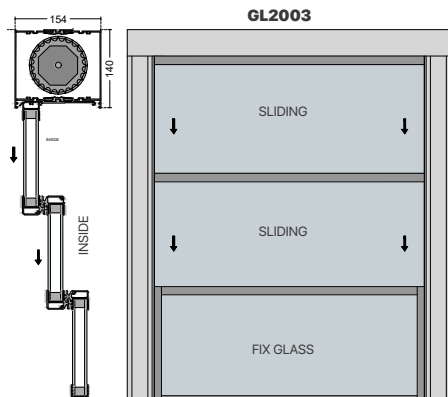
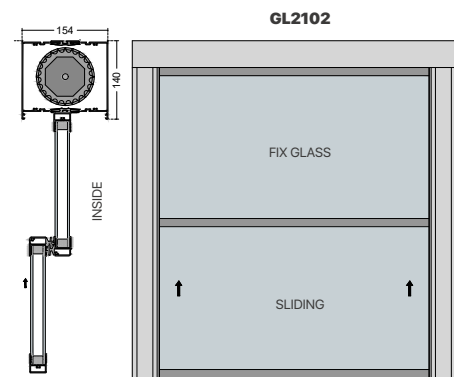
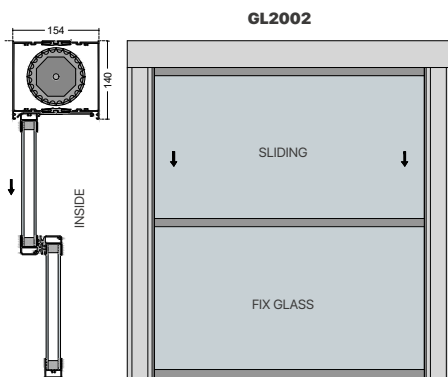

GL1002 / GL1102

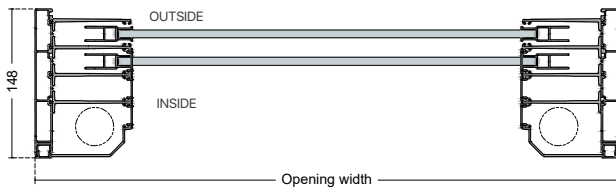

GL2002 / GL2102

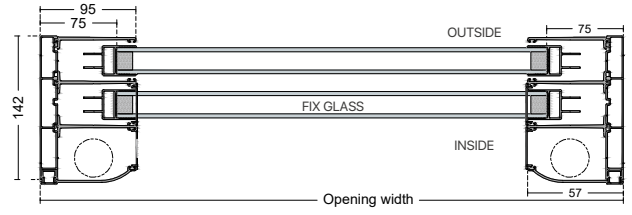

GL1003 / GL1103

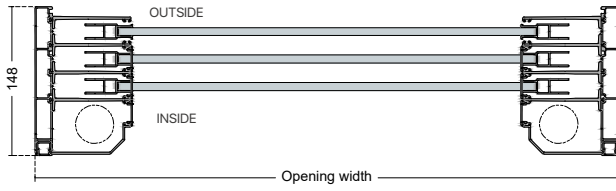

GL2003 / GL2103

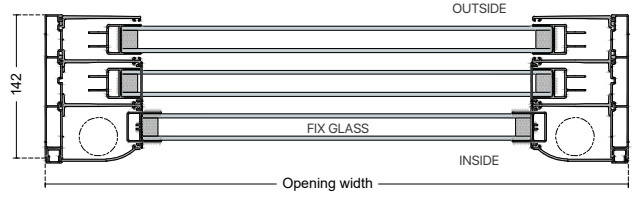

MAXIMUM DIMENSIONS

Single glass
8mm

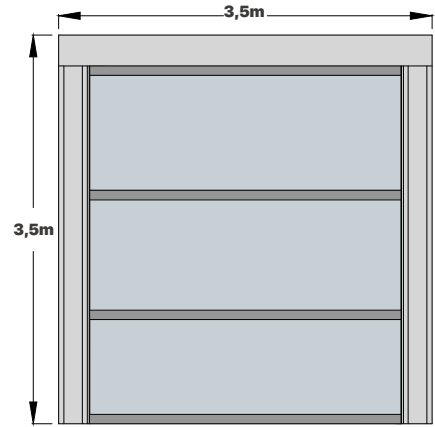
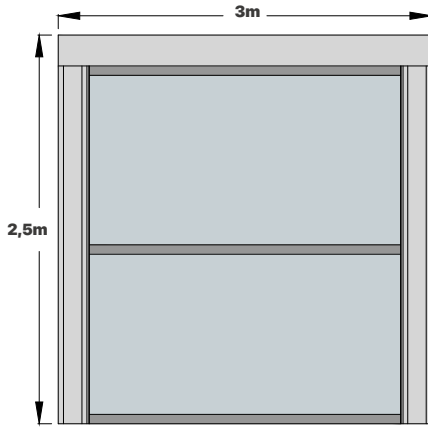

Double glazed
26mm

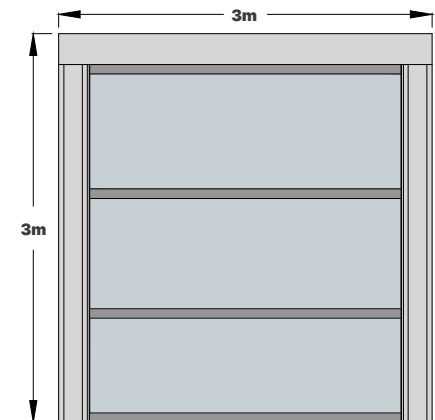
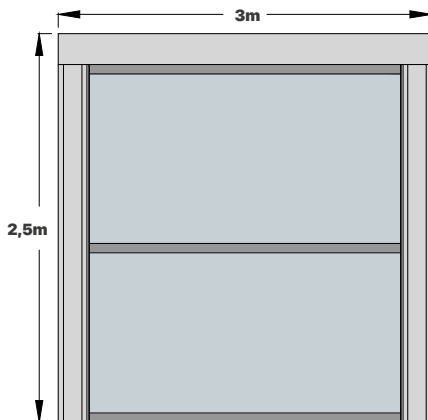

Shower Cabins & WC Partitions	8
Doors & Office Partitions	81
Facades	169
Folding	199
Guillotine	209
Spiders	215
Balcony Railings	225
Inox Railings	273
Staircase	293
Canopies	297
Miscellaneous & Consumables	307

S1 | SPIDER GLAZING SERIES



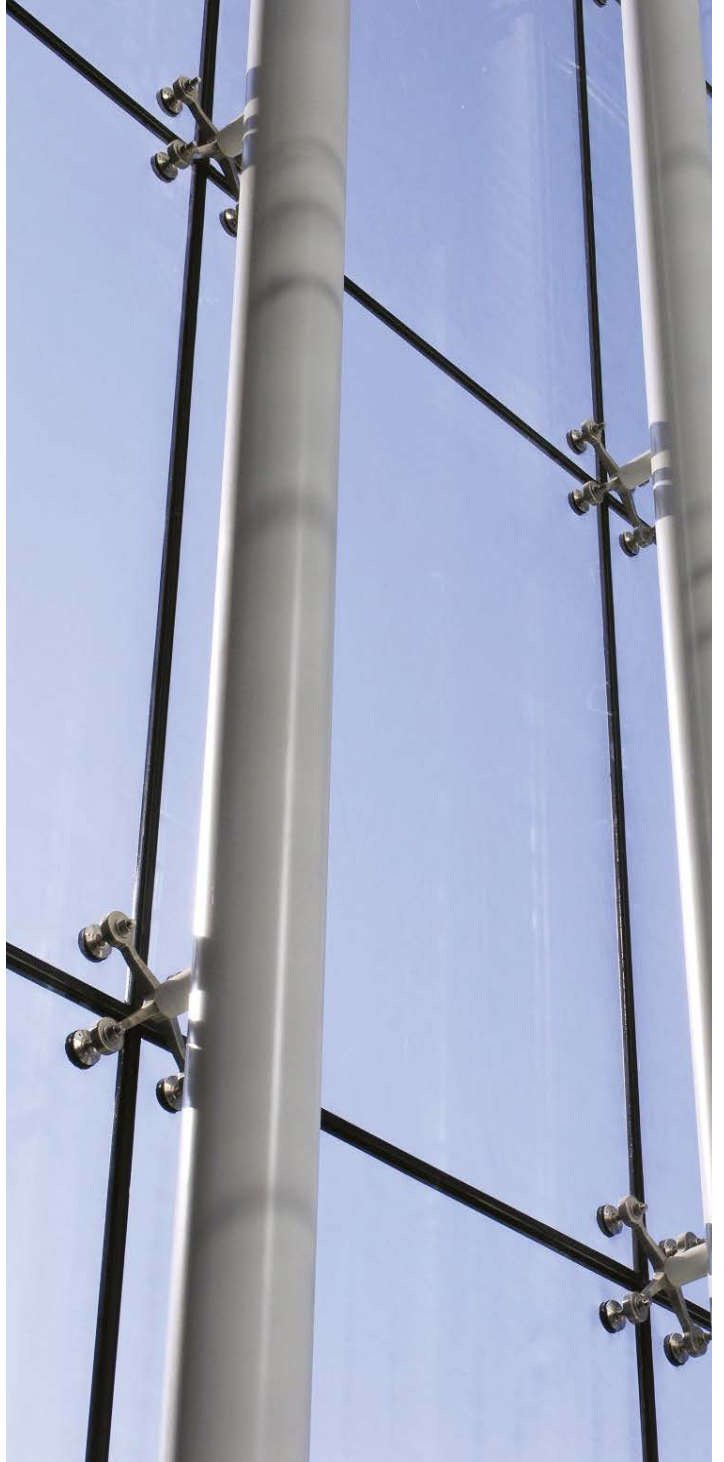

S2 | SPIDER GLAZING SERIES

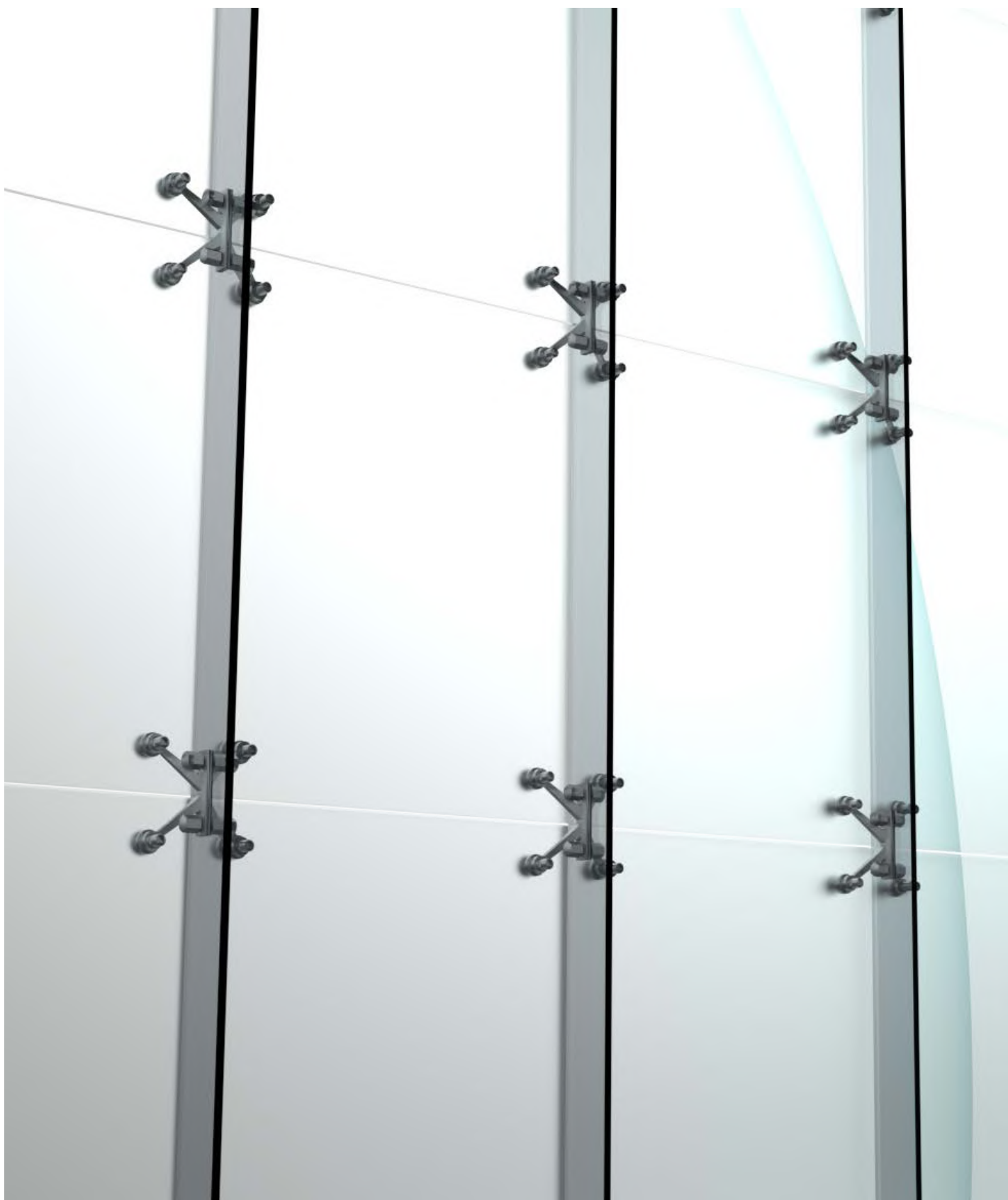





PCA-SD01
Spider Fitting
100kg | Weight
Stainless Steel 304 | Material
Satin | Finish

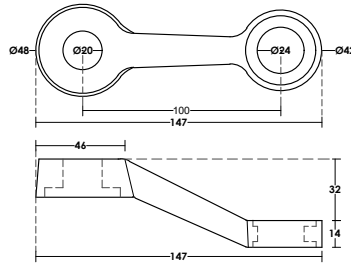

PCA-SD01A
Spider Fitting
100kg | Weight
Stainless Steel 304 | Material
Satin | Finish

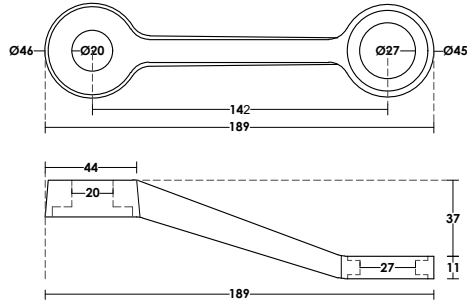

PCA-SD02A
Spider Fitting
100kg | Weight
Stainless Steel 304 | Material
Satin | Finish

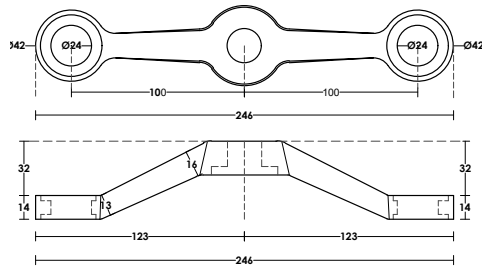

PCA-SD02B
Spider Fitting
100kg | Weight
Stainless Steel 304 | Material
Satin | Finish

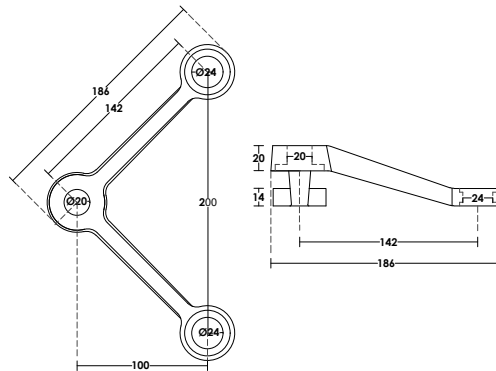

PCA-SD03
Threefold Spider Fitting
100kg | Weight
Stainless Steel 304 | Material
Satin | Finish

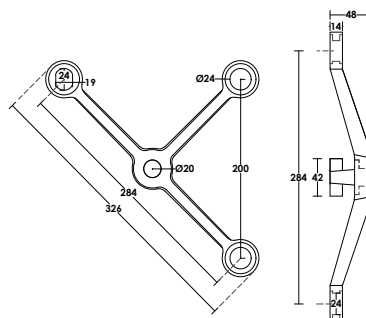

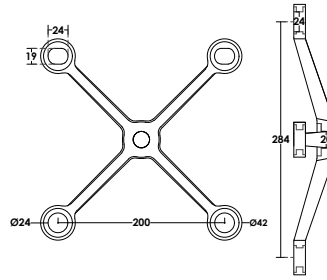

PCA-SD04
 Fourfold Spider Fitting
 100kg | Weight
 Stainless Steel 304 | Material
 Satin | Finish

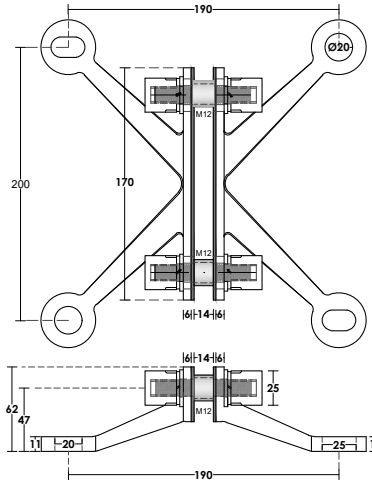

Glass Preparation

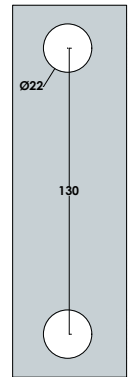

PCA-SD05
 Spider Fitting
 150kg | Weight
 10-20mm | Glass Thickness
 Stainless Steel 304 | Material
 Satin | Finish

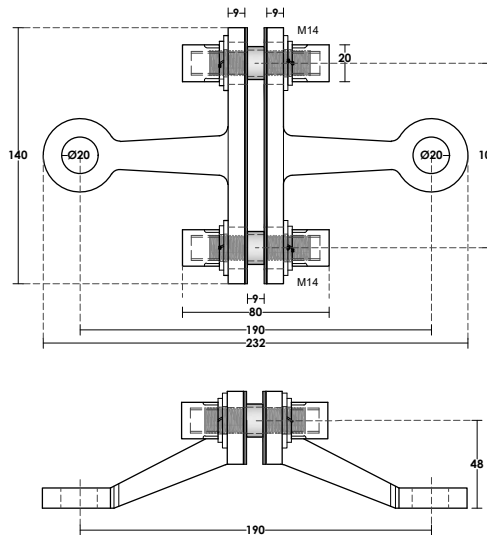

Glass Preparation

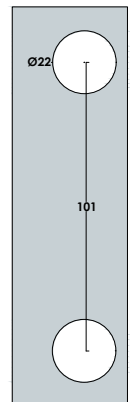

PCA-SD06
 Spider Fitting
 150kg | Weight
 10-20mm | Glass Thickness
 Stainless Steel 304 | Material
 Satin | Finish

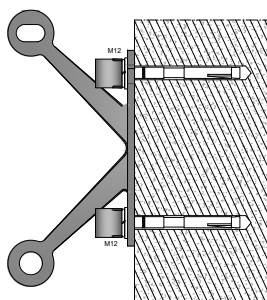

SD05

WALL INSTALLATION

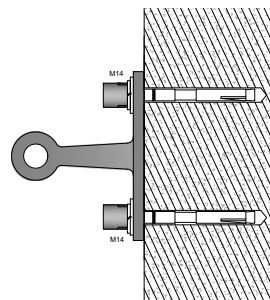

SD06

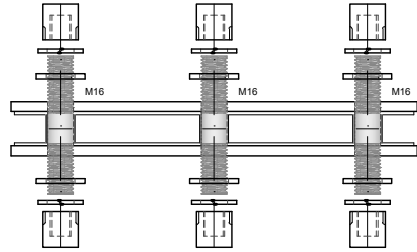
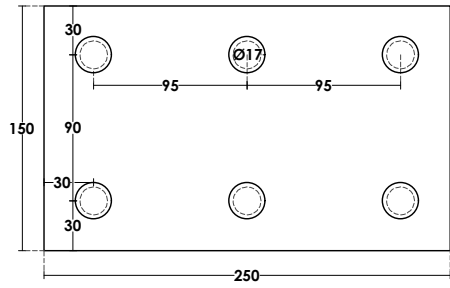

Glass Preparation

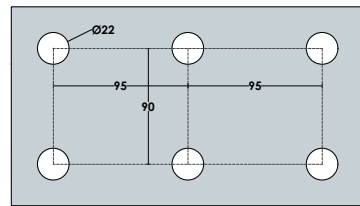

**PCA-SD07
Spider Fitting**

150kg | Weight
10-20mm | Glass Thickness
Ø20 | Glass Preparation
Stainless Steel 304 | Material
Satin | Finish

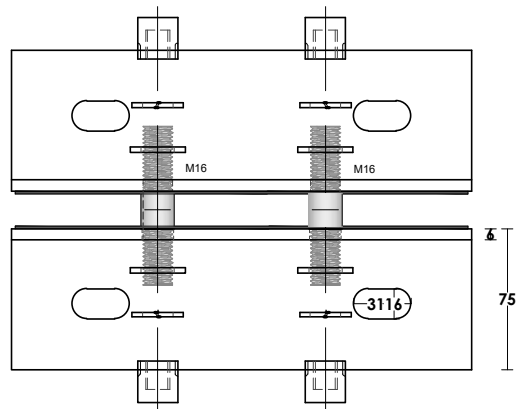
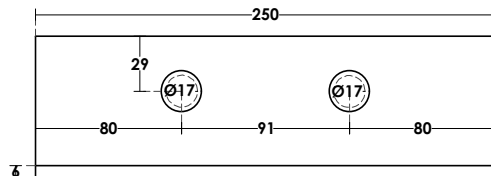

Glass Preparation

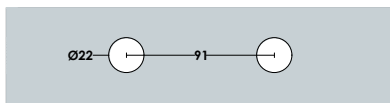

**PCA-SD08
Spider Fitting**

150kg | Weight
10-20mm | Glass Thickness
Ø20 | Glass Preparation
Stainless Steel 304 | Material
Satin | Finish

Glass Preparation

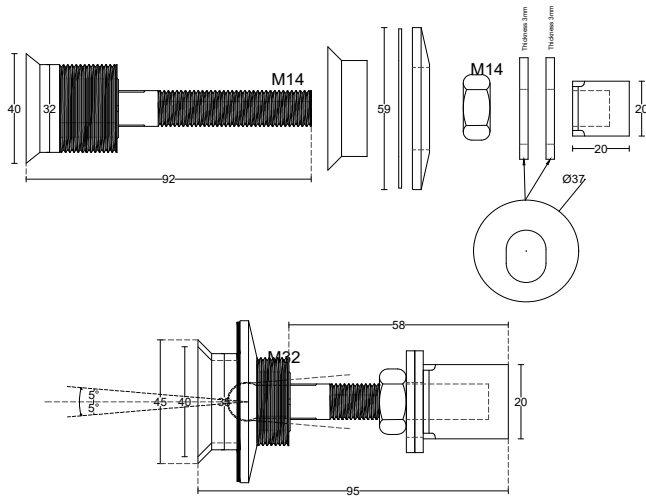
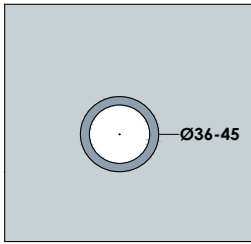

**PCA-HN03
Spider Head Fitting**

150kg | Weight
18-30mm | Glass Thickness
Stainless Steel 304 | Material
Satin | Finish

Glass Preparation

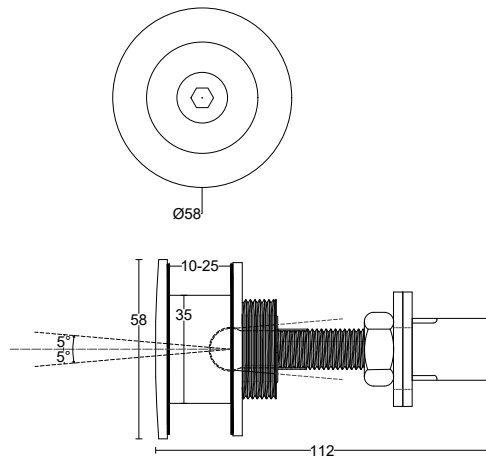
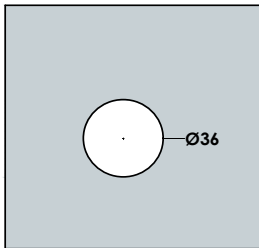

**PCA-HN04
Spider Head Fitting**

150kg | Weight
10-25mm | Glass Thickness
Stainless Steel 304 | Material
Satin | Finish

Glass Preparation

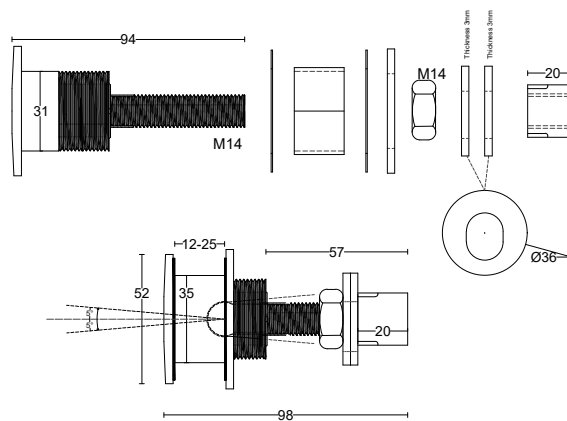
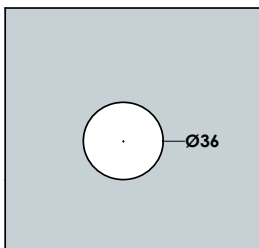

**PCA-HN05
Spider Head Fitting**

150kg | Weight
12-25mm | Glass Thickness
Stainless Steel 304 | Material
Satin | Finish



PCA-SS01
Spider Fitting
150kg | Weight
Stainless Steel 304 | Material
Satin | Finish

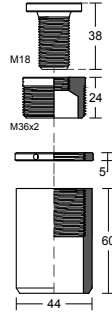
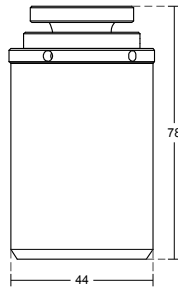

PCA-SS02
Spider Screw Fitting
100kg | Weight
Stainless Steel 304 | Material
Satin | Finish

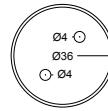
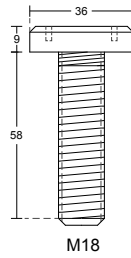

Shower Cabins & WC Partitions	8
Doors & Office Partitions	81
Facades	169
Folding	199
Guillotine	209
Spiders	215
Balcony Railings	225
Inox Railings	273
Staircase	293
Canopies	297
Miscellaneous & Consumables	307





GLASS RAILING BASES - TOP MOUNTED

M1 | RAILING BASE

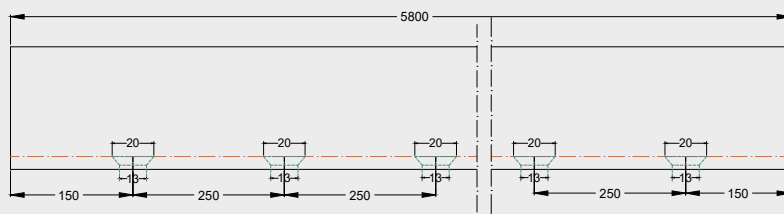
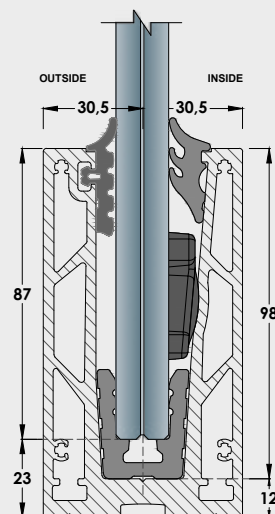
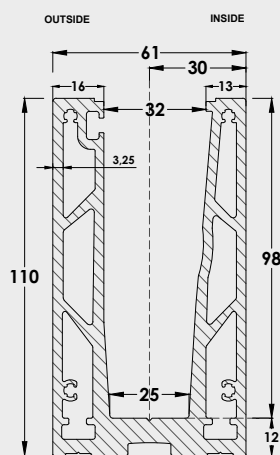
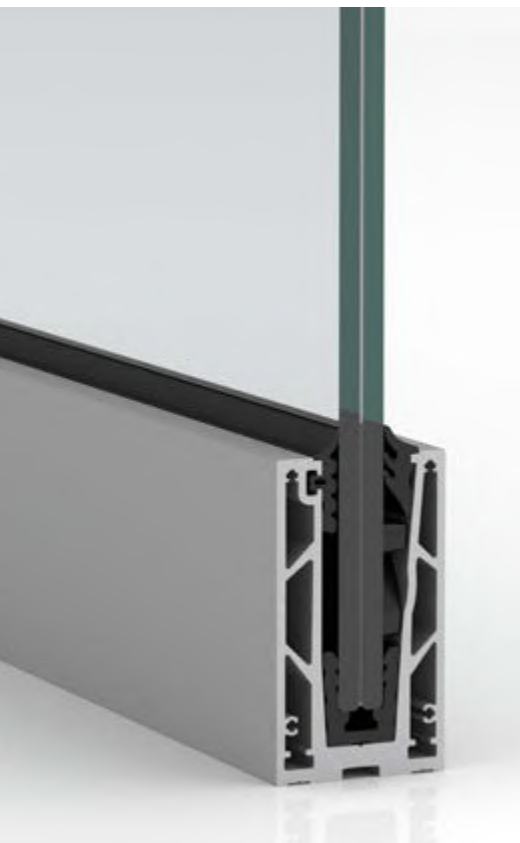

Profile Holes

Profile data

Product Code	Material	Finish	Length (mm)	Weight (kg/m)	Max Height (m)	Max Load (KN)	Glass Thickness
GM01	Aluminium	Satin	5800	5,621	1,1	1	13,52 - 17,52 - 21,52
GM01	Aluminium	Natural Anodize	5800	5,621	1,1	1	13,52 - 17,52 - 21,52

System components

Glass Thickness	Component 1	Component 2	Component 3	Component 4
13,52	GM01-12A	GM01-12B	GM01-12C	GM01SF-12
17,52	GM01-16A	GM01-16B	GM01-16C	GM01SF-16
21,52	GM01-20A	GM01-20B	GM01-20C	GM01SF-20

Sets/bar

Length: 6m	Length: 6m	Length: 6m	2X10 pieces	23 pieces	GM01EC (OPTIONAL)
30m Roll Unit		14m Roll Unit			

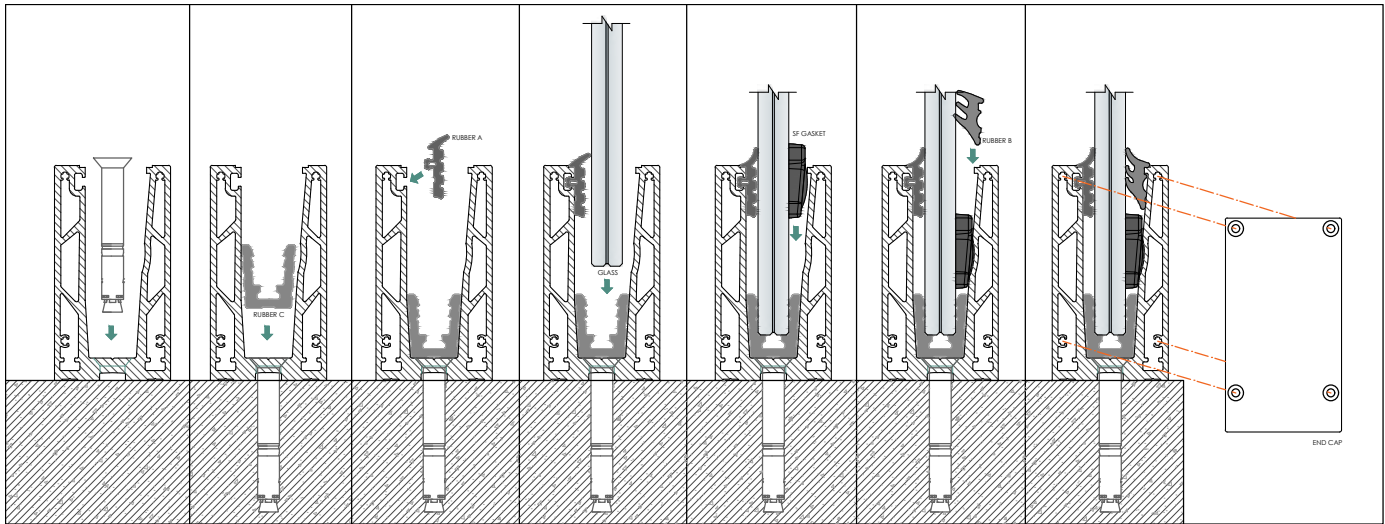

M1
GM01
TOP MOUNTED

M2 | RAILING BASE

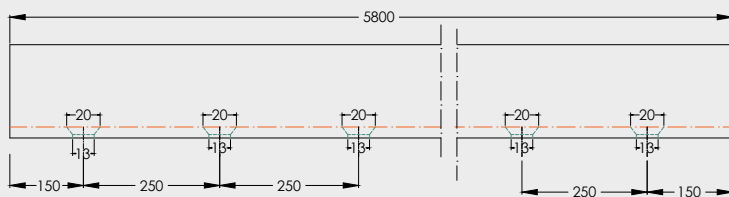
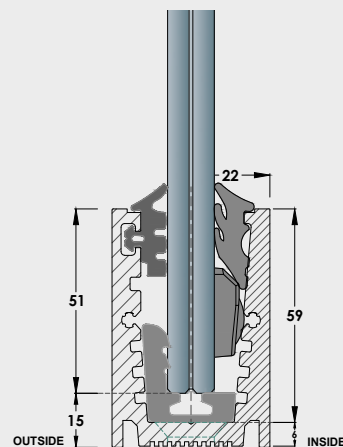
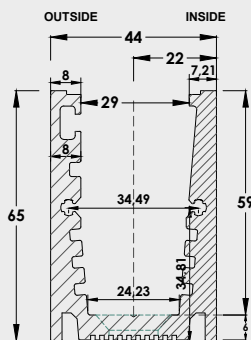

Profile Holes

Profile data

Product Code	Material	Finish	Length (mm)	Weight (kg/m)	Max Height (m)	Max Load (KN)	Glass Thickness
GM01A	Aluminium	Satin	5800	2,724	0,7	1	11,52 - 13,52
GM01A	Aluminium	Natural Anodize	5800	2,724	0,7	1	11,52 - 13,52

System components

11,52	Glass Thickness	GM01A-10A	GM01-16B	GM01A-10C	GM02SF-10
13,52	Glass Thickness	GM01A-12A	GM01-20B	GM01A-12C	GM02SF-12

Sets/bar

Length: 6m	Length: 6m	Length: 6m	2X10 pieces	23 pieces	GM01AEC (OPTIONAL)
30m Roll Unit		14m Roll Unit			

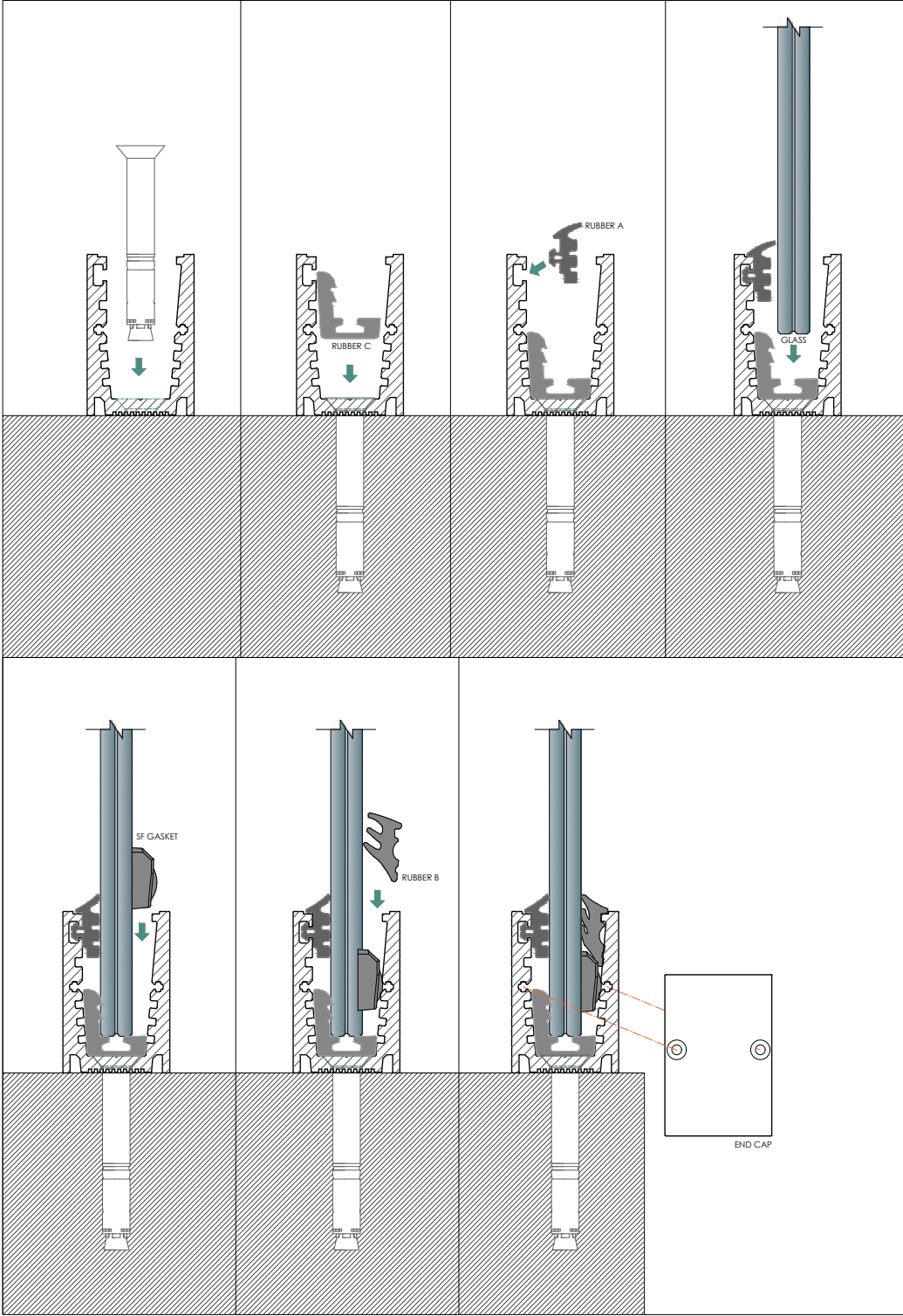

M2

GM01A
TOP MOUNTED

M3 | RAILING BASE

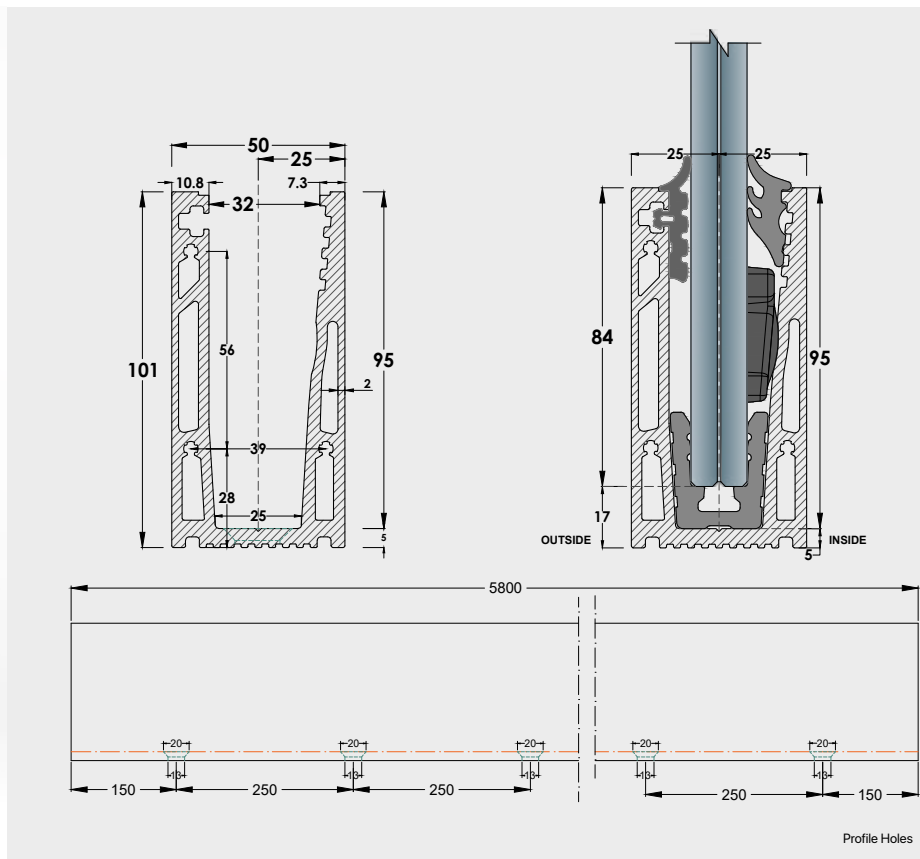

Profile data							
Product Code	Material	Finish	Length (mm)	Weight (kg/m)	Max Height (m)	Max Load (KN)	Glass Thickness
GM03	Aluminium	Satin	5800	3,934	0,9	1	13,52 - 17,52 - 21,52
GM03	Aluminium	Natural Anodize	5800	3,934	0,9	1	13,52 - 17,52 - 21,52

System components							
13,52	Glass Thickness	GM01-14A	GM01-12B	GM01-14C	GM01SF-12		
17,52	Glass Thickness	GM01-16A	GM01-16B	GM01-16C	GM01SF-16		
21,52	Glass Thickness	GM01-20A	GM01-20B	GM01-20C	GM01SF-20		

Sets/bar						
Length: 6m	Length: 6m	Length: 6m	2X10 pieces	23 pieces	GM03EC (OPTIONAL)	
30m Roll Unit		14m Roll Unit				

M3

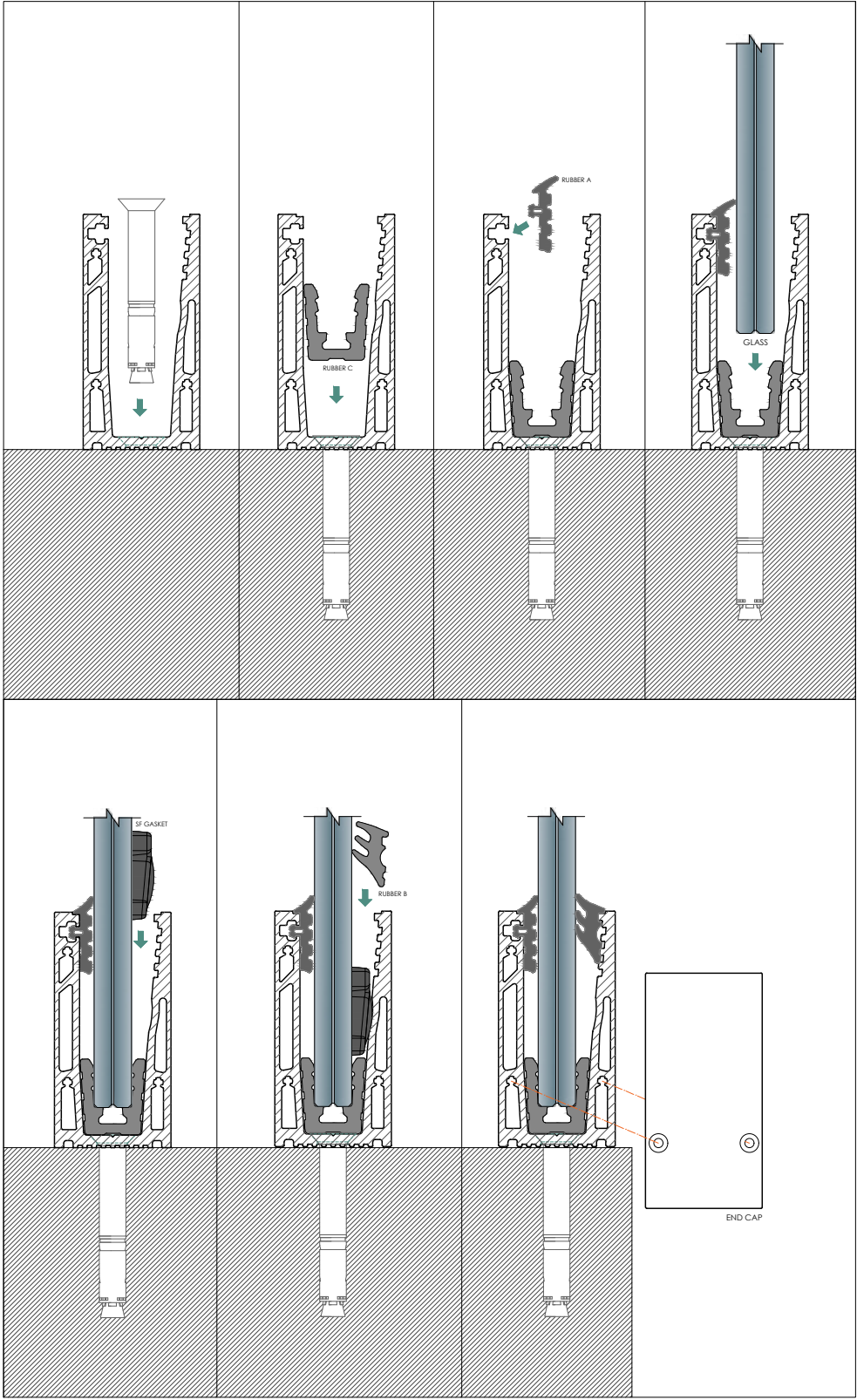

GM03
TOP MOUNTED



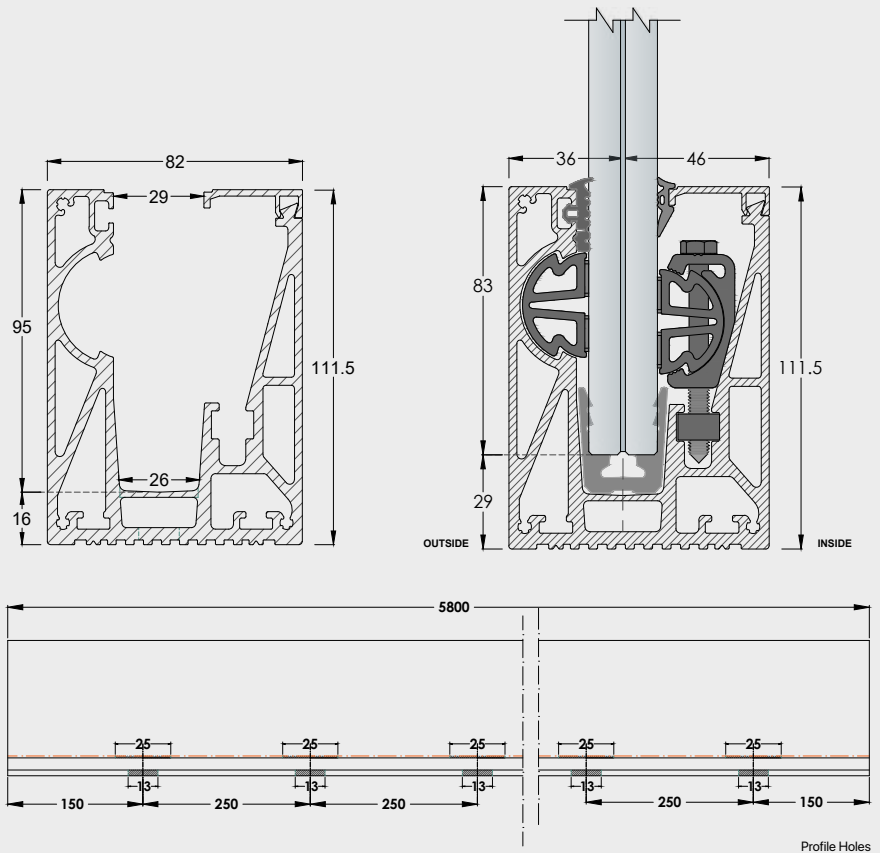



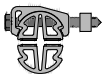

M10 | RAILING BASE



Profile data							
Product Code	Material	Finish	Length (mm)	Weight (kg/m)	Max Height (m)	Max Load (KN)	Glass Thickness
GM10	Aluminium	Satin	5800	5,640	1,1	1	21,52
GM10	Aluminium	Natural Anodize	5800	5,640	1,1	1	21,52

System components						
21,52	Glass Thickness	GM10-20A 	GM10-20B 	GM01-20C 	GM10-5 	

Sets/bar					
					
Length: 6m	Length: 6m	Length: 6m	24 pieces	23 pieces	GM10EC (OPTIONAL)
30m Roll Unit		14m Roll Unit			

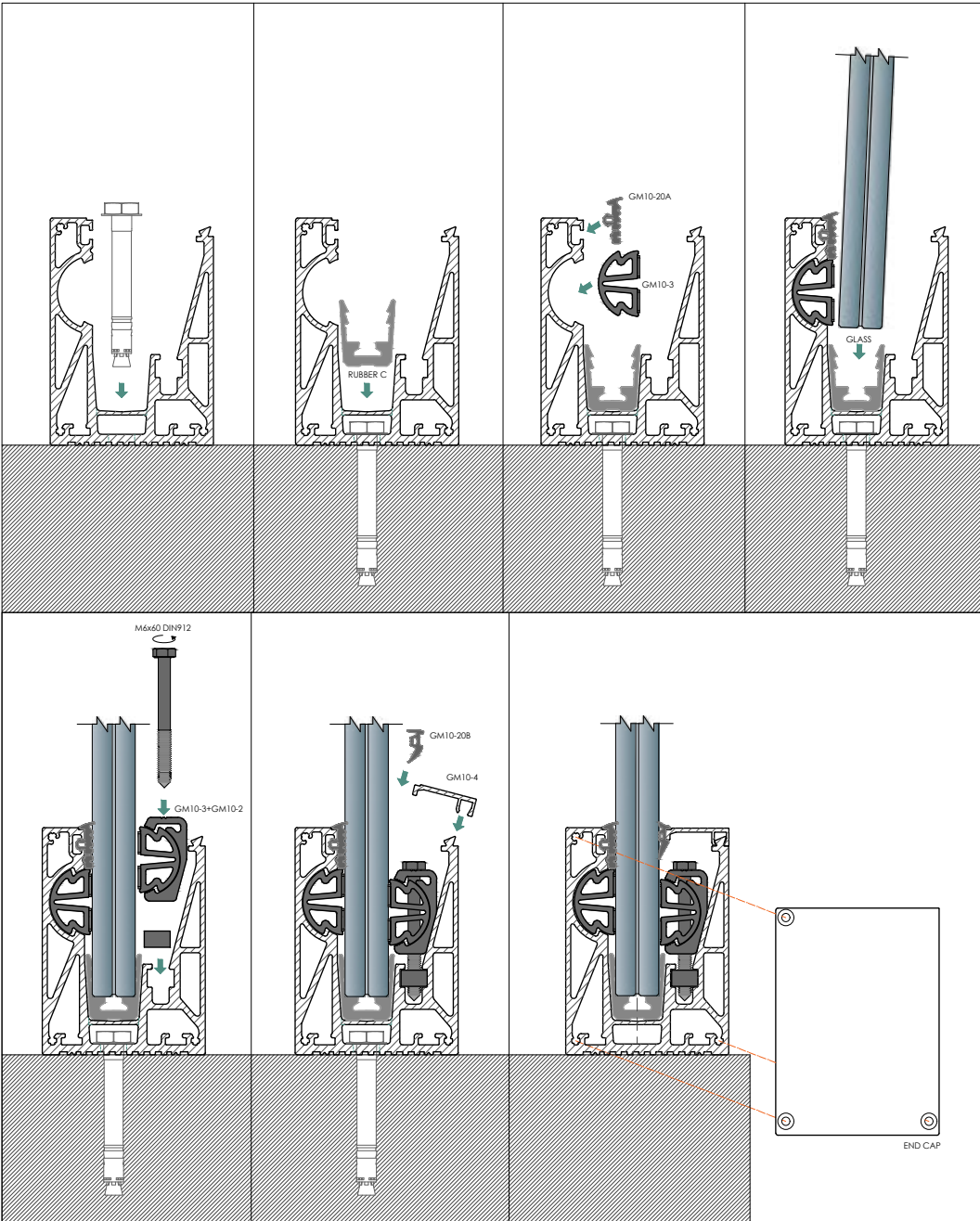

M10

GM10
TOP MOUNTED

M11



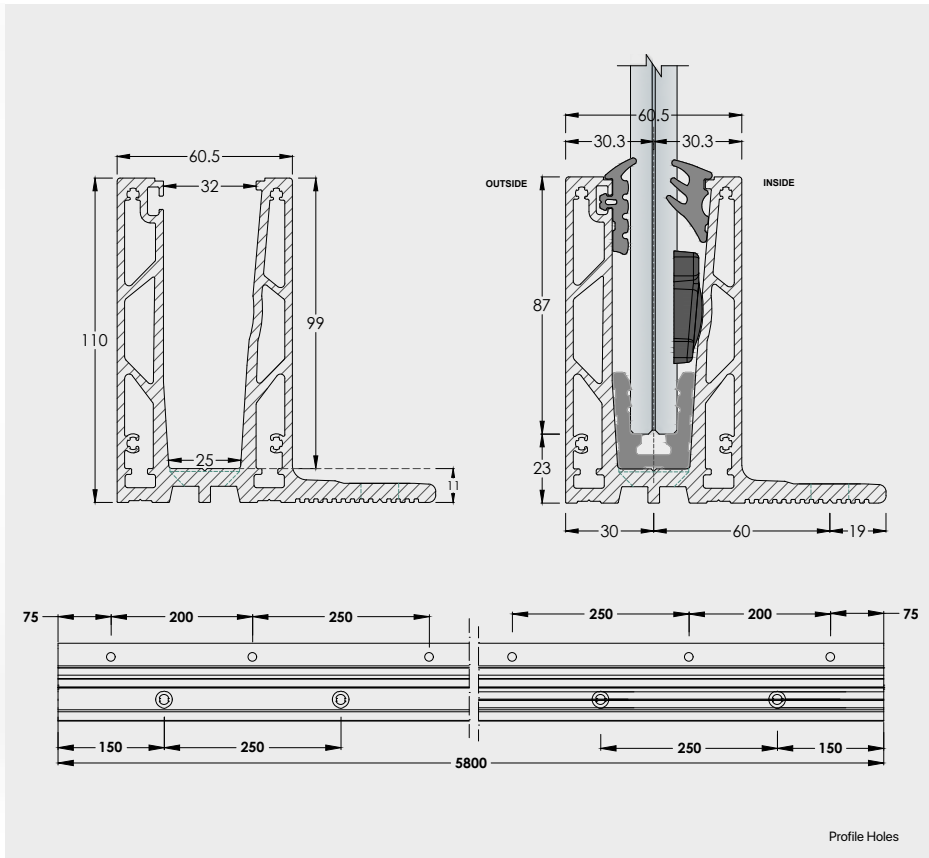









RAILING BASE



Profile data

Product Code	Material	Finish	Length (mm)	Weight (kg/m)	Max Height (m)	Max Load (KN)	Glass Thickness
GM01-S	Aluminium	Satin	5800	6,232	1,2	1	13,52 - 17,52 - 21,52
GM01-S	Aluminium	Natural Anodize	5800	6,232	1,2	1	13,52 - 17,52 - 21,52

System components

13,52	Glass Thickness	GM01-12A 	GM01-12B 	GM01-12C 	GM01SF-12 
17,52	Glass Thickness	GM01-16A 	GM01-16B 	GM01-16C 	GM01SF-16 
21,52	Glass Thickness	GM01-20A 	GM01-20B 	GM01-20C 	GM01SF-20 

Sets/bar

						
Length: 6m	Length: 6m	Length: 6m	2X10 pieces	23 pieces	24 pieces	GM01-SEC (OPTIONAL)
30m Roll Unit		14m Roll Unit				

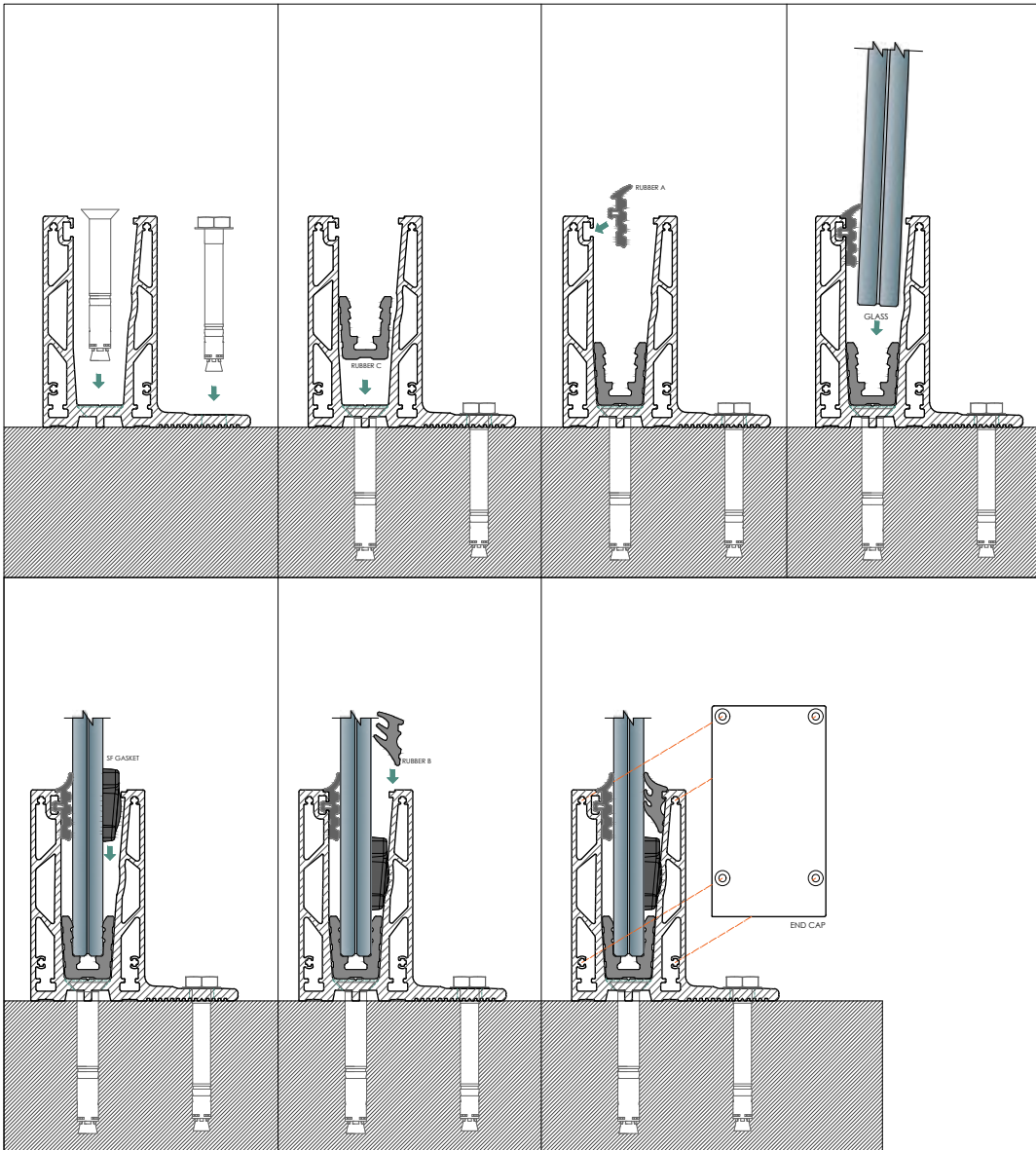

M11

GM01-S
TOP MOUNTED

M12 | RAILING BASE

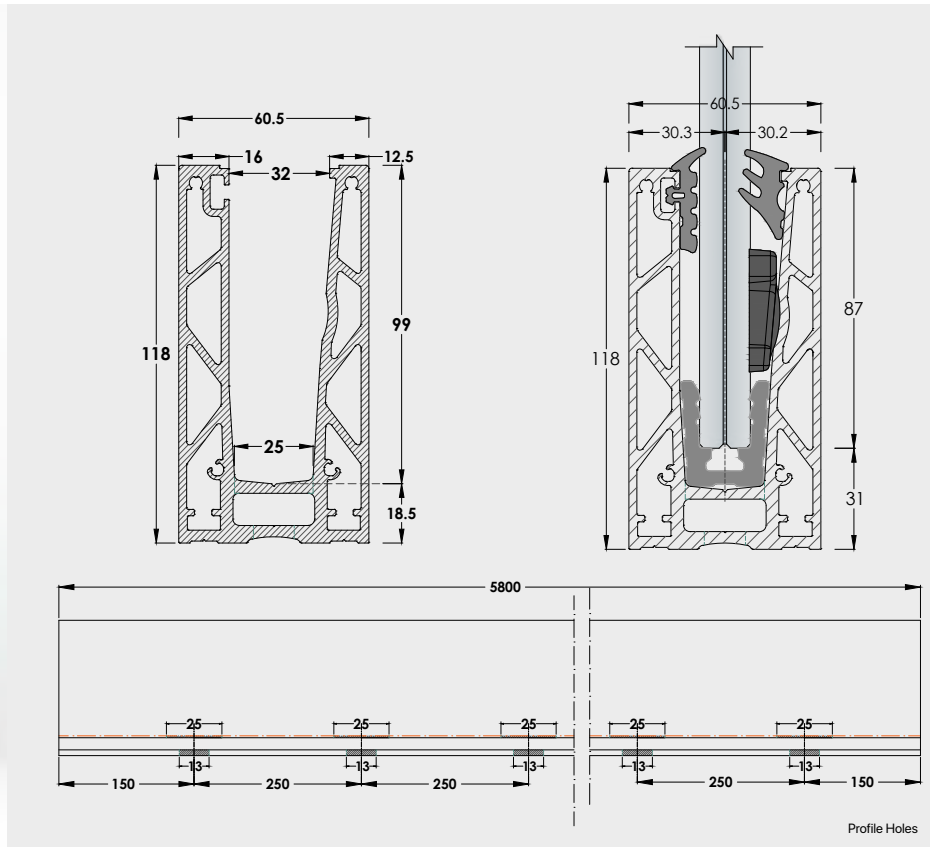

Profile data							
Product Code	Material	Finish	Length (mm)	Weight (kg/m)	Max Height (m)	Max Load (KN)	Glass Thickness
GM08	Aluminium	Satin	5800	5,389	1,1	1	13,52 - 17,52 - 21,52
GM08	Aluminium	Natural Anodize	5800	5,389	1,1	1	13,52 - 17,52 - 21,52

System components							
13,52	Glass Thickness	GM01-12A	GM01-12B	GM01-12C	GM01SF-12		
17,52	Glass Thickness	GM01-16A	GM01-16B	GM01-16C	GM01SF-16		
21,52	Glass Thickness	GM01-20A	GM01-20B	GM01-20C	GM01SF-20		

Sets/bar					
Length: 6m	Length: 6m	Length: 6m	2X10 pieces	23 pieces	GM08EC (OPTIONAL)
30m Roll Unit		14m Roll Unit			

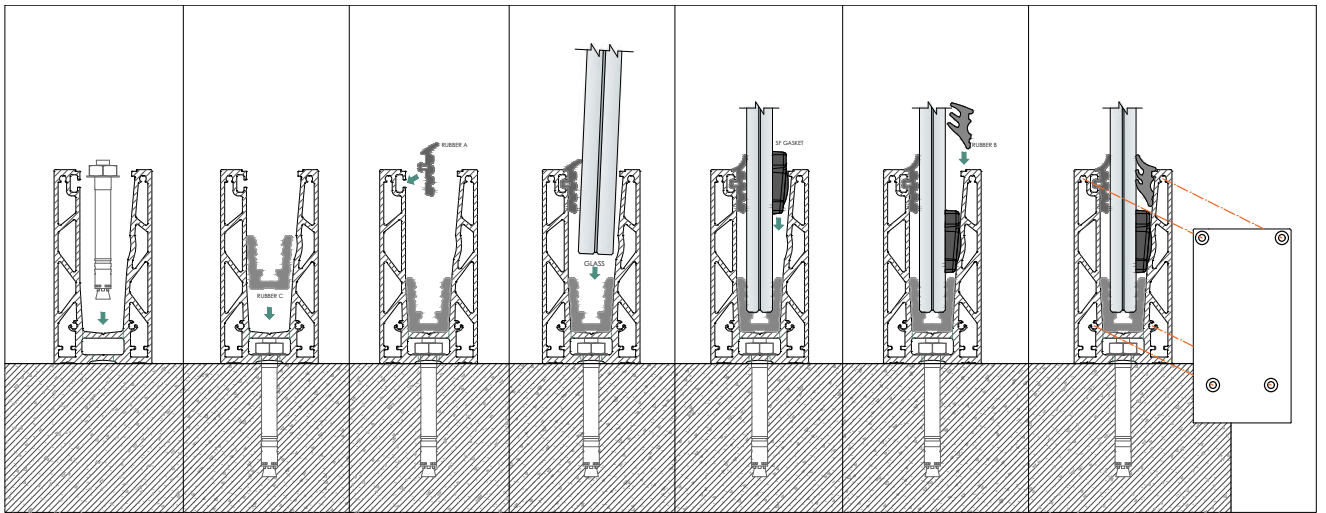

M12

GM08
TOP MOUNTED



M17 | RAILING BASE

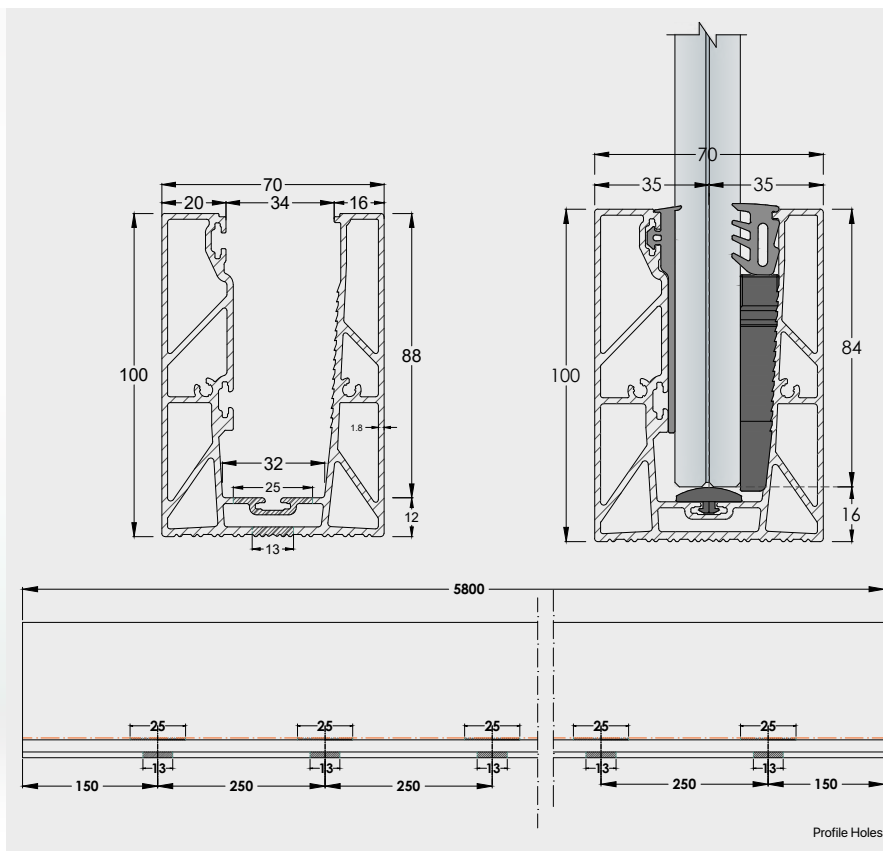
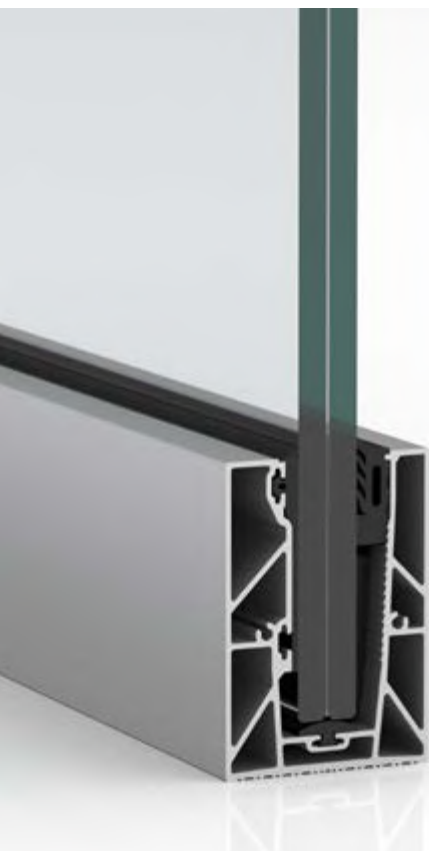

Profile data							
Product Code	Material	Finish	Length (mm)	Weight (kg/m)	Max Height (m)	Max Load (KN)	Glass Thickness
GM11	Aluminium	Satin	5800	3,700	1	1	13,52 - 17,52
GM11	Aluminium	Natural Anodize	5800	3,700	1	1	13,52 - 17,52

System components										
13,52	Glass Thickness	GM11-12		GM11B		GM11-2		5mm adjustment block	GM11SF	
17,52	Glass Thickness	GM11-16		GM01-16B		GM11-2		5mm adjustment block	GM11SF	

Sets/bar					
Length: 6m	Length: 6m	12 pieces	2X10 pieces	23 pieces	GM11EC (OPTIONAL)
30m Roll Unit					

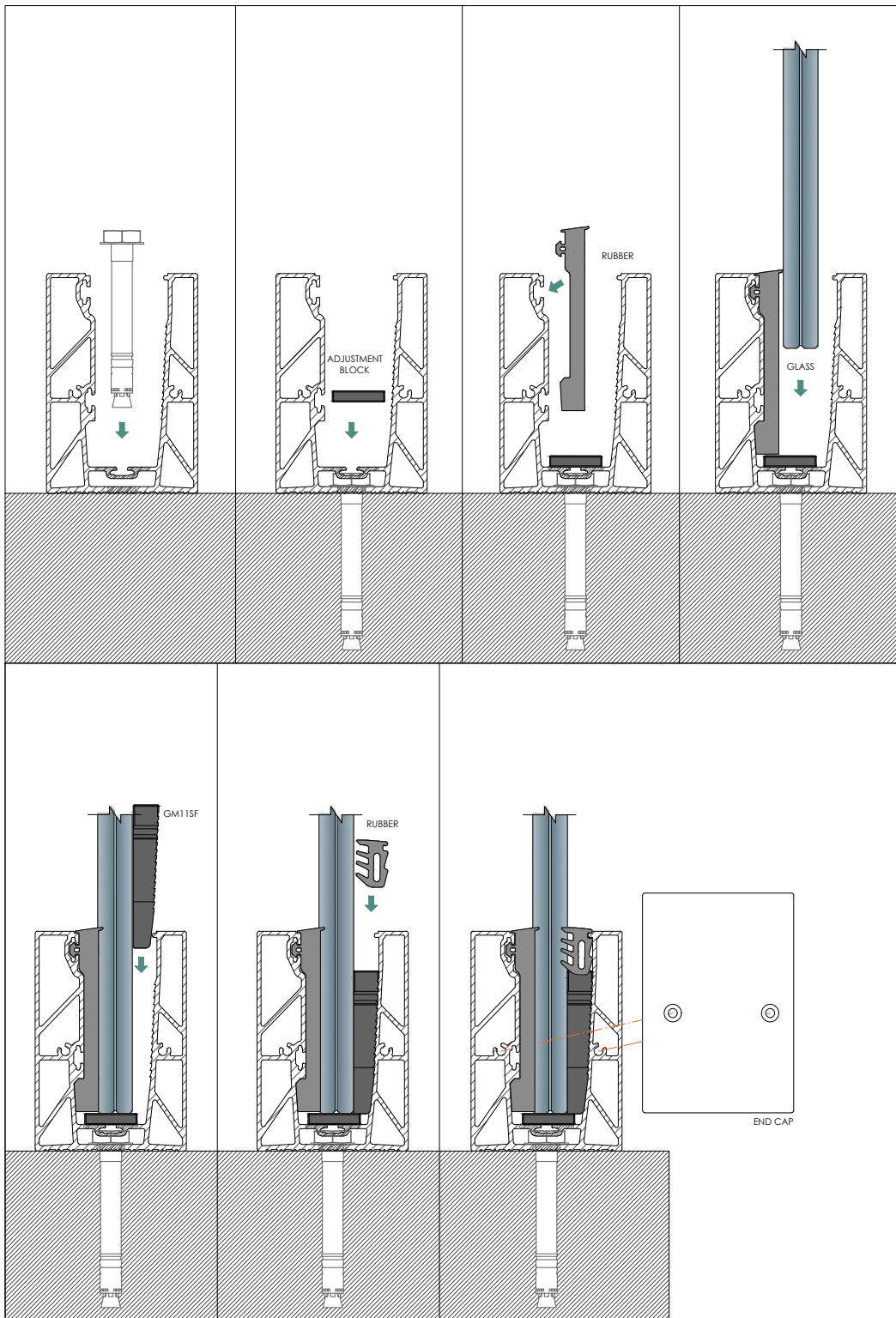

M17

GM11
TOP MOUNTED

M18 | RAILING BASE

NEW

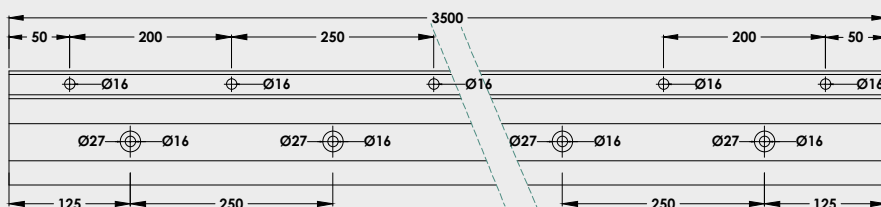
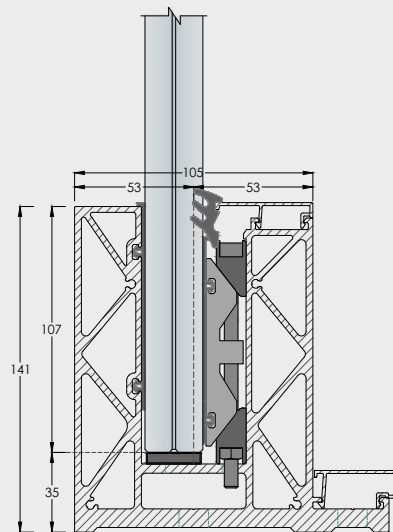
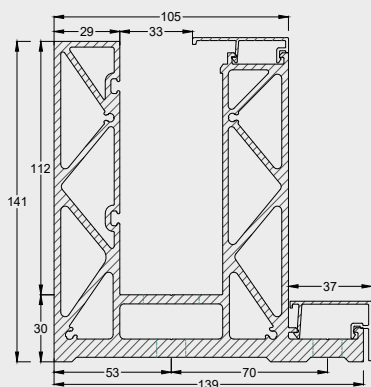
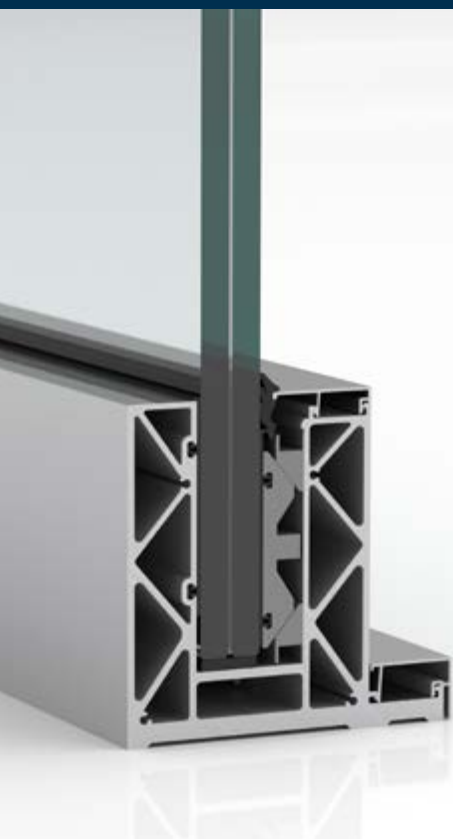

Profile Holes

Profile data

Product Code	Material	Finish	Length (mm)	Weight (kg/m)	Max Height (m)	Max Load (KN)	Glass Thickness
GM12	Aluminium	Satin	3500	11,163	1,2	3	21,52 - 25,52
GM12	Aluminium	Natural Anodize	3500	11,163	1,2	3	21,52 - 25,52

System components

21,52	Glass Thickness					
		GM12-24	GM12-20	GG11A	5mm adjustment block	GM12-5
25,52	Glass Thickness					
		GM12-24		GG11A	5mm adjustment block	GM12-5

Sets/bar

Length: 3500	Length: 3500	Length: 3500	8 pieces	12 pieces	29 pieces	GM12EC (OPTIONAL)
30m Roll Unit						

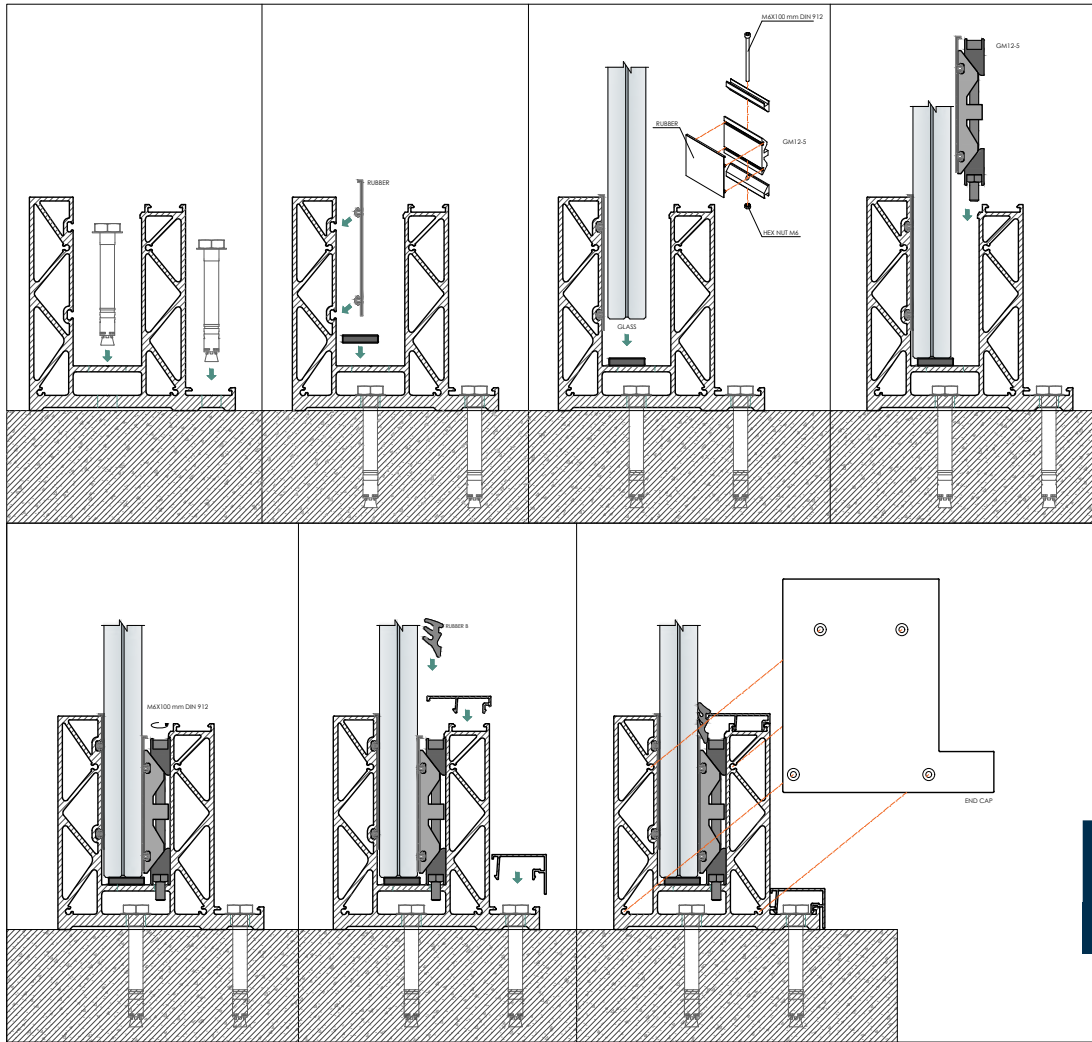

M18

GM12
TOP MOUNTED

3 kN MAXIMUM LOAD

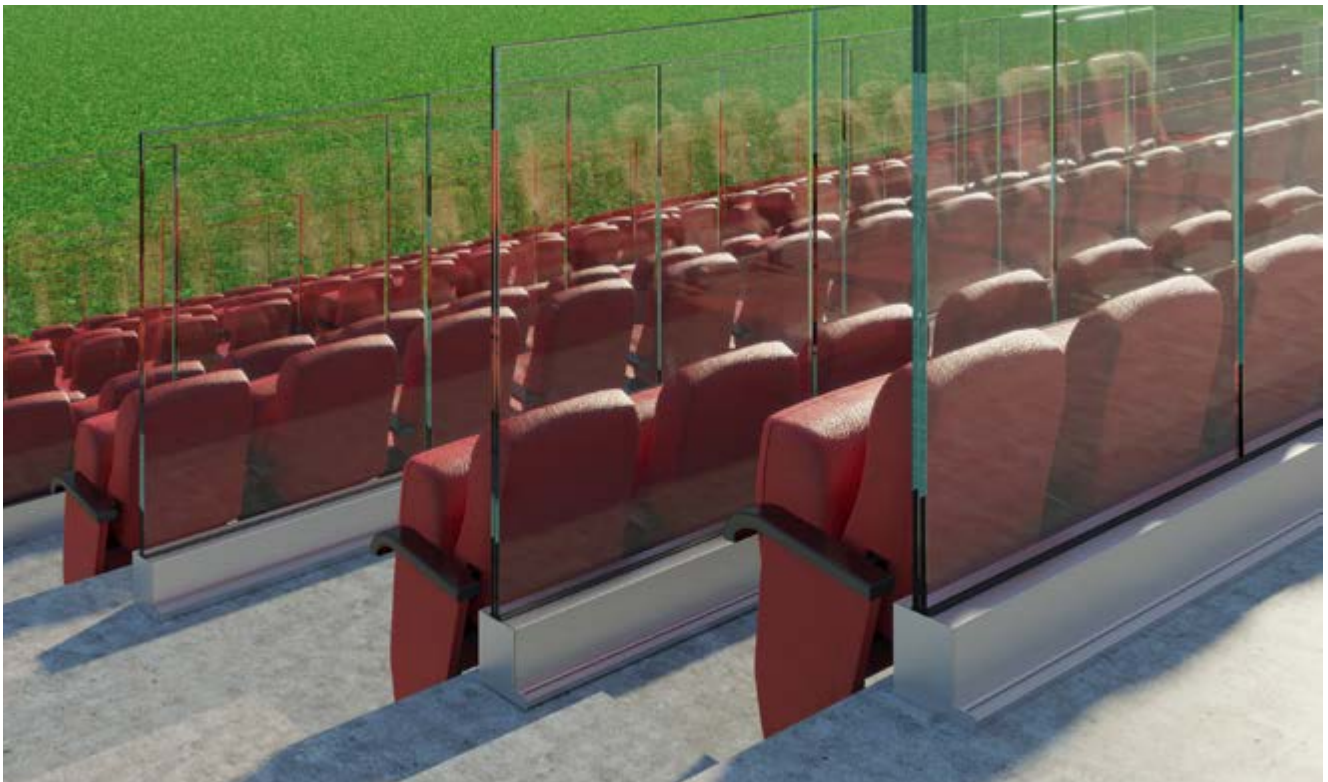

M19 | RAILING BASE

NEW

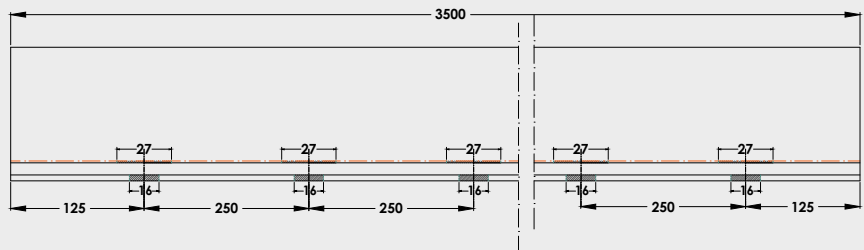
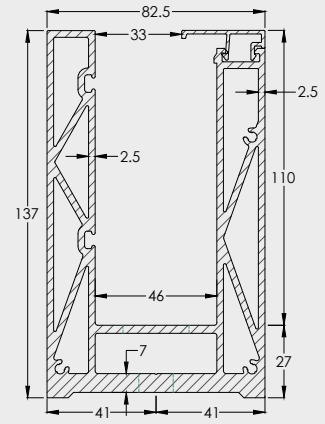
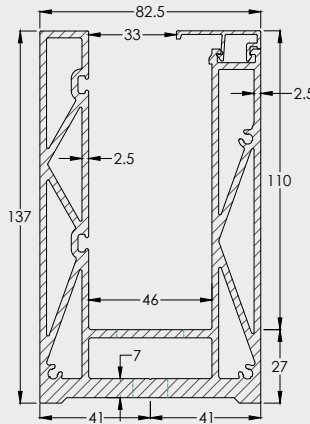









Profile Holes

Profile data

Product Code	Material	Finish	Length (mm)	Weight (kg/m)	Max Height (m)	Max Load (KN)	Glass Thickness
GM13	Aluminium	Satin	3500	7,126	1,2	2	21,52 - 25,52
GM13	Aluminium	Natural Anodize	3500	7,126	1,2	2	21,52 - 25,52

System components

21,52	Glass Thickness					
		GM12-24	GM12-20	GM01-12B	5mm adjustment block	GM12-5
25,52	Glass Thickness					
		GM12-24		GM01-16B	5mm adjustment block	GM12-5

Sets/bar

						
Length: 3500	Length: 3500	Length: 3500	8 pieces	12 pieces	14 pieces	GM13EC (OPTIONAL)
30m Roll Unit						

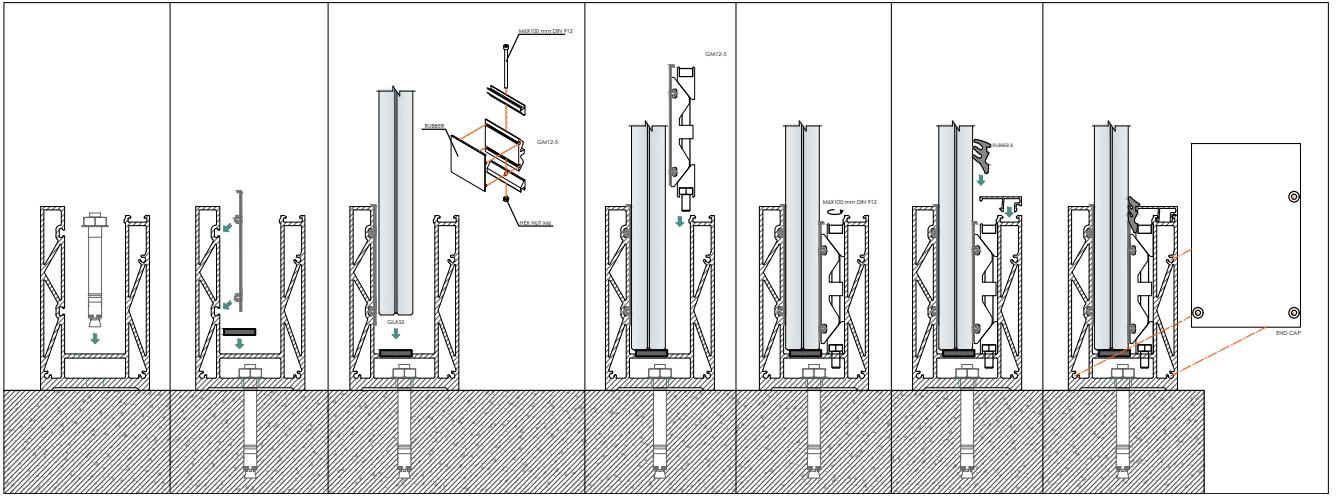

2 kN MAXIMUM LOAD

M19
GM13
TOP MOUNTED







GLASS RAILING BASES - LATERAL FIXING

M4 | RAILING SYSTEM

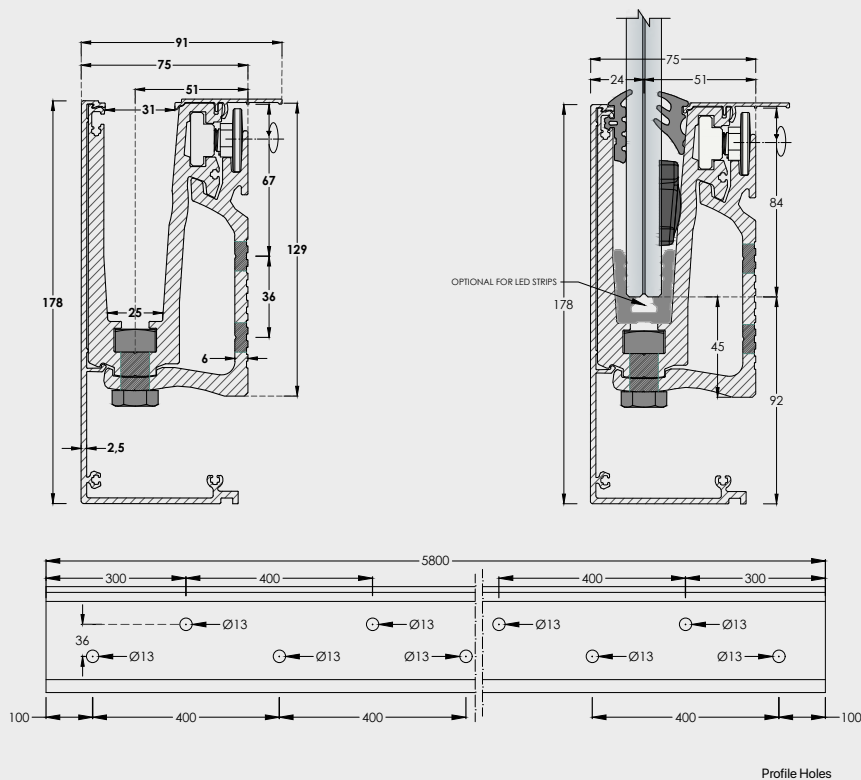

Profile data

Product Code	Material	Finish	Length (mm)	Weight (kg/m)	Max Height (m)	Max Load (KN)	Glass Thickness
GM04	Aluminium	Satin	5800	11,435	1,1	1	13,52 - 17,52 - 21,52
GM04	Aluminium	Natural Anodize	5800	11,435	1,1	1	13,52 - 17,52 - 21,52

System components

13,52	Glass Thickness	GM01-12A	GM01-12B	GM01-12C	GM04SD	GM04SC	GM01SF-12
17,52	Glass Thickness	GM01-16A	GM01-16B	GM01-16C	GM04SD	GM04SC	GM01SF-16
21,52	Glass Thickness	GM01-20A	GM01-20B	GM01-20C	GM04SD	GM04SC	GM01SF-20

Sets/bar

Length: 6m	Length: 6m	Length: 6m	2X10 pieces	23 pieces	12 pieces	29 pieces	GM04EC (OPTIONAL)
30m Roll Unit		14m Roll Unit					

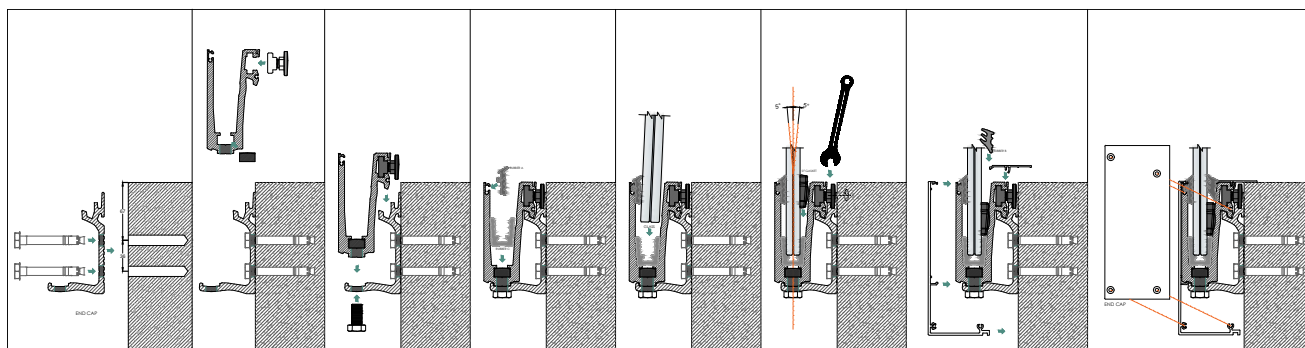

Adjust

- | | | |
|--------|-------|--------|
| 100 cm | ————— | 3,1 cm |
| 110 cm | ————— | 3,5 cm |
| 120 cm | ————— | 3,9 cm |

M4
GM04
LATERAL

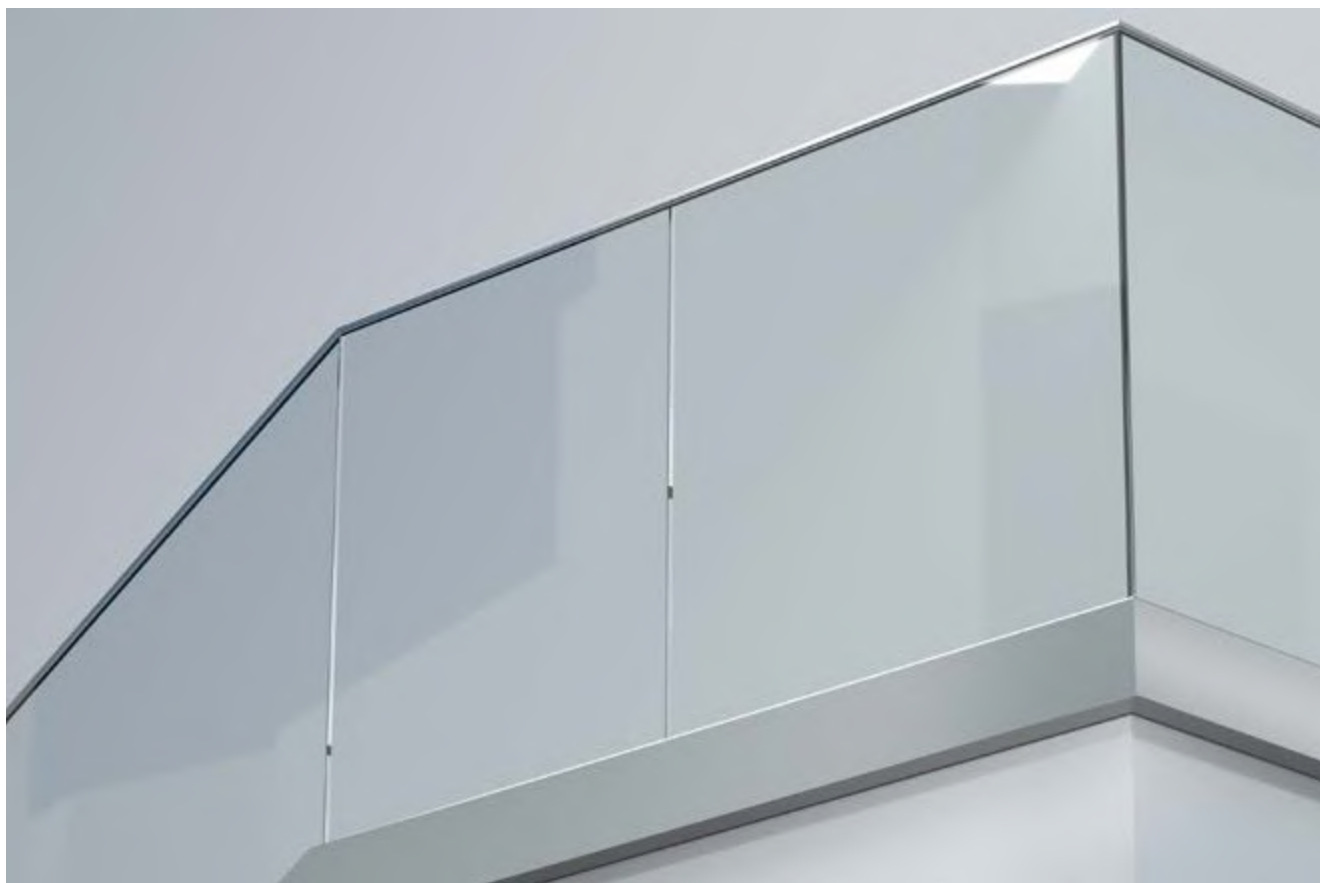



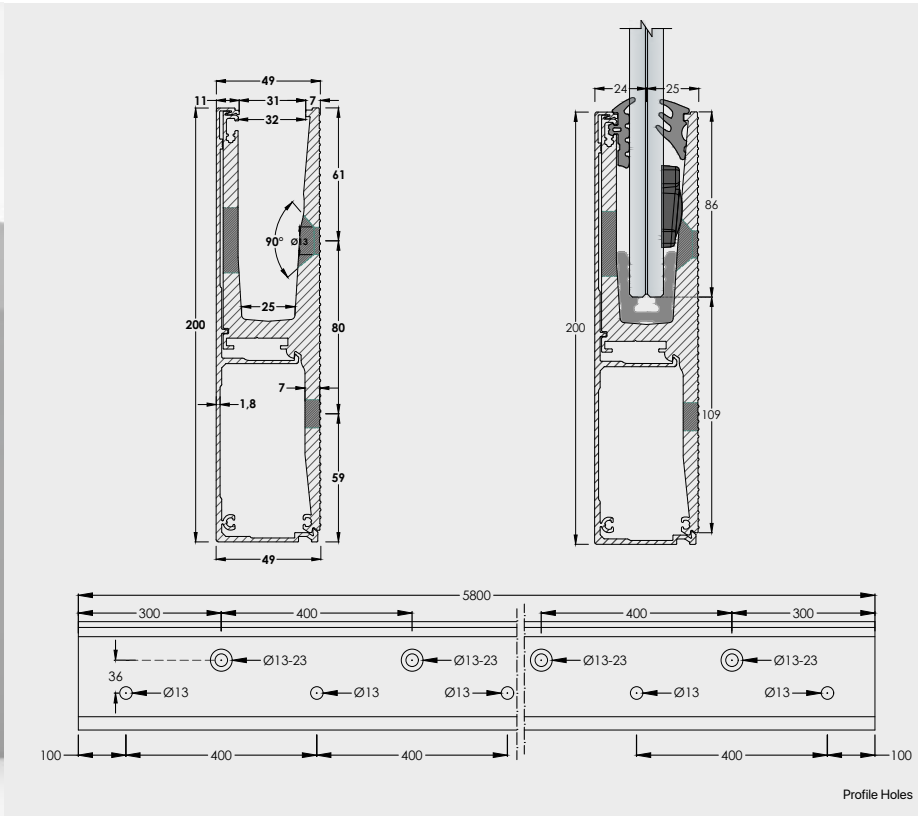









M13 | RAILING SYSTEM



Profile data

Product Code	Material	Finish	Length (mm)	Weight (kg/m)	Max Height (m)	Max Load (KN)	Glass Thickness
GM06	Aluminium	Satin	5800	8,669	1,1	1	13,52 - 17,52 - 21,52
GM06	Aluminium	Natural Anodize	5800	8,669	1,1	1	13,52 - 17,52 - 21,52

System components

13,52	Glass Thickness	GM01-12A 	GM01-12B 	GM01-12C 	GM01SF-12 
17,52	Glass Thickness	GM01-16A 	GM01-16B 	GM01-16C 	GM01SF-16 
21,52	Glass Thickness	GM01-20A 	GM01-20B 	GM01-20C 	GM01SF-20 

Sets/bar

						
Length: 6m	Length: 6m	Length: 6m	2X10 pieces	15 pieces	14 pieces	GM06EC (OPTIONAL)
30m Roll Unit		14m Roll Unit				

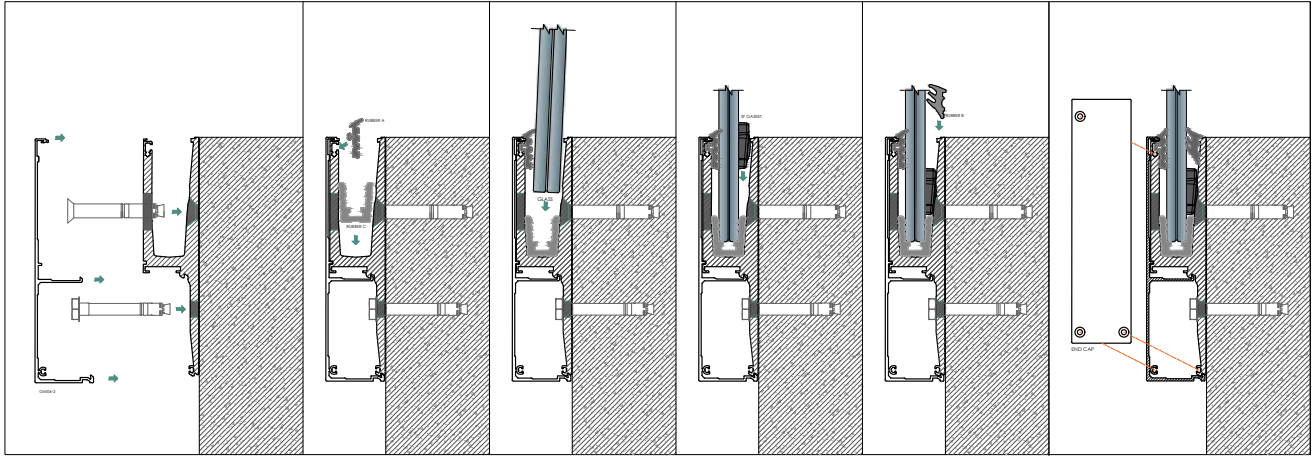

M13

GM06
LATERAL

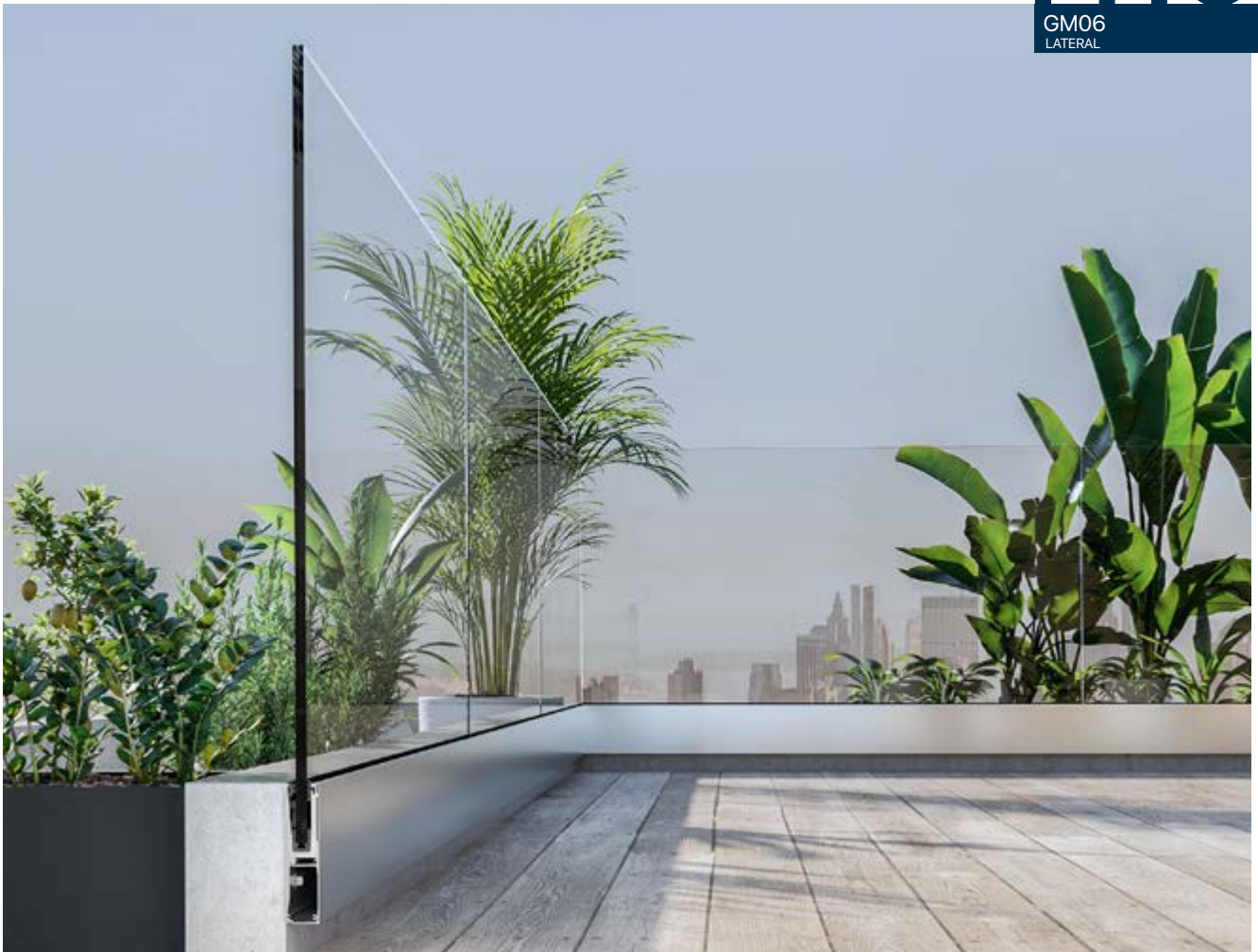

M14 | RAILING SYSTEM

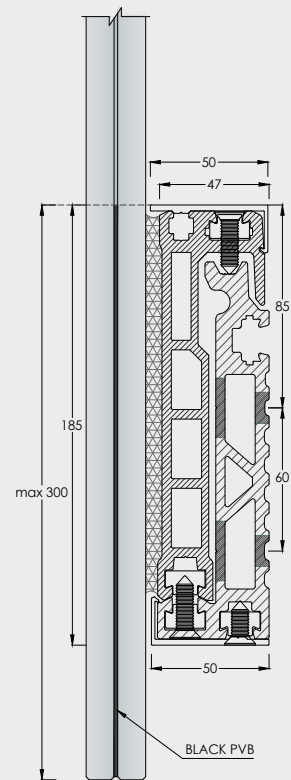
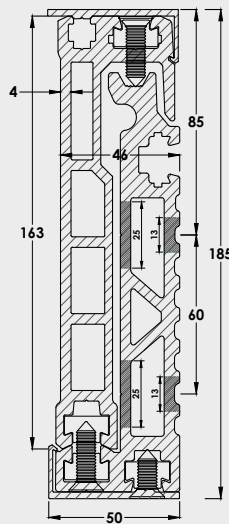
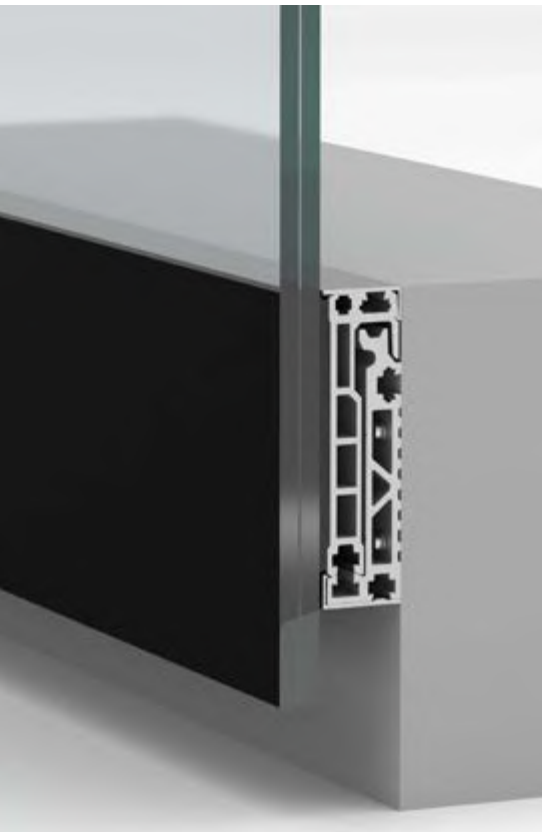

Profile data

Product Code	Material	Finish	Length (mm)	Weight (kg/m)	Max Height (m)	Max Load (KN)	Glass Thickness
GM07-1	Aluminium	Mill	5800	4,700	1,1	1	17,52 - 21,52
GM07-2	Aluminium	Mill	5800	5,515	1,1	1	17,52 - 21,52
GM07-3	Aluminium	Satin	5800	0,460	1,1	1	17,52 - 21,52
GM07-3	Aluminium	Natural Anodize	5800	0,460	1,1	1	17,52 - 21,52

Sets/bar

60 pieces	15X136 39 pieces	GM07EC (OPTIONAL)

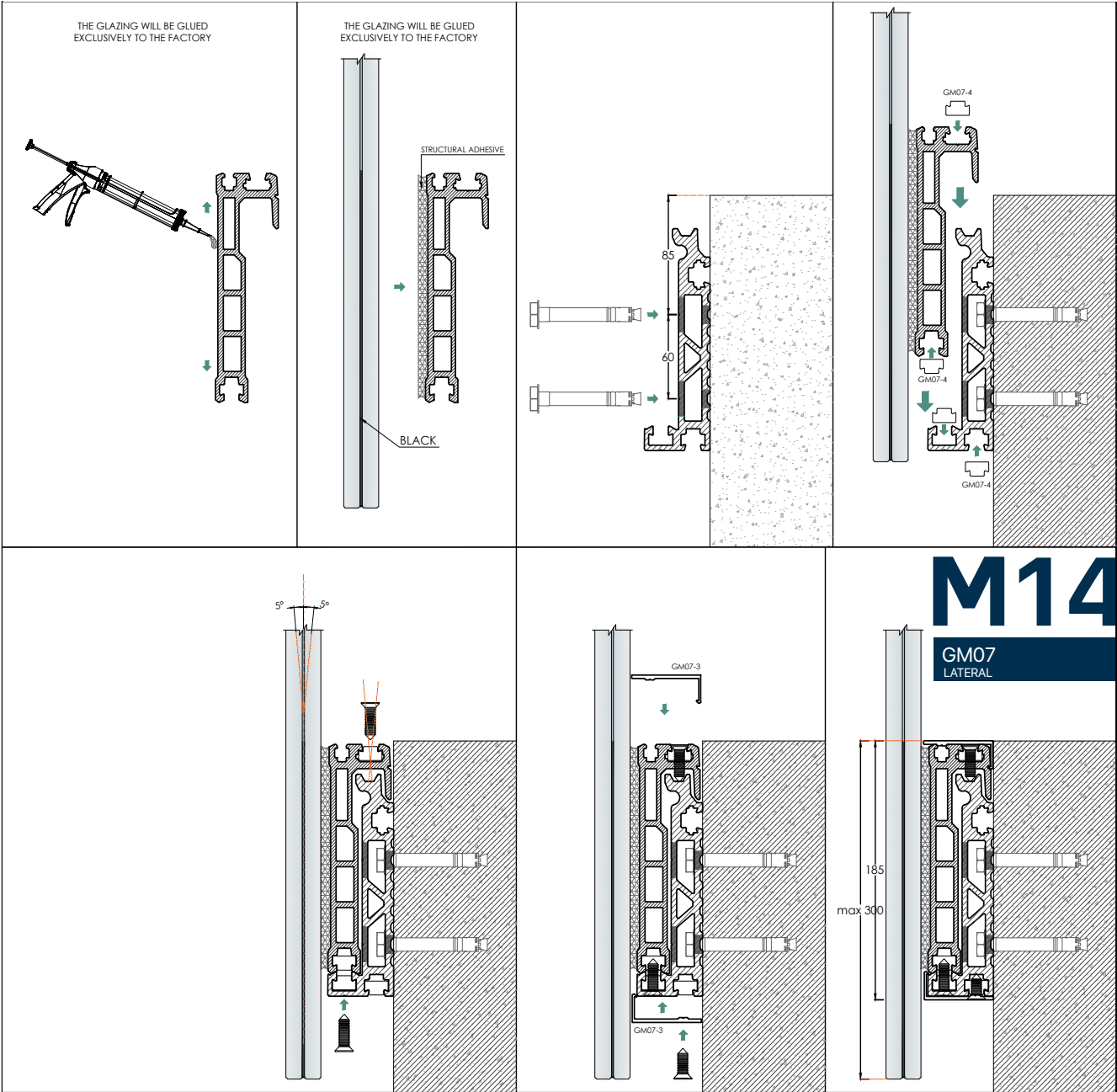

M20 | RAILING SYSTEM

NEW

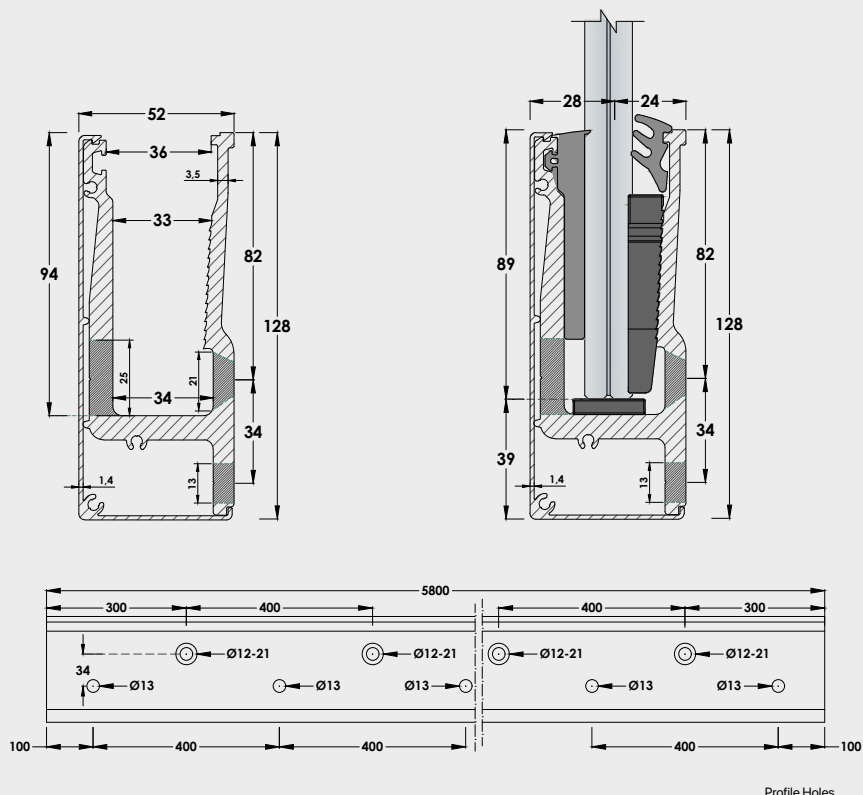

Profile data

Product Code	Material	Finish	Length (mm)	Weight (kg/m)	Max Height (m)	Max Load (KN)	Glass Thickness
GM14	Aluminium	Satin	5800	5,290	1,1	1	17,52 - 21,52
GM14	Aluminium	Natural Anodize	5800	5,290	1,1	1	17,52 - 21,52

System components

17,52	Glass Thickness	GM14-16		GM01-20B		5mm adjustment block	GM11SF	
		GM14-20		GM01-20B		5mm adjustment block	GM11SF	

Sets/bar

Length: 6m	Length: 6m	12 pieces	2X10 pieces	15X136 15 pieces	14 pieces	GM14EC (OPTIONAL)
30m Roll Unit						

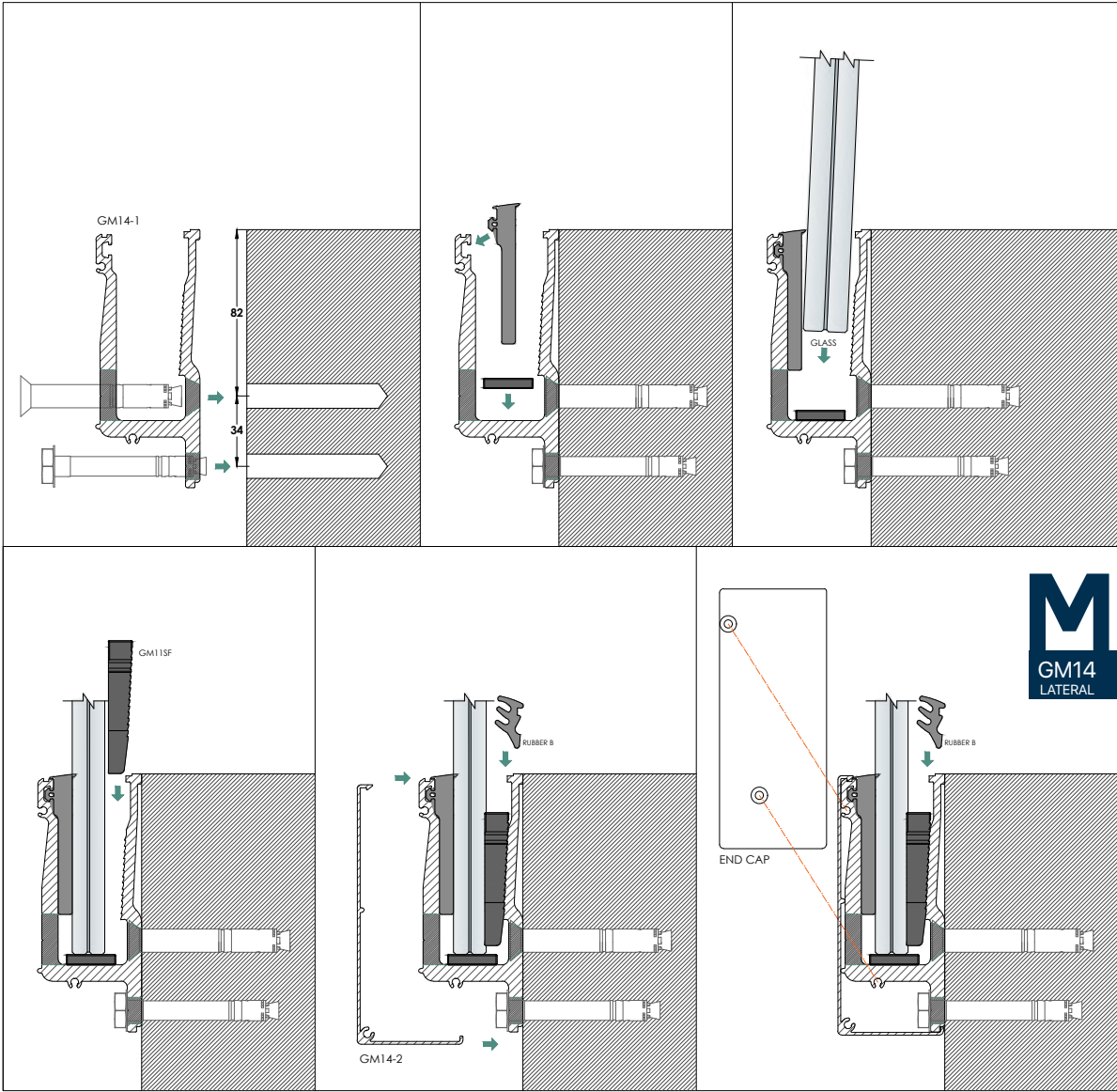

M20

GM14
LATERAL

M16 | FRENCH RAILING SYSTEM

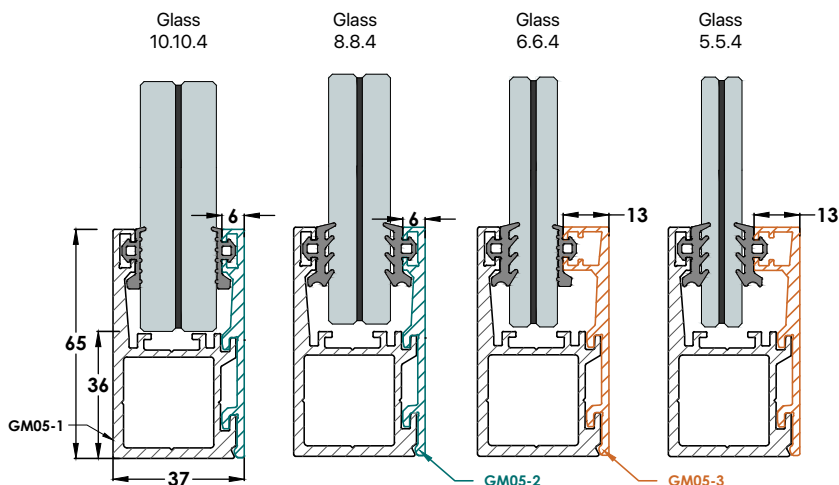

Profile data

Product Code	Material	Finish	Max Width (mm)	Weight (kg/m)	Max Height (m)	Max Load (KN)	Glass Thickness
GM05-1	Aluminium	Satin	2900	1,358	1,1	1	11,52 - 13,52 - 17,52 - 21,52
GM05-1	Aluminium	Natural Anodize	2900	1,358	1,1	1	11,52 - 13,52 - 17,52 - 21,52
GM05-2	Aluminium	Satin	2900	0,580	1,1	1	11,52 - 13,52 - 17,52 - 21,52
GM05-2	Aluminium	Natural Anodize	2900	0,580	1,1	1	11,52 - 13,52 - 17,52 - 21,52
GM05-3	Aluminium	Satin	2900	0,618	1,1	1	11,52 - 13,52 - 17,52 - 21,52
GM05-3	Aluminium	Natural Anodize	2900	0,618	1,1	1	11,52 - 13,52 - 17,52 - 21,52

Sets/bar

GM05-8A kit

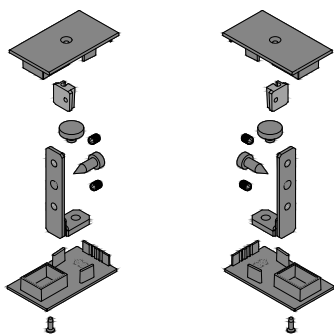

GM05A



GM05B

PCA-GM05A | GM05B
Railing Profile Fixing Rubber
30m Roll | Unit



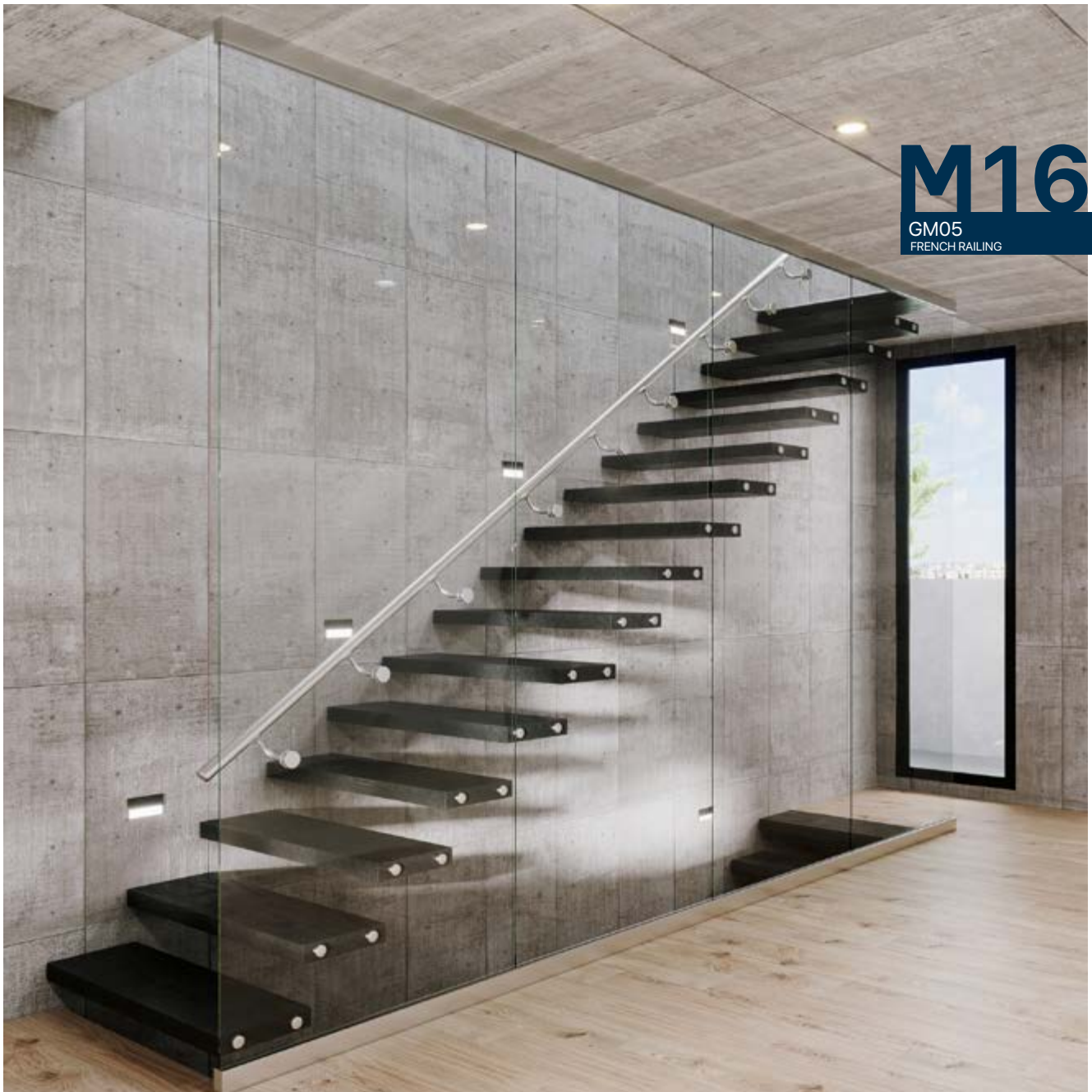
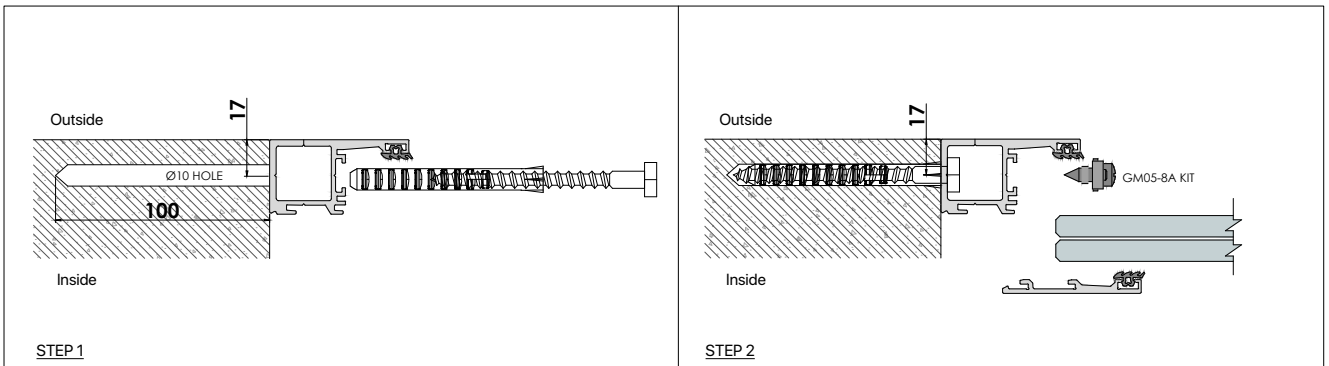

M15 | RAILING SYSTEM

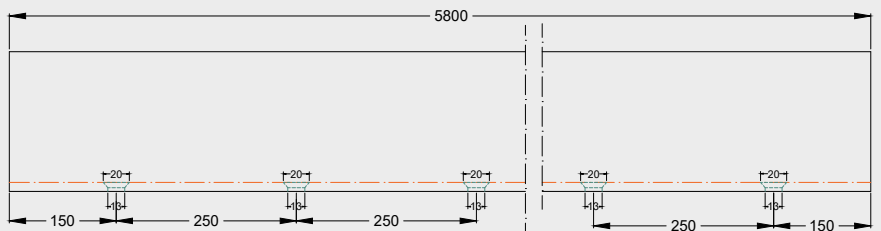
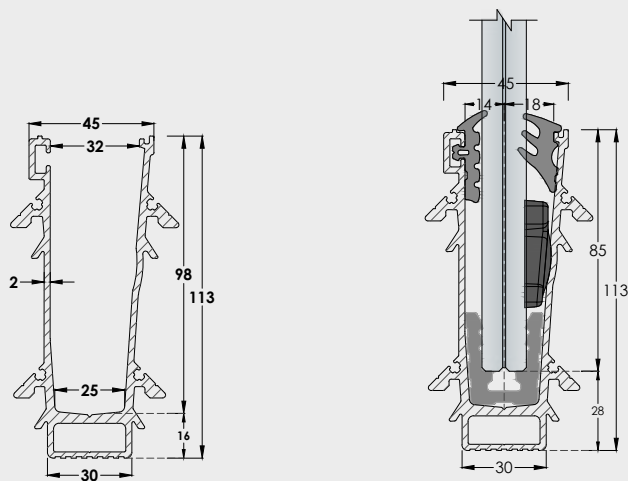













Profile Holes

Profile data

Product Code	Material	Finish	Length (mm)	Weight (kg/m)	Max Height (m)	Max Load (KN)	Glass Thickness
GM09	Aluminium	Satin	5800	2,944	1,1	1	13,52 - 17,52 - 21,52
GM09	Aluminium	Natural Anodize	5800	2,944	1,1	1	13,52 - 17,52 - 21,52

System components

13,52	Glass Thickness	GM01-12A 	GM01-12B 	GM01-12C 	GM01SF-12 
17,52	Glass Thickness	GM01-16A 	GM01-16B 	GM01-16C 	GM01SF-16 
21,52	Glass Thickness	GM01-20A 	GM01-20B 	GM01-20C 	GM01SF-20 

Sets/bar

					
Length: 5800	Length: 5800	Length: 5800	2X10 pieces	23 pieces	OPTIONAL END CAP
30m Roll Unit		14m Roll Unit			

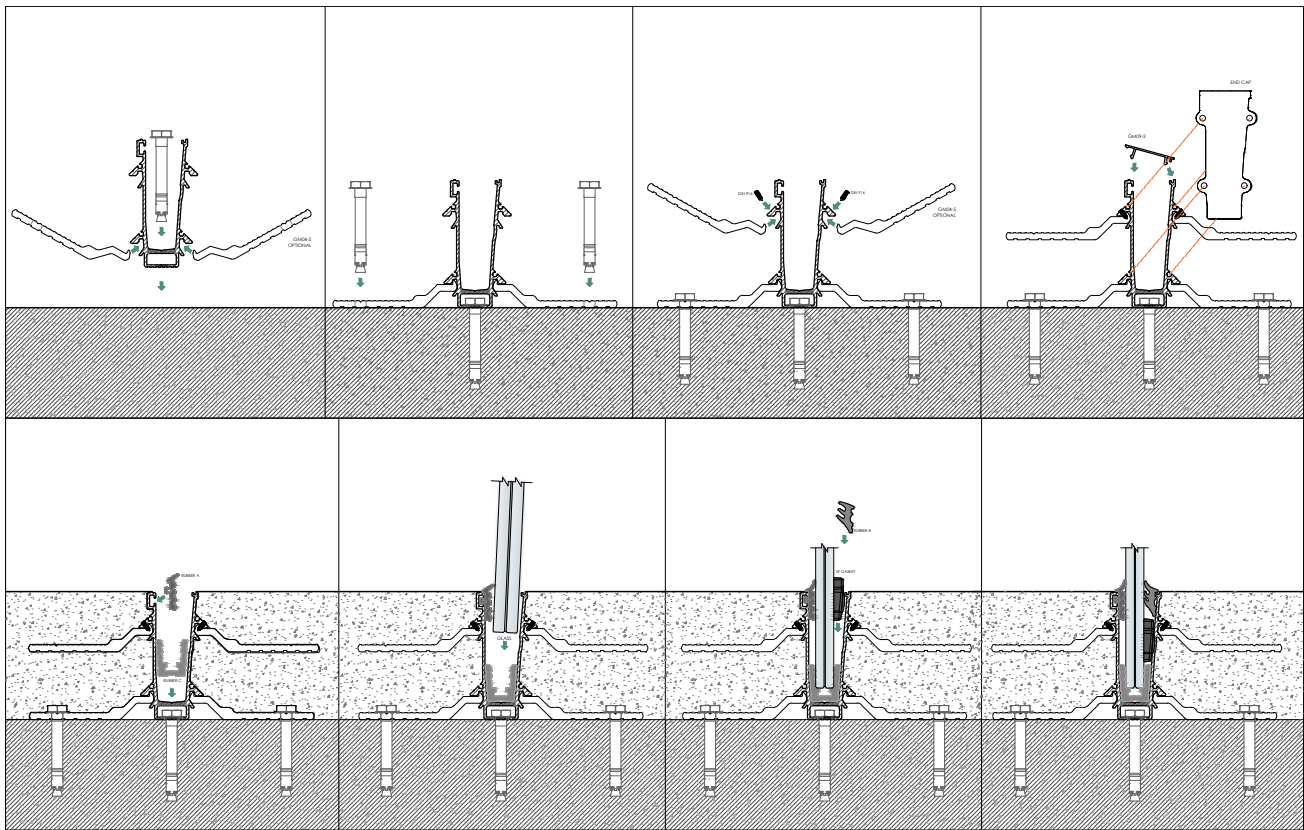

M15



GM09
CONCEALED

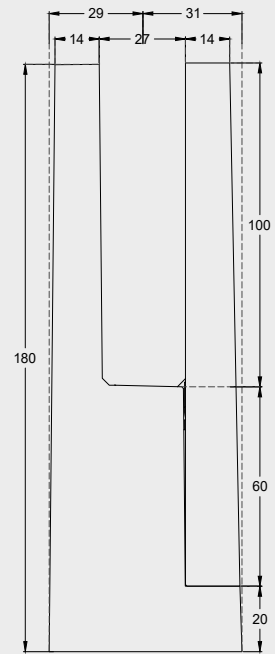

M9 | RAILING SYSTEM



Profile data						
Product Code	Material	Finish	Weight (kg/pc)	Max Height (m)	Max Load (KN)	Glass Thickness
BM12	Stainless Steel 304	Satin	2,242	1,1	1	13,52 - 17,52 - 21,52
BM12	Stainless Steel 316	Satin	2,242	1,1	1	13,52 - 17,52 - 21,52

Product components					
13,52	Glass Thickness	STEEL PLATES 1piece of 5 mm	+	1piece of 4 mm	 1piece
17,52	Glass Thickness	STEEL PLATES 1piece of 3 mm	+	1piece of 3 mm	 1piece
21,52	Glass Thickness	STEEL PLATES 1piece of 2 mm			 1piece

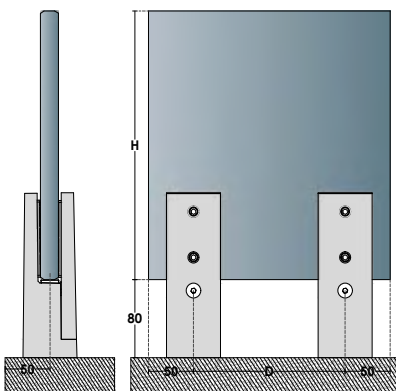



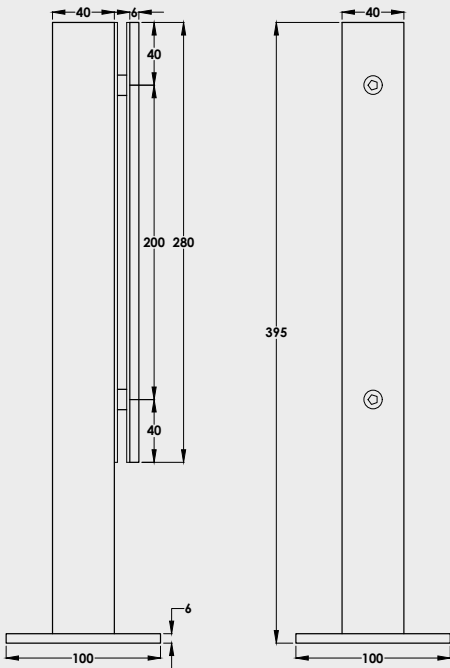

RAILING SYSTEM | M21

GLASS RAILINGS



Profile data						
Product Code	Material	Finish	Weight (kg/pc)	Max Height (m)	Max Load (KN)	Glass Thickness
BM13	Stainless Steel 304	Satin	1,608	1,1	1	11,52 - 13,52

Product components			
11,52	Glass Thickness	4 pieces	
13,52	Glass Thickness	4 pieces	

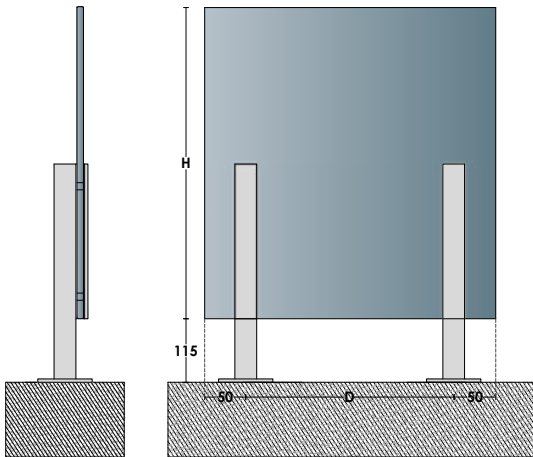

Max Dimensions						
	10mm			12mm		
H [mm]	900	1000	1100	900	1000	1100
D [mm]	800	700	600	800	700	600

M22 | RAILING SYSTEM

NEW

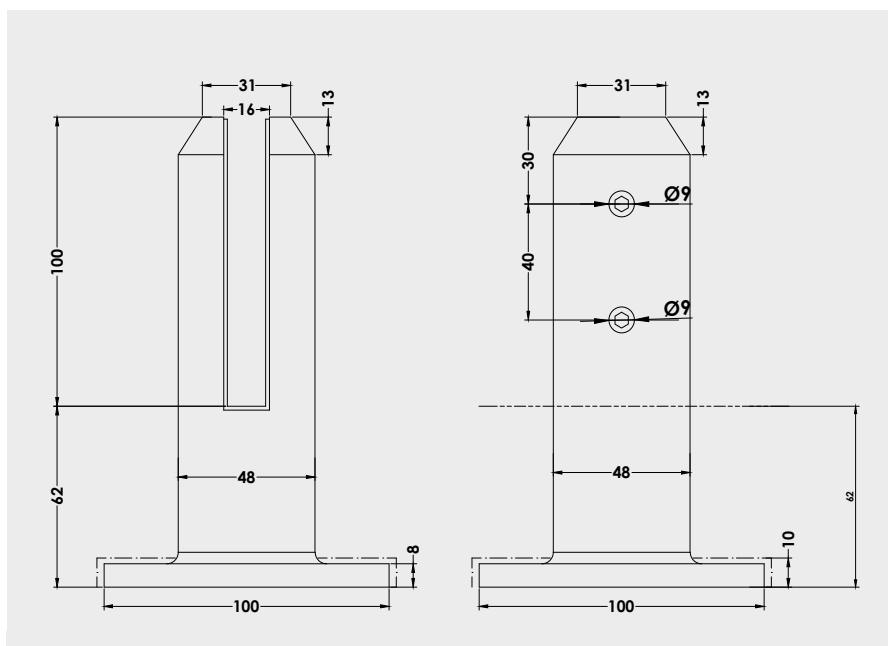

Profile data

Product Code	Material	Finish	Weight (kg/pc)	Max Height (m)	Max Load (KN)	Glass Thickness
BM14	Stainless Steel 304	Satin	1,084	1	1	11,52 - 13,52
BM14	Stainless Steel 316	Satin	1,084	1	1	11,52 - 13,52

Product components

11,52	Glass Thickness	4 pieces	
13,52	Glass Thickness	4 pieces	

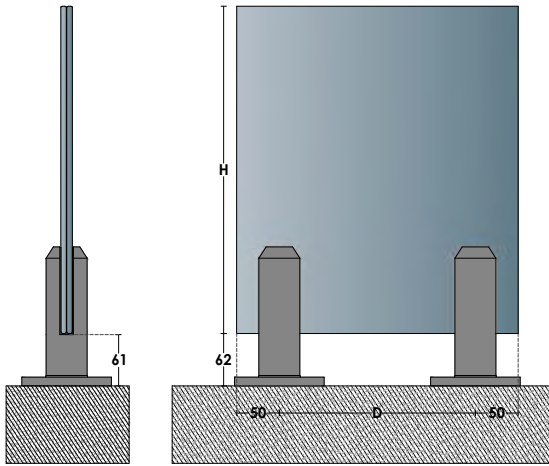

Max Dimensions						
	10mm			12mm		
H [mm]	900	1000	1100	900	1000	1100
D [mm]	800	700	600	800	700	600

M6 | LATERAL POINT FIXING SERIES



PCA-AN13
Ø60 Adjustable Anchor Spacer
 16,20mm | Glass Thickness
 120cm | Max. Height
 1KN | Max.Load
 Stainless Steel 304 | Material
 Satin | Finish

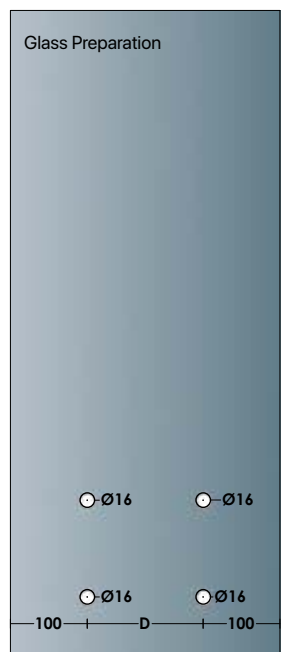
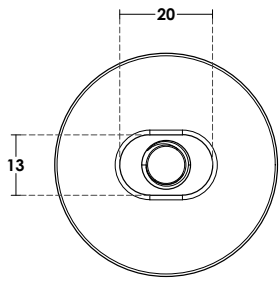
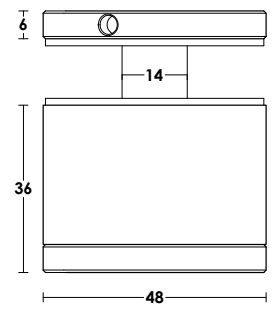
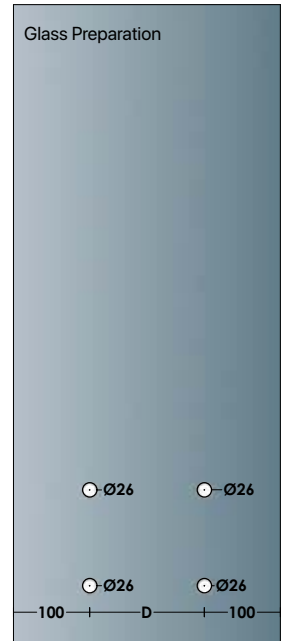
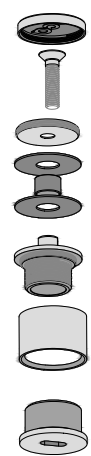
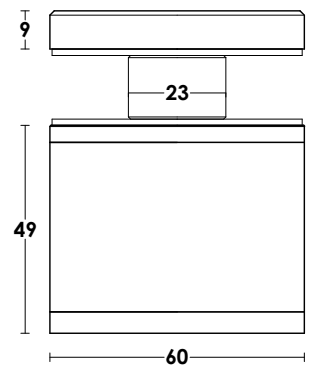
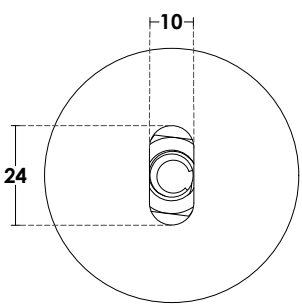

PCA-AN12
Ø48 Adjustable Anchor Spacer
 10-20 mm | Glass Thickness
 120cm | Max. Height
 1KN | Max.Load
 Stainless Steel 304 | Material
 Satin | Finish

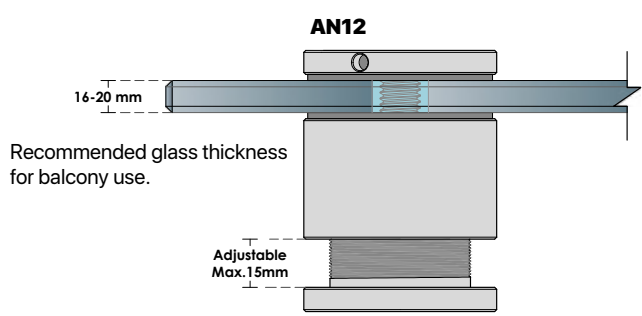

M6 | LATERAL POINT FIXING SERIES

PCA-AN01 | AN02 | AN03 | AN04 Ø48 Anchor Spacer

10-20 mm | Glass Thickness
120cm | Max. Height
1KN | Max. Load
Stainless Steel 304 | Material
Satin | Finish

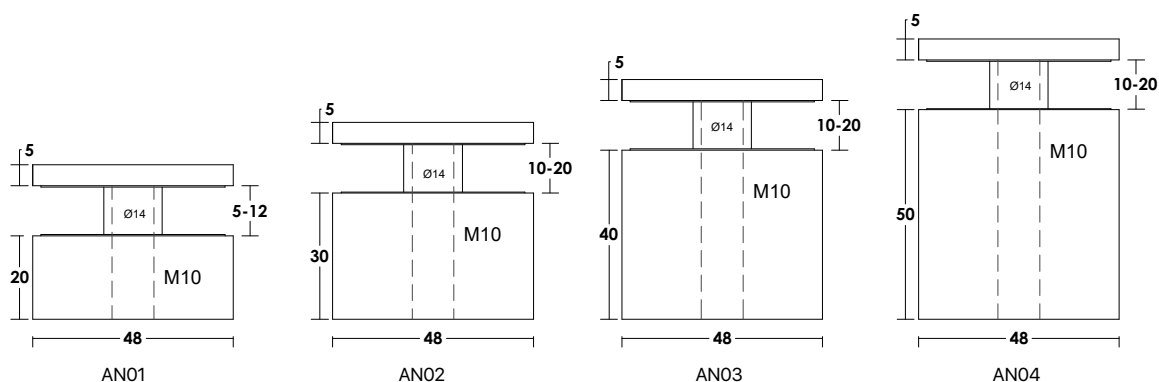

AN01

AN02

AN03

AN04

Ø 16 GLASS HOLE

AN04 available also in SS316

Ø 16 GLASS HOLE

PCA-AN05 | AN06 | AN07 | AN08 Ø38 Anchor Spacer

10-20 mm | Glass Thickness
120cm | Max. Height
0.5 KN | Max. Load
Stainless Steel 304 | Material
Satin | Finish

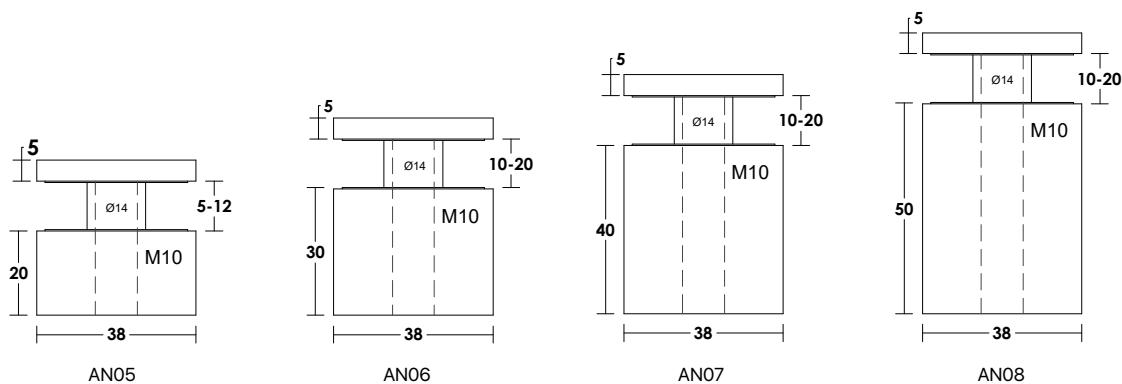

AN05

AN06

AN07

AN08

AN14

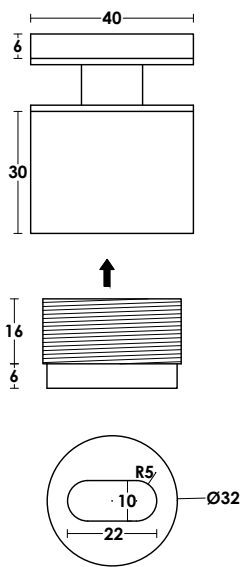

AN15

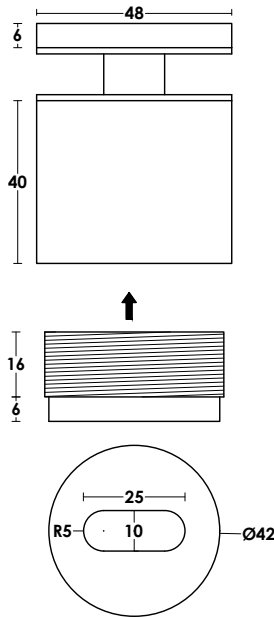

PCA-AN14 | AN15
Anchor Spacer

10-20 mm | Glass Thickness
1KN | Max.Load
Stainless Steel 304 | Material
Polished | Finish

NEW

GLASS RAILINGS

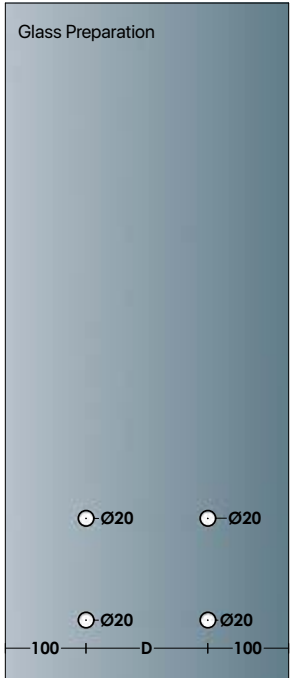

Glass Thickness		AN01-AN04			AN05-AN08			AN12			
16mm	H[mm]	1000	1100	1200	1000	1100	1200	1000	1100	1200	H[mm]
	C[mm]	125	150	150	125	150	150	125	150	150	C[mm]
	D[mm]	900	900	800	900	900	800	900	900	800	D[mm]
20mm	H[mm]	1000	1100	1200	1000	1100	1200	1000	1100	1200	H[mm]
	C[mm]	100	125	150	100	125	150	100	125	150	C[mm]
	D[mm]	900	900	800	900	900	800	900	900	800	D[mm]

M7 | LATERAL POINT FIXING SERIES



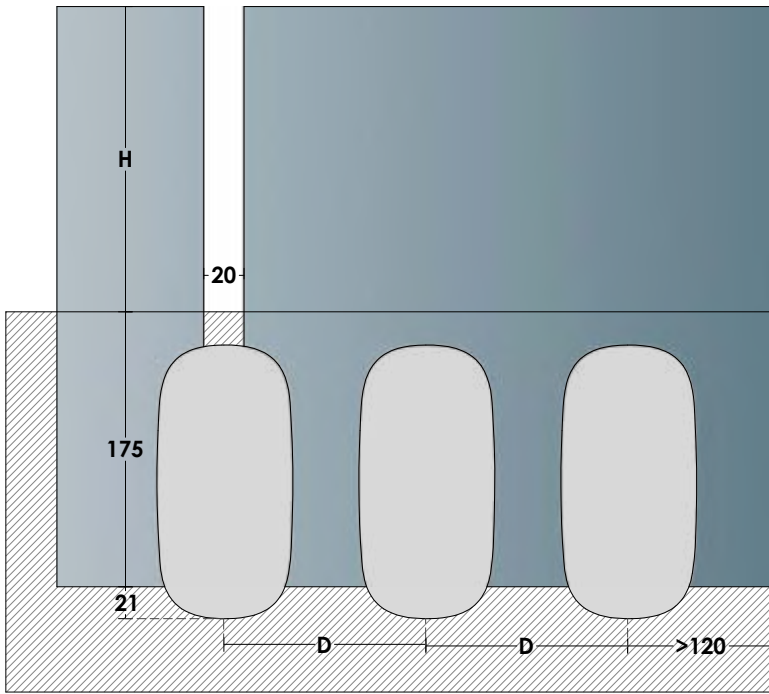

NO HOLES REQUIRED BETWEEN 2 GLASSES

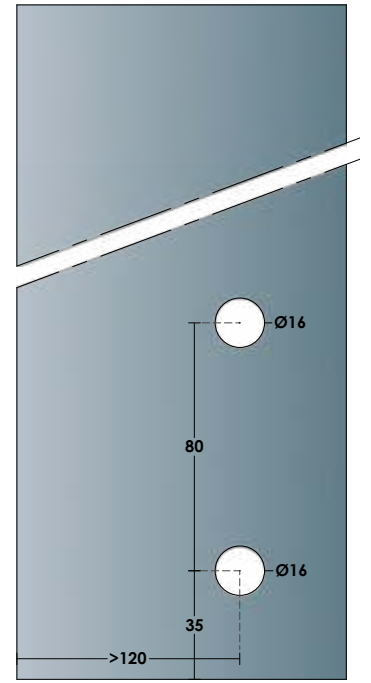

GLASS RAILINGS

M7

BM07
LATERAL

Class Thickness	BM07			
16mm	H[mm]	1000	1100	1200
	D[mm]	800	700	600
20mm	H[mm]	1000	1100	1200
	D[mm]	800	700	600

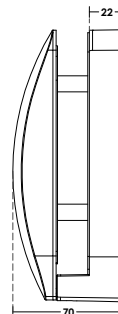
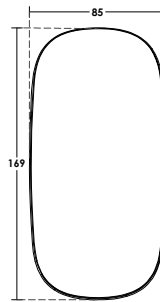
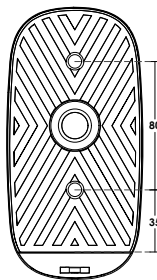

PCA-BM07
Lateral Base
16,20 mm | Glass Thickness
120cm | Max. Height
1KN | Max. Load
Stainless Steel 304 | Material
Satin | Finish

M8 | LATERAL POINT FIXING SERIES



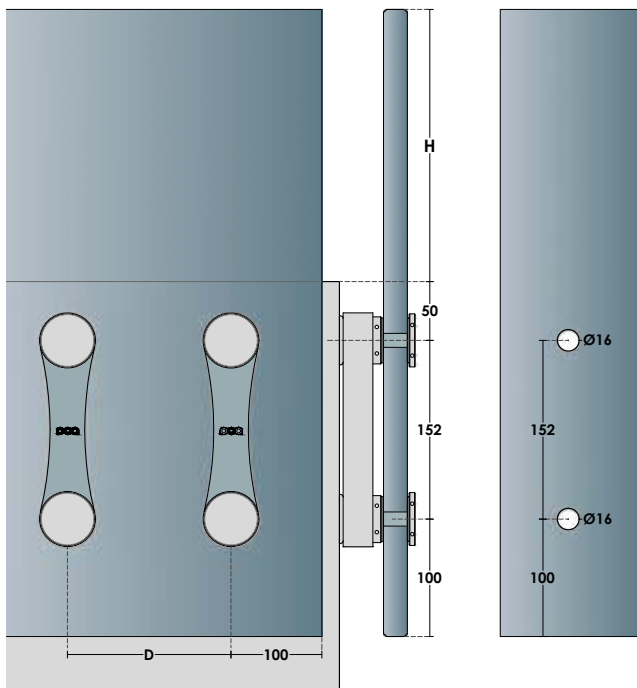

Glass Thickness	AN11			
16mm	H[mm]	1000	1100	1200
	D[mm]	800	700	600
20mm	H[mm]	1000	1100	1200
	D[mm]	800	700	600

M8

AN11
LATERAL

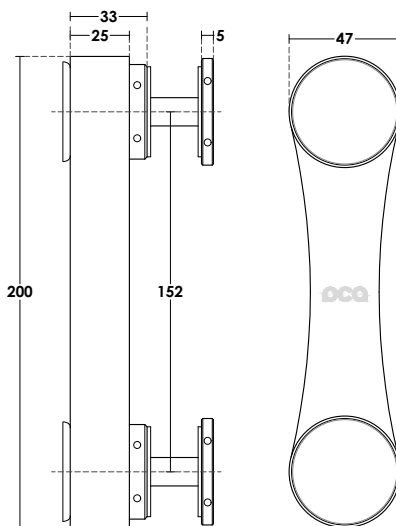

PCA-AN11
5 Axes Adjustable Double Anchor Spacer
 10-20 mm | Glass Thickness
 1KN | Max.Load
 Stainless Steel 304 | Material
 Satin | Finish

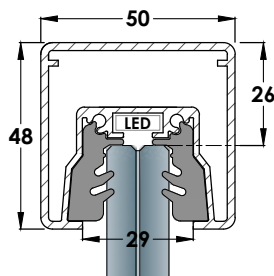

K002-16A K002-20A

PCA-K002

Handrail Profile

16,20 mm | Glass Thickness
1,368 kg | Weight/meter
580 cm | Length
Aluminium | Material
Natural Anodize, Satin | Finish



Railing Profile Fixing Rubber
30m Roll | Unit

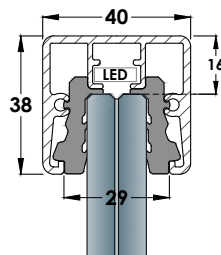

K002A-12A K002A-16A

PCA-K002A

Handrail Profile

12, 16 mm | Glass Thickness
0,903 kg | Weight/meter
580 cm | Length
Aluminium | Material
Natural Anodize, Satin | Finish



Railing Profile Fixing Rubber
30m Roll | Unit

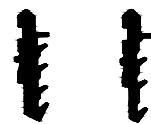
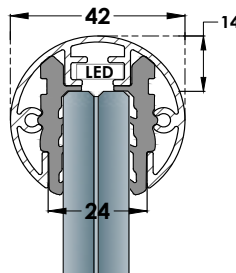

K003A-12A K003A-16A

PCA-K003A

Handrail Profile

12,16 mm | Glass Thickness
0,729 kg | Weight/meter
580 cm | Length
Aluminium | Material
Natural Anodize, Satin | Finish



Railing Profile Fixing Rubber
30m Roll | Unit

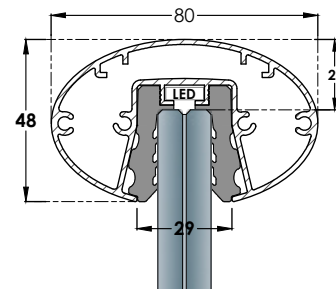

K004-16A

PCA-K004

Handrail Profile

16 mm | Glass Thickness
1,442 kg | Weight/meter
580 cm | Length
Aluminium | Material
Natural Anodize, Satin | Finish



Railing Profile Fixing Rubber
30m Roll | Unit

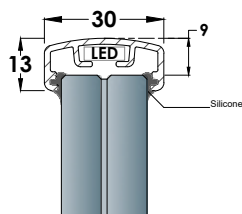

PCA-K005

Handrail Profile

10-20 mm | Glass Thickness
0,283 kg | Weight/meter
580 cm | Length
Aluminium | Material
Natural Anodize, Satin | Finish



Shower Cabins & WC Partitions	8
Doors & Office Partitions	81
Facades	169
Folding	199
Guillotine	209
Spiders	215
Balcony Railings	225
Inox Railings	273
Staircase	293
Canopies	297
Miscellaneous & Consumables	307

NX | INOX RAILINGS

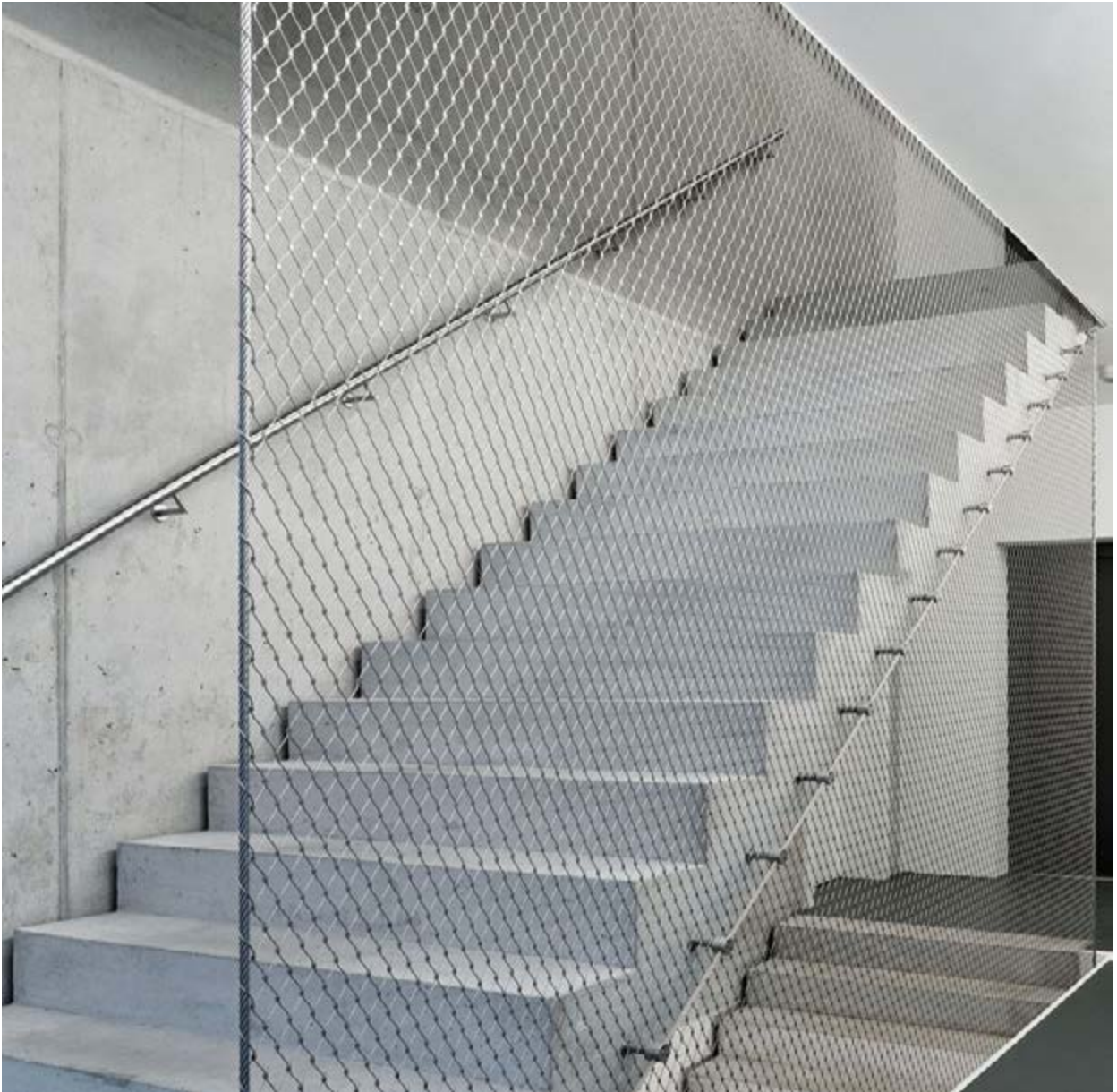

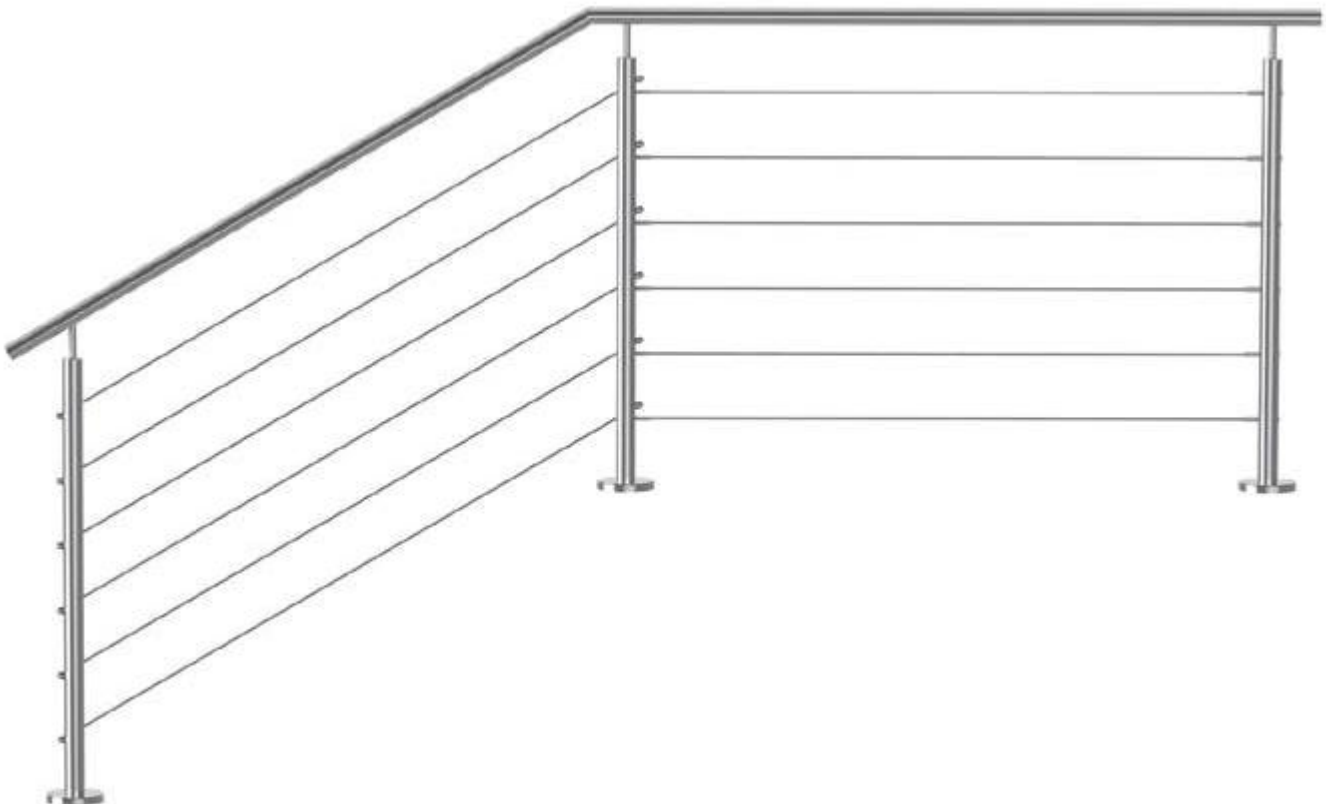



PCA-AHC-004
 Ø: 42,4x2mm
 Length: 5800mm
 Stainless Steel 304 - 316 | Material
 Satin | Finish



PCA-AHC-001
 Ø: 12mm
 Length: 5800mm
 Stainless Steel 304 - 316 | Material
 Satin | Finish



PCA-AHC-005
 □ : 40x40x2mm
 Length: 5800mm
 Stainless Steel 304 - 316 | Material
 Satin | Finish



PCA-AHC-011
 40x10 | Flat bar
 Stainless Steel 316 | Material
 Satin | Finish



PCA-AHC-007
 □ : 50x25x2mm
 Length: 5800mm
 Stainless Steel 304 - 316 | Material
 Satin | Finish



PCA-AHC-012
 15x5 | Flat bar
 Stainless Steel 316 | Material
 Satin | Finish



PCA-AHC-008
 □ : 40x10x1,3mm
 Length: 5800mm
 Stainless Steel 304 - 316 | Material
 Satin | Finish



PCA-AHC-006
 Ø: 6mm - 12mm
 Roll: 100m
 Stainless Steel 304 | Material
 Satin | Finish



PCA-AHD-001
 Stainless Steel 316 | Material
 Satin | Finish

PCA-AHB-008

Ø: 42,4mm
Stainless Steel 304 - 316 | Material
Satin | Finish

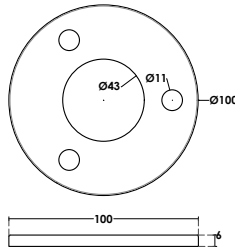

PCA-AHB-052

Ø: 42,4mm
Stainless Steel 304 - 316 | Material
Satin | Finish

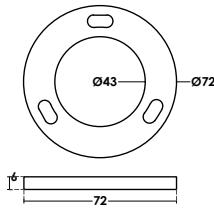

PCA-AHB-020

Ø: 42,4mm
Stainless Steel 304 - 316 | Material
Satin | Finish

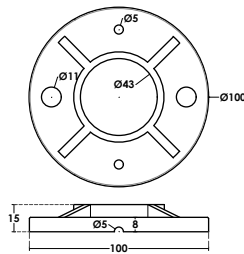

PCA-AHB-009

Ø: 42,4mm
Stainless Steel 304 - 316 | Material
Satin | Finish

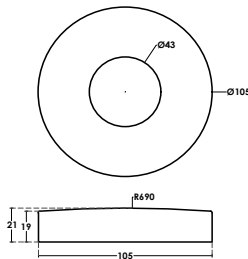

PCA-AHB-053

Ø: 42,4mm
Stainless Steel 304 - 316 | Material
Satin | Finish

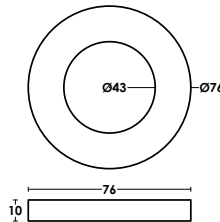

PCA-AHB-030

Ø: 42,4mm
Stainless Steel 304 - 316 | Material
Satin | Finish

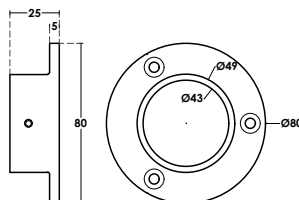

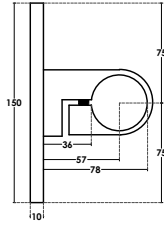
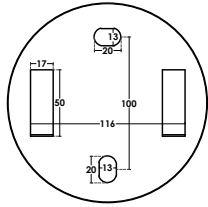

PCA-AHB-029
 Ø: 42,4mm
 Stainless Steel 304 - 316 | Material
 Satin | Finish

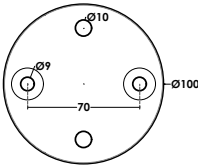
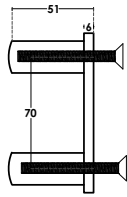

PCA-AHB-028
 Ø: 42,4mm
 Stainless Steel 304 - 316 | Material
 Satin | Finish

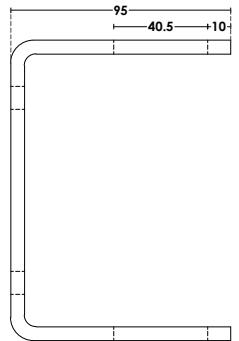
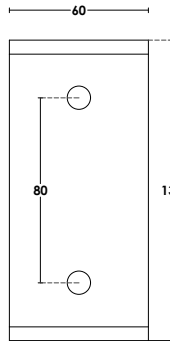
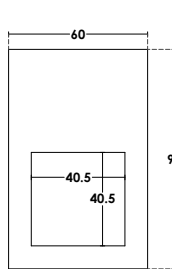

PCA-AHB-048
 □: 40x40mm
 Stainless Steel 304 - 316 | Material
 Satin | Finish

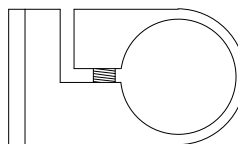
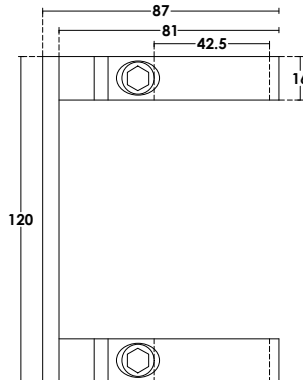
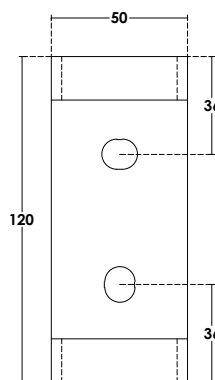

PCA-AHB-057
 Ø: 42,4mm
 Stainless Steel 304 - 316 | Material
 Satin | Finish

PCA-AHB-027

□ : 40x40mm
 Stainless Steel 304 - 316 | Material
 Satin | Finish

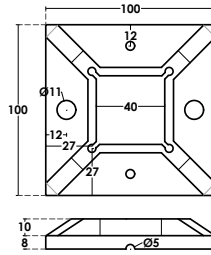

PCA-AHB-050

□ : 40x40mm
 Stainless Steel 304 - 316 | Material
 Satin | Finish

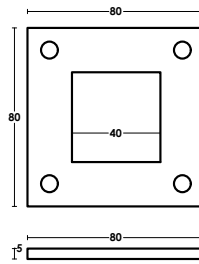

PCA-AHB-046

□ : 40x40mm
 Stainless Steel 304 - 316 | Material
 Satin | Finish

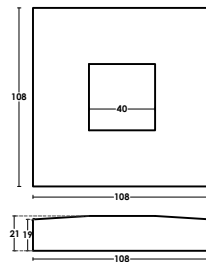

PCA-AHB-051

□ : 40x40mm
 Stainless Steel 304 - 316 | Material
 Satin | Finish

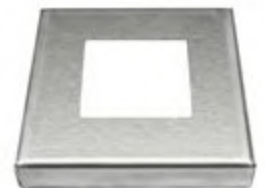
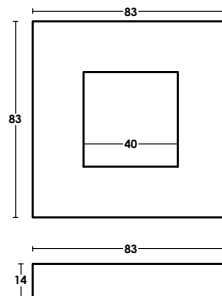

PCA-AHB-034

□ : 40x40mm
 Stainless Steel 304 - 316 | Material
 Satin | Finish

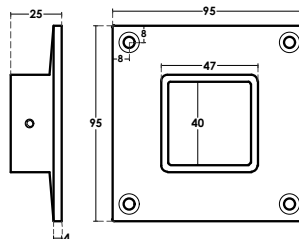

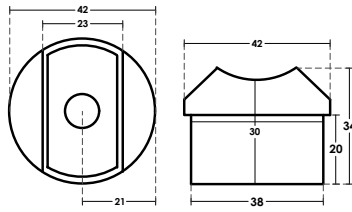

PCA-AHB-016
 Ø: 42,4mm
 Stainless Steel 304 - 316 | Material
 Satin | Finish

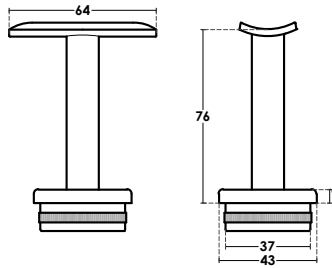

PCA-AHB-015
 Ø: 42,4mm
 Stainless Steel 304 - 316 | Material
 Satin | Finish

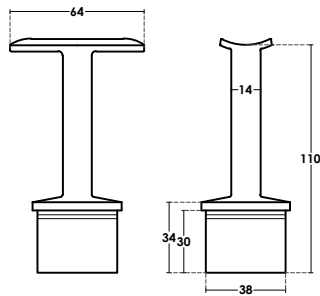

PCA-AHB-017
 Ø: 42,4mm
 Stainless Steel 304 - 316 | Material
 Satin | Finish

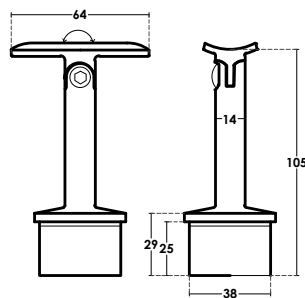

PCA-AHB-018
 Ø: 42,4mm
 Stainless Steel 304 - 316 | Material
 Satin | Finish



PCA-AHB-014

□ : 40x40mm
Stainless Steel 304 - 316 | Material
Satin | Finish

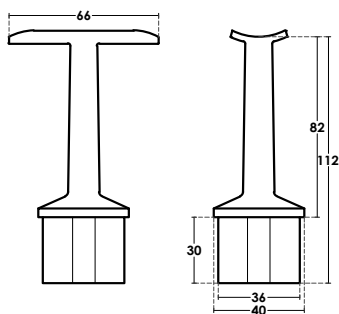

PCA-AHB-019

□ : 40x40mm
Stainless Steel 304 - 316 | Material
Satin | Finish

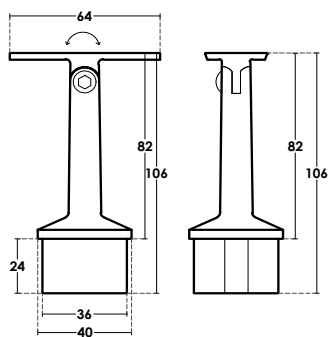

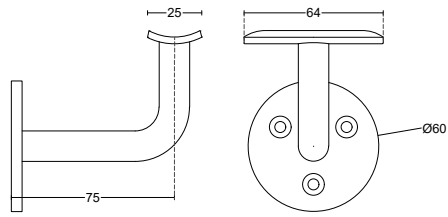
**PCA-AHB-012**

Ø: 42,4mm

Stainless Steel 304 - 316 | Material

Satin | Finish

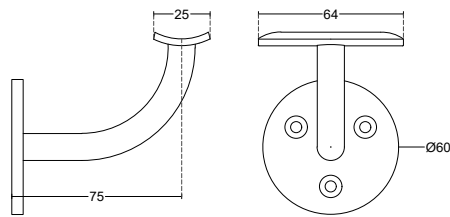
**PCA-AHB-013**

Ø: 42,4mm

Stainless Steel 304 - 316 | Material

Satin | Finish



Glass Cut

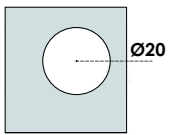

PCA-AHB-044A

Ø: 42,4mm
 10-21,52mm | Glass Thickness
 Stainless Steel 304 - 316 | Material
 Satin | Finish

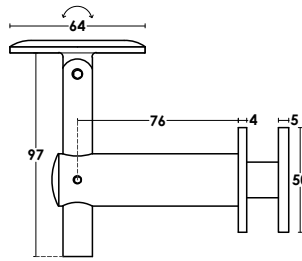

Glass Cut

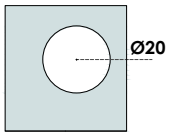

PCA-AHB-044B

□ : 40x40mm
 10-21,52 mm | Glass Thickness
 Stainless Steel 304 - 316 | Material
 Satin | Finish

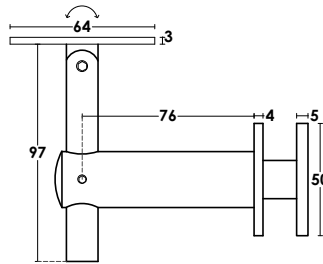

PCA-AHB-045

Ø: 42,4mm
 Stainless Steel 304 - 316 | Material
 Satin | Finish



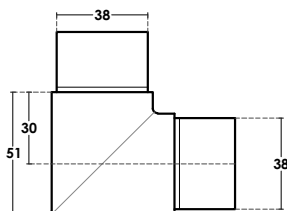

PCA-AHB-036
 Ø: 42,4mm
 Stainless Steel 304 - 316 | Material
 Satin | Finish

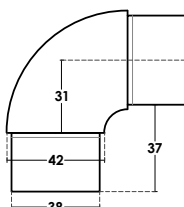

PCA-AHB-035
 Ø: 42,4mm
 Stainless Steel 304 - 316 | Material
 Satin | Finish

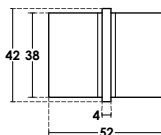

PCA-AHB-023
 Ø: 42,4mm
 Stainless Steel 304 - 316 | Material
 Satin | Finish

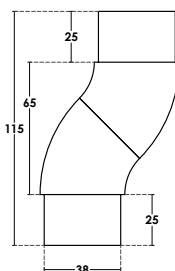

PCA-AHB-024
 Ø: 42,4mm
 Stainless Steel 304 - 316 | Material
 Satin | Finish

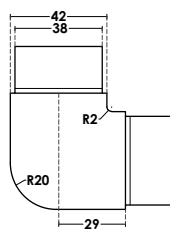

PCA-AHB-025
 Ø: 42,4mm
 Stainless Steel 304 - 316 | Material
 Satin | Finish

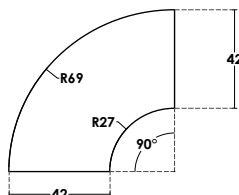

PCA-AHB-037
 Ø: 42,4mm
 Stainless Steel 304 - 316 | Material
 Satin | Finish

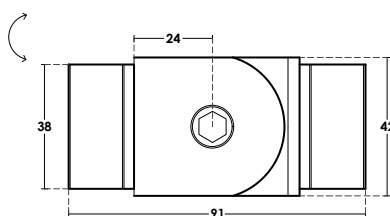

PCA-AHB-026
 Ø: 42,4mm
 Stainless Steel 304 - 316 | Material
 Satin | Finish

PCA-AHB-054

□ : 40x40mm
 Stainless Steel 304 - 316 | Material
 Satin | Finish

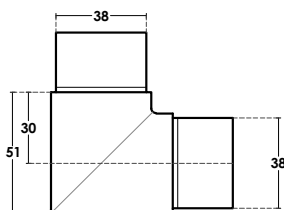

PCA-AHB-055

□ : 40x40mm
 Stainless Steel 304 - 316 | Material
 Satin | Finish

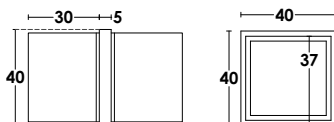

PCA-AHB-056

□ : 40x40mm
 Stainless Steel 304 - 316 | Material
 Satin | Finish

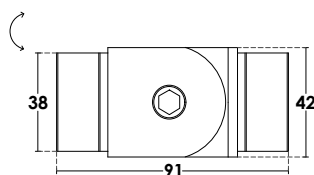

PCA-AHB-058

□ : 50x25mm
 Stainless Steel 304 - 316 | Material
 Satin | Finish

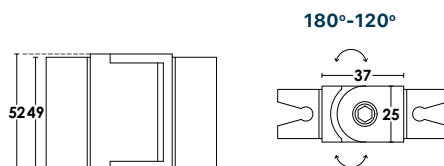

PCA-AHB-059

□ : 50x25mm
 Stainless Steel 304 - 316 | Material
 Satin | Finish

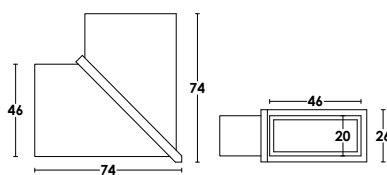

PCA-AHB-060

□ : 50x25mm
 Stainless Steel 304 - 316 | Material
 Satin | Finish

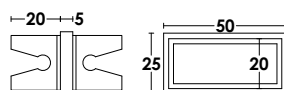

PCA-AHB-061

□ : 50x25mm
 Stainless Steel 304 - 316 | Material
 Satin | Finish

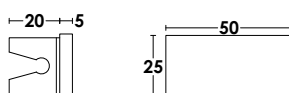

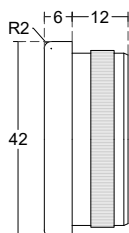

PCA-AHB-001
 Ø: 42,4mm
 Stainless Steel 304 - 316 | Material
 Satin | Finish

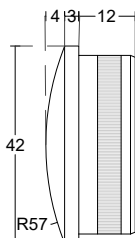

PCA-AHB-002
 Ø: 42,4mm
 Stainless Steel 304 - 316 | Material
 Satin | Finish

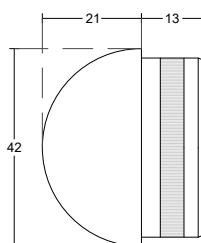

PCA-AHB-003
 Ø: 42,4mm
 Stainless Steel 304 - 316 | Material
 Satin | Finish

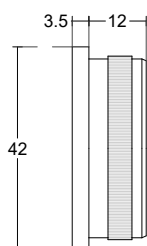

PCA-AHB-006
 Ø: 42,4mm
 Stainless Steel 304 - 316 | Material
 Satin | Finish

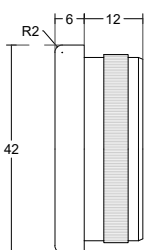

PCA-AHB-007
 Ø: 42,4mm
 Stainless Steel 304 - 316 | Material
 Satin | Finish

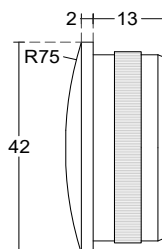

PCA-AHB-010
 Ø: 42,4mm
 Stainless Steel 304 - 316 | Material
 Satin | Finish

PCA-AHB-011

□: 40x40mm
 Stainless Steel 304 - 316 | Material
 Satin | Finish

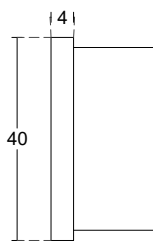

PCA-AHB-041

□: 40x40mm
 Stainless Steel 304 - 316 | Material
 Satin | Finish

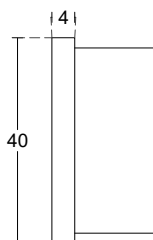

PCA-AHB-039

Ø: 12mm
 Stainless Steel 304 - 316 | Material
 Satin | Finish

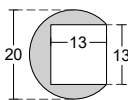

PCA-AHB-047

Ø: 12mm
 Stainless Steel 304 - 316 | Material
 Satin | Finish

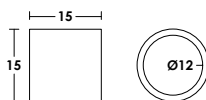

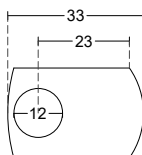
**PCA-AHB-040**

Ø: 42,4mm
Stainless Steel 304 - 316 | Material
Satin | Finish

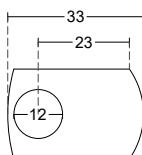
**PCA-AHB-049**

Ø: 42,4mm
Stainless Steel 304 - 316 | Material
Satin | Finish

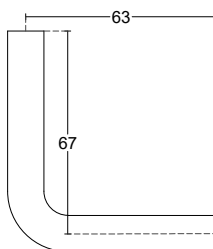
**PCA-AHB-005**

Ø: 12mm
Stainless Steel 304 - 316 | Material
Satin | Finish

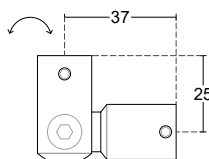
**PCA-AHB-031**

Ø: 12mm
Stainless Steel 304 - 316 | Material
Satin | Finish

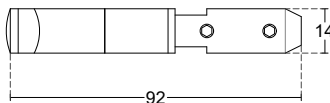
**PCA-AHB-033A**

Ø: 6mm
Stainless Steel 304 - 316 | Material
Satin | Finish

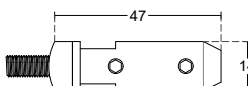
**PCA-AHB-033B**

Ø: 6mm
Stainless Steel 304 - 316 | Material
Satin | Finish

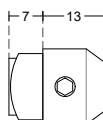
**PCA-AHB-033C**

Ø: 6mm
Stainless Steel 304 - 316 | Material
Satin | Finish

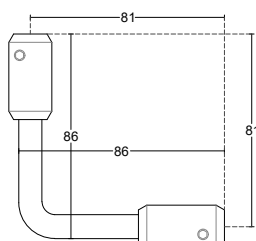
**PCA-AHB-032**

Ø: 6mm
Stainless Steel 304 - 316 | Material
Satin | Finish

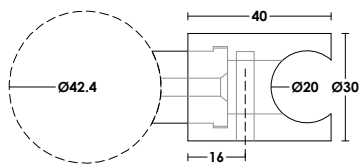

PCA-AHB-062
 Ø: 20mm | Rod
 Stainless Steel 304 - 316 | Material
 Satin | Finish

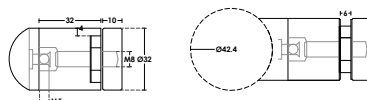

PCA-AHB-063
 Ø: 12mm |
 Stainless Steel 304 - 316 | Material
 Satin | Finish

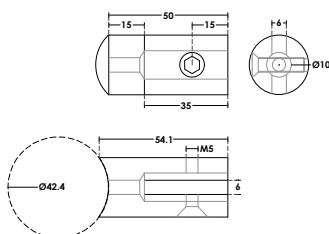

PCA-AHB-064
 6mm | Panel
 Stainless Steel 304 - 316 | Material
 Satin | Finish

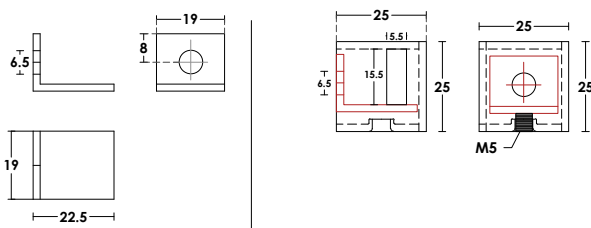

PCA-AHB-065
 15x5 | Flat bar
 Stainless Steel 304 - 316 | Material
 Satin | Finish

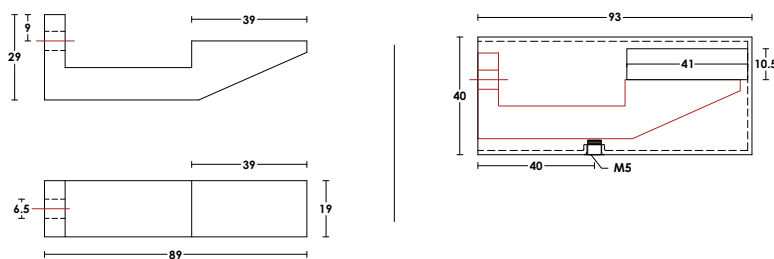

PCA-AHB-066
 40x10 | Flat bar
 Stainless Steel 304 - 316 | Material
 Satin | Finish

PCA-AHC-002

Ø: 6mm
 Stainless Steel 304 - 316 | Material
 Satin | Finish 

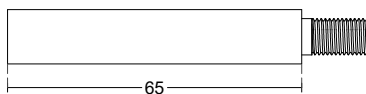

PCA-AHC-003

Ø: 6mm
 Stainless Steel 304 - 316 | Material
 Satin | Finish 

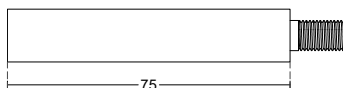

PCA-AHB-021

Ø: 42,4mm
 Stainless Steel 304 - 316 | Material
 Satin | Finish 

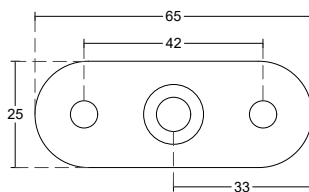

PCA-AHB-022

□: Square tube
 Stainless Steel 304 - 316 | Material
 Satin | Finish 

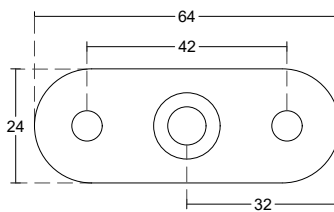

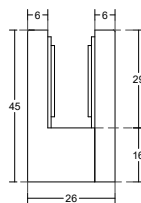
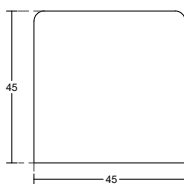

PCA-GC21
 □ : Square tube
 10mm | Glass Thickness
 Stainless Steel 304 - 316 | Material
 Satin | Finish

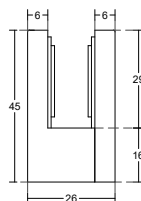
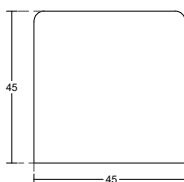

PCA-GC21A
 □ : Square tube
 10mm | Glass Thickness
 Stainless Steel 304 - 316 | Material
 Satin | Finish

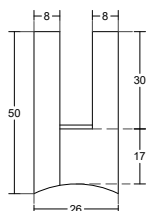
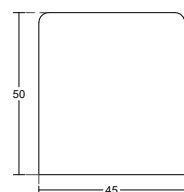

PCA-GC20
 Ø: 42,4mm
 10mm | Glass Thickness
 Stainless Steel 304 - 316 | Material
 Satin | Finish

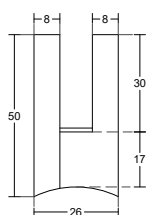
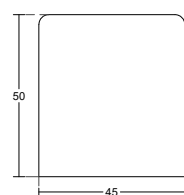

PCA-GC20A
 Ø: 42,4mm
 10mm | Glass Thickness
 Stainless Steel 304 - 316 | Material
 Satin | Finish

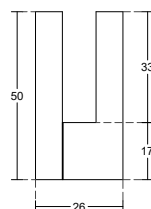
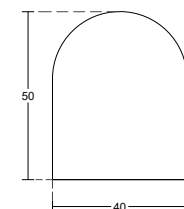

PCA-GC30
 □ : Square tube
 10mm | Glass Thickness
 Stainless Steel 304 - 316 | Material
 Satin | Finish

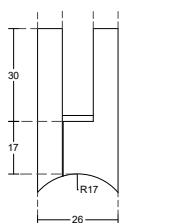
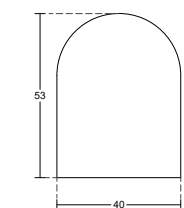

PCA-GC29
 Ø: 42,4mm
 10mm | Glass Thickness
 Stainless Steel 304 - 316 | Material
 Satin | Finish

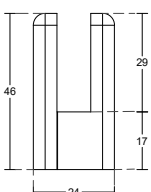
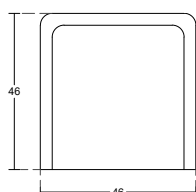

PCA-GC24
 □ : Square tube
 8mm | Glass Thickness
 Zinc Alloy | Material
 Satin | Finish

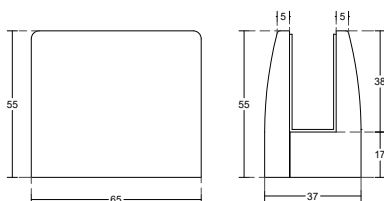

PCA-GC25
 □ : Square tube
16mm | Glass Thickness
 Stainless Steel 304 | Material
 Satin | Finish

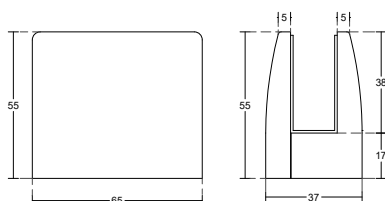

PCA-GC25A
 □ : Square tube
16mm | Glass Thickness
 Stainless Steel 304 | Material
 Satin | Finish

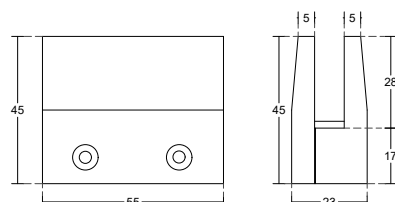

PCA-GC27
 □ : Square tube
10mm | Glass Thickness
 Aluminium | Material
 Natural Anodize | Finish

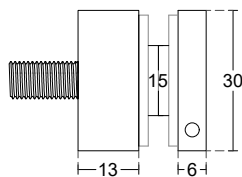

PCA-AHB-004
8mm | Glass Thickness
 Stainless Steel 304 - 316 | Material
 Satin | Finish

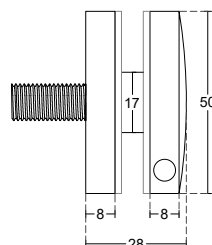

PCA-AHB-042
8mm | Glass Thickness
 Stainless Steel 304 - 316 | Material
 Satin | Finish



PCA-AHB-068
 Ø: 12mm
 Stainless Steel 304 - 316 | Material
 Satin | Finish



PCA-AHB-067
 Ø: 12mm
 Stainless Steel 304 - 316 | Material
 Satin | Finish

Shower Cabins & WC Partitions	8
Doors & Office Partitions	81
Facades	169
Folding	199
Guillotine	209
Spiders	215
Balcony Railings	225
Inox Railings	273
Staircase	293
Canopies	297
Miscellaneous & Consumables	307

L1 | STAIRCASE SERIES

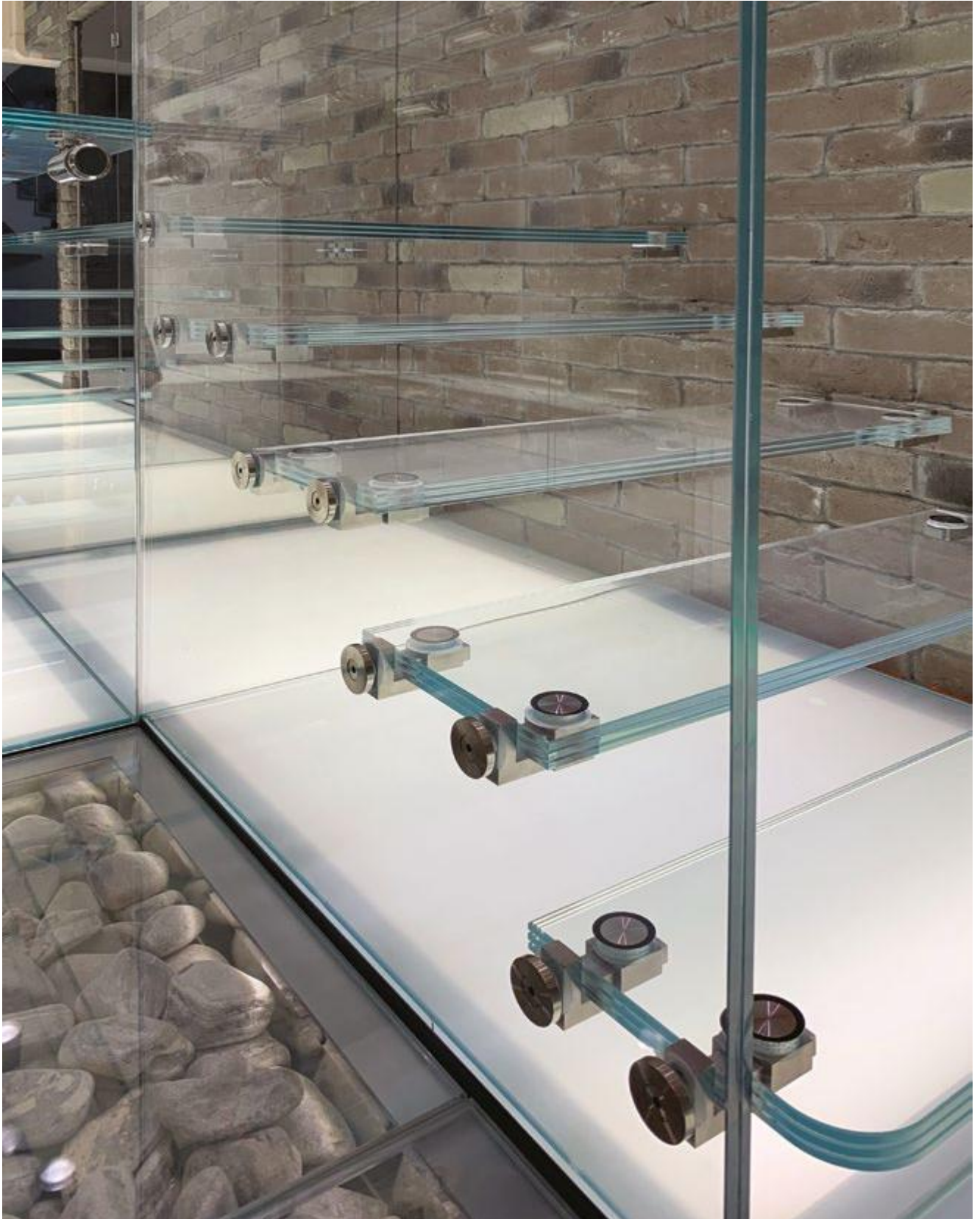

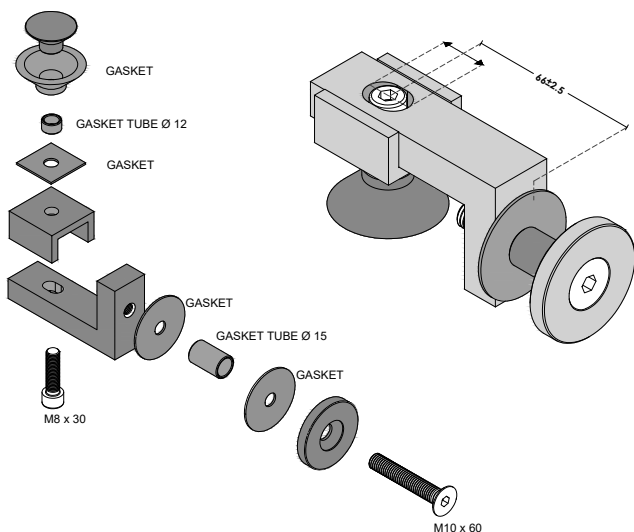

PCA-FC11
Glass Staircase Fitting
 560 gr | Weight
 50kg | Max Weight
 16-30mm | Glass Thickness
 Stainless Steel 304 | Material
 Satin | Finish

Glass - Glass

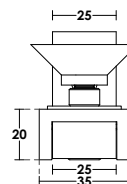
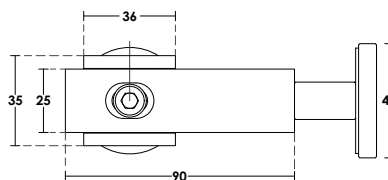
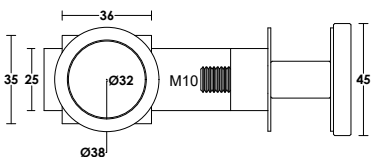
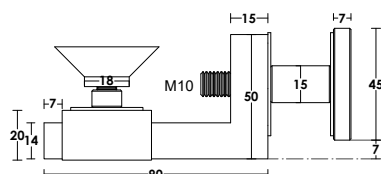

Wall - Glass

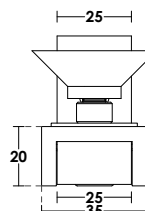
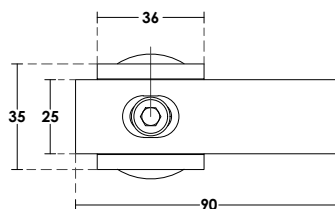
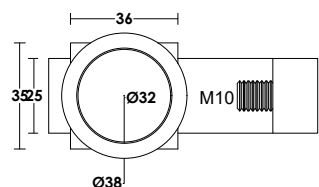
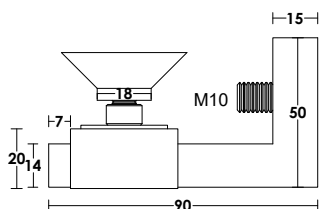

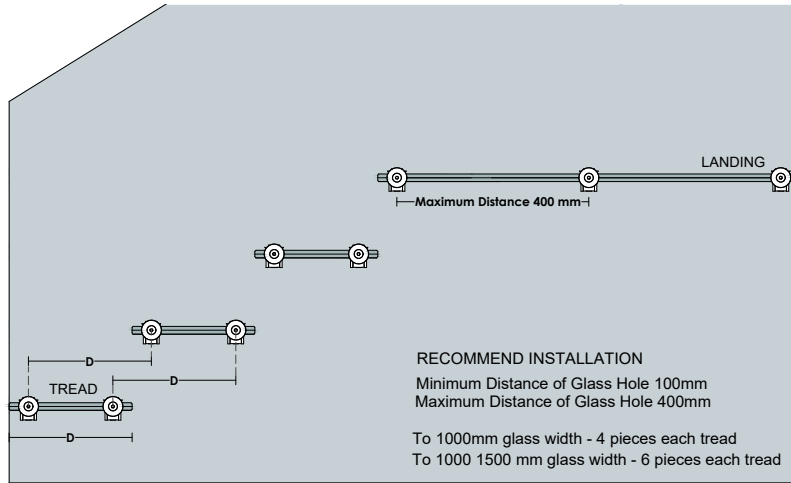

Glass Preparation

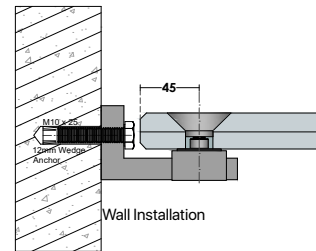
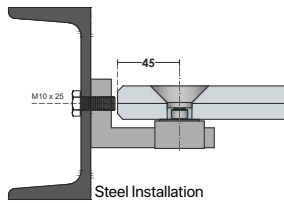
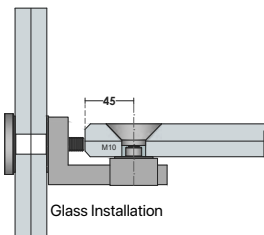

L 1100

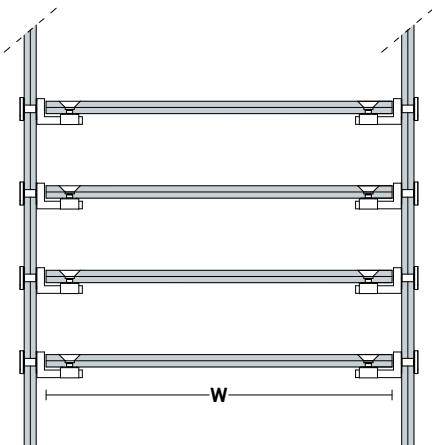

L 1200

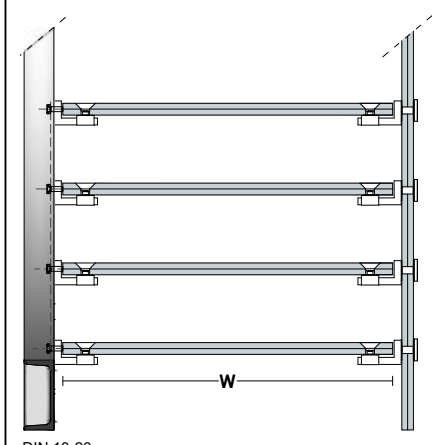

L 1300

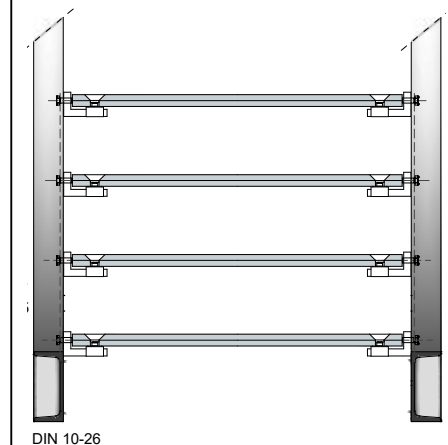

Shower Cabins & WC Partitions	8
Doors & Office Partitions	81
Facades	169
Folding	199
Guillotine	209
Spiders	215
Balcony Railings	225
Inox Railings	273
Staircase	293
Canopies	297
Miscellaneous & Consumables	307

E1 | CANOPIES SERIES



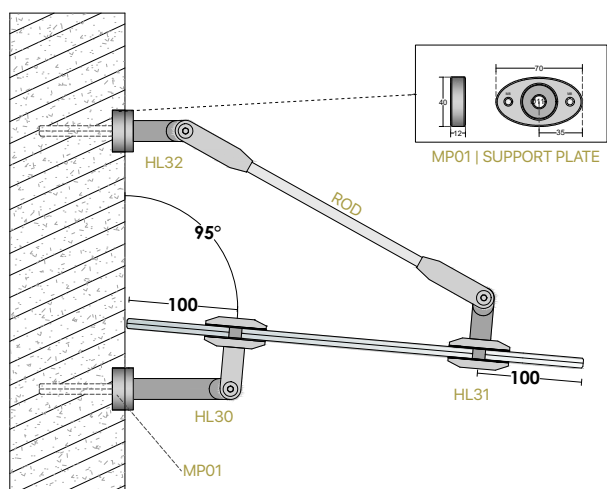

TYPOLOGIES

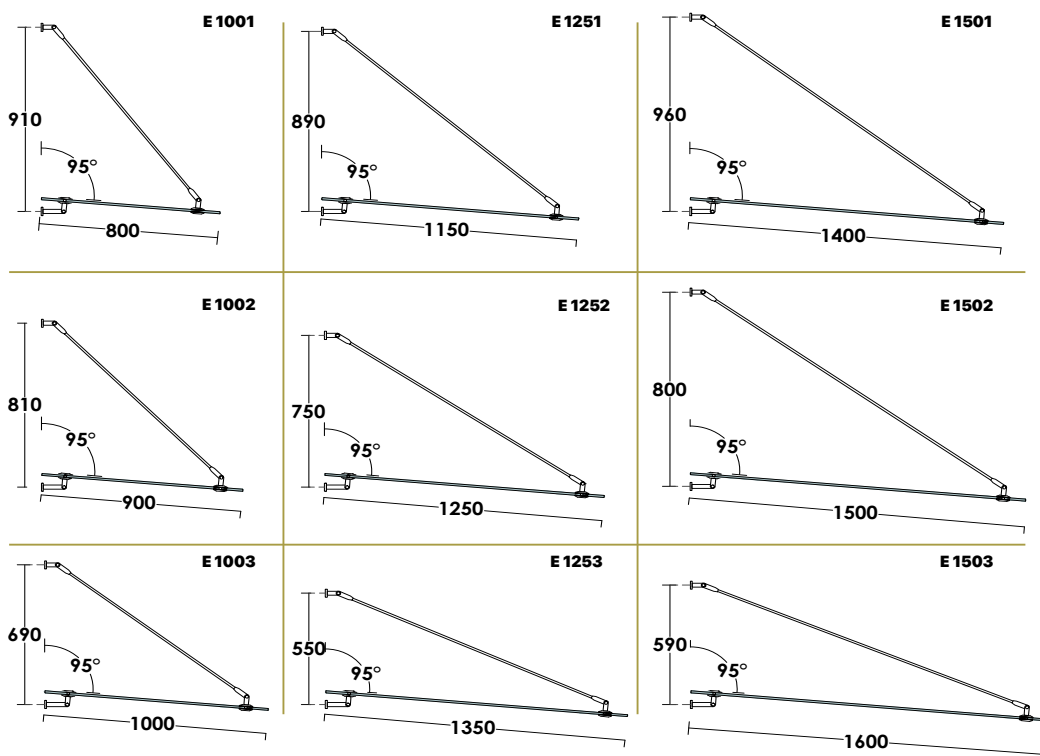

System	Rod size	Glass Width [W]	Height [H]
E 1001	1000mm	800mm	910mm
E 1002	1000mm	900mm	810mm
E 1003	1000mm	1000mm	690mm
E 1251	1250mm	1150mm	890mm
E 1252	1250mm	1250mm	750mm
E 1253	1250mm	1350mm	550mm
E 1501	1500mm	1400mm	960mm
E 1502	1500mm	1500mm	800mm
E 1503	1500mm	1600mm	590mm

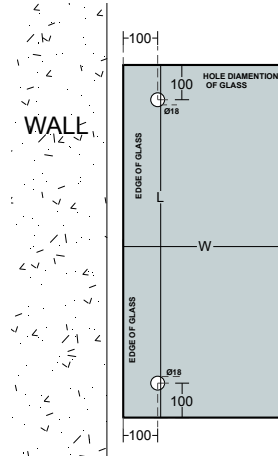
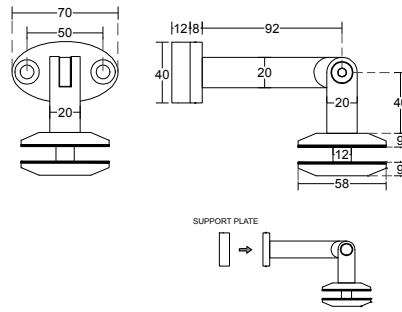

PCA-HL30
Wall - Glass Fitting
 10,76-21,52 | Glass Thickness
 80 kg | Weight
 Stainless Steel 304 | Material
 Satin | Finish

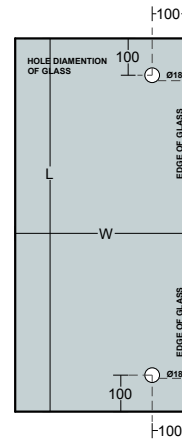
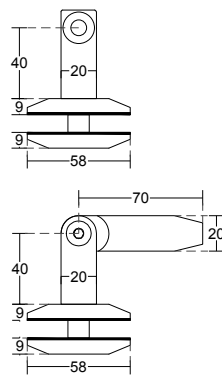

PCA-HL31
Glass - Rod Fitting
 10,76-21,52 | Glass Thickness
 80 kg | Weight
 Stainless Steel 304 | Material
 Satin | Finish

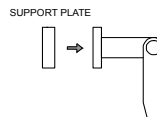
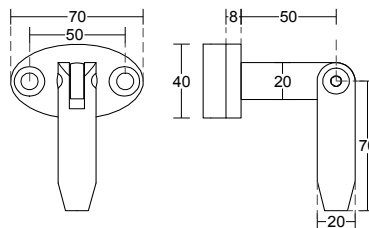

PCA-HL32
Wall - Rod Fitting
 10,76-21,52 | Glass Thickness
 80 kg | Weight
 Stainless Steel 304 | Material
 Satin | Finish

PCA-MP01
Support Plate
 80 kg | Weight
 Stainless Steel 304 | Material
 Satin | Finish

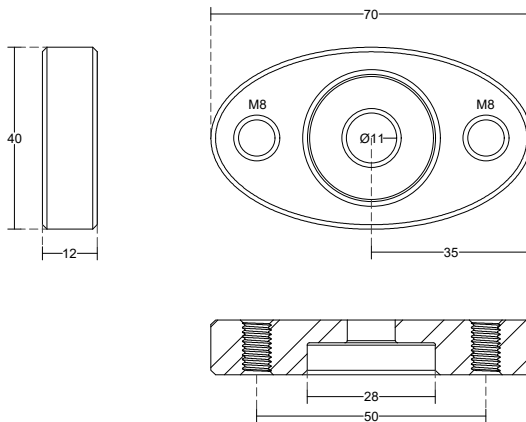

CANOPIES

PCA-RD02
Canopy Rod
 80 kg | Weight
 Stainless Steel 304 | Material
 Satin | Finish

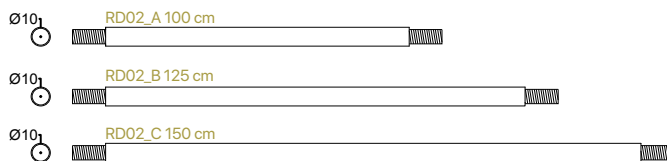

E2 | CANOPIES SERIES



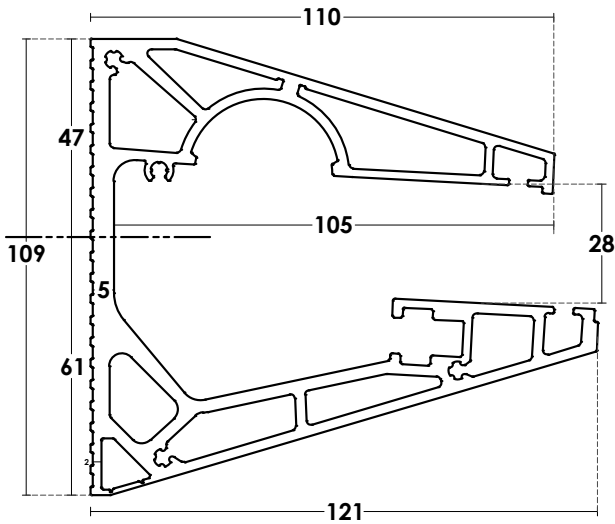

PCA-CN01-1
Canopy Profile
 80 kg | Weight
 21,52 mm | Glass Thickness
 350cm | Length
 Aluminium | Material
 Natural Anodize, Satin | Finish

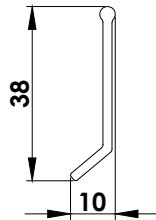

PCA-CN01-2
 350cm | Length
 Aluminium | Material
 Mill | Finish

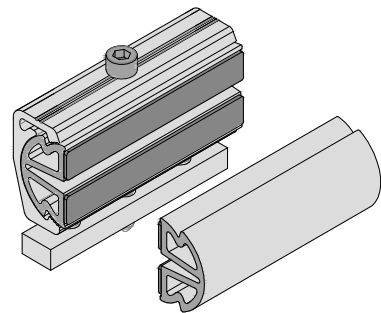
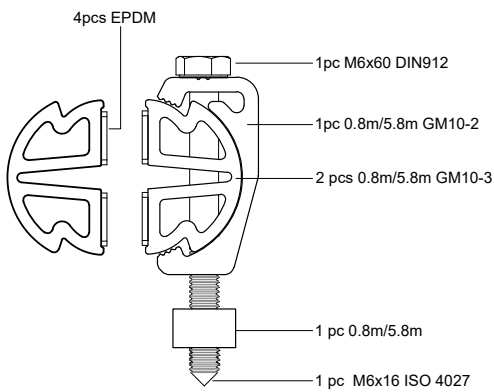

PCA-CN01-10
 10,10,4mm | Glass Thickness
 6cm | Length
 Aluminium | Material



PCA-GM10-20A
 Canopy Profile Fixing Rubber
 30m Roll | Unit



PCA-GM10-20B
 Canopy Profile Fixing Rubber
 30m Roll | Unit

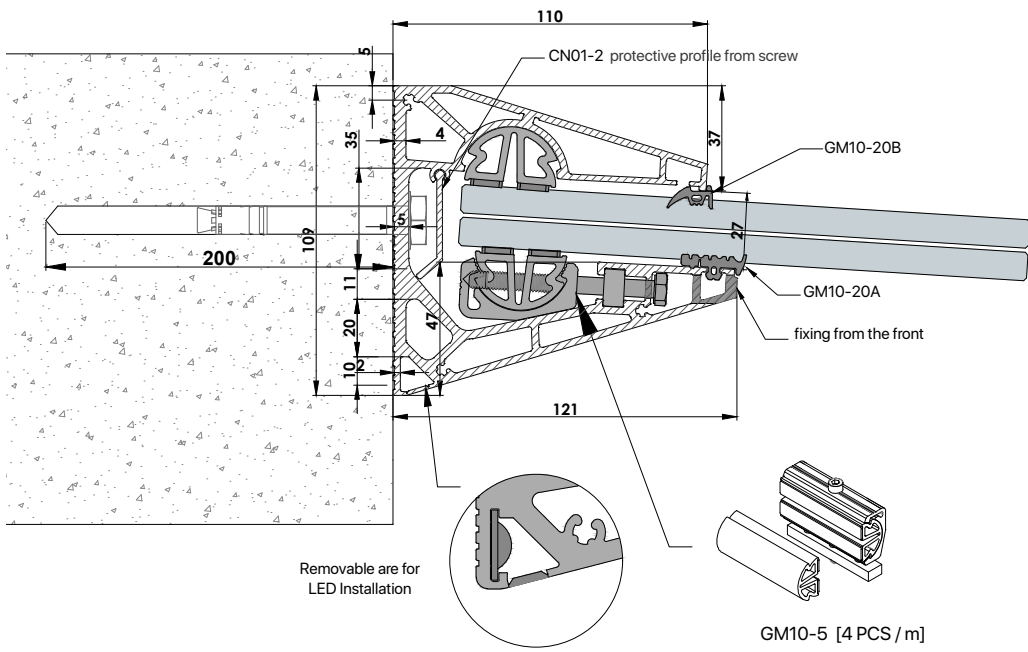

CNC Processing

CN01-1

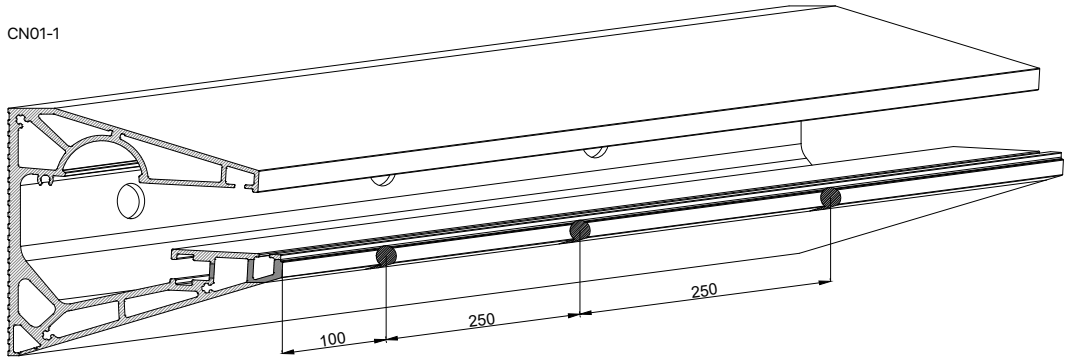

DESCRIPTION:
 -Profile length: 3,5 m
 -Maximum glass width: 110cm
 -Glass thickness 10+10+1,52 tempered and laminated
 -Up to 200kg load/m² excluded the glasse's weight.

CANOPIES SERIES | **E3**

CANOPIES



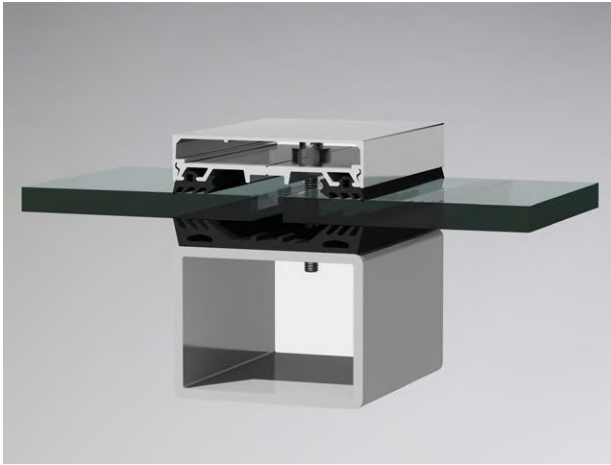

PCA-CN02
Canopy Profile
 80 kg | Weight
 12,16,20mm | Glass Thickness
 580cm | Length
 Aluminium | Material
 Natural Anodize, Satin, Mill | Finish

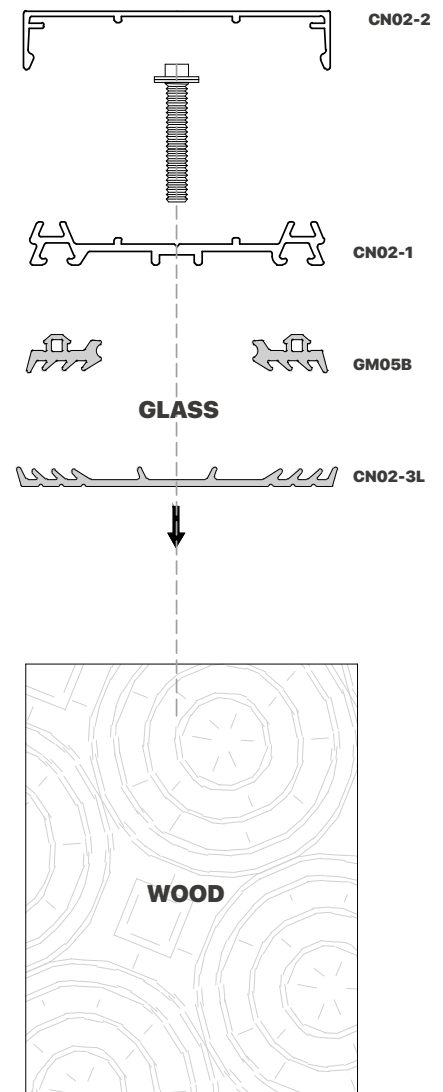
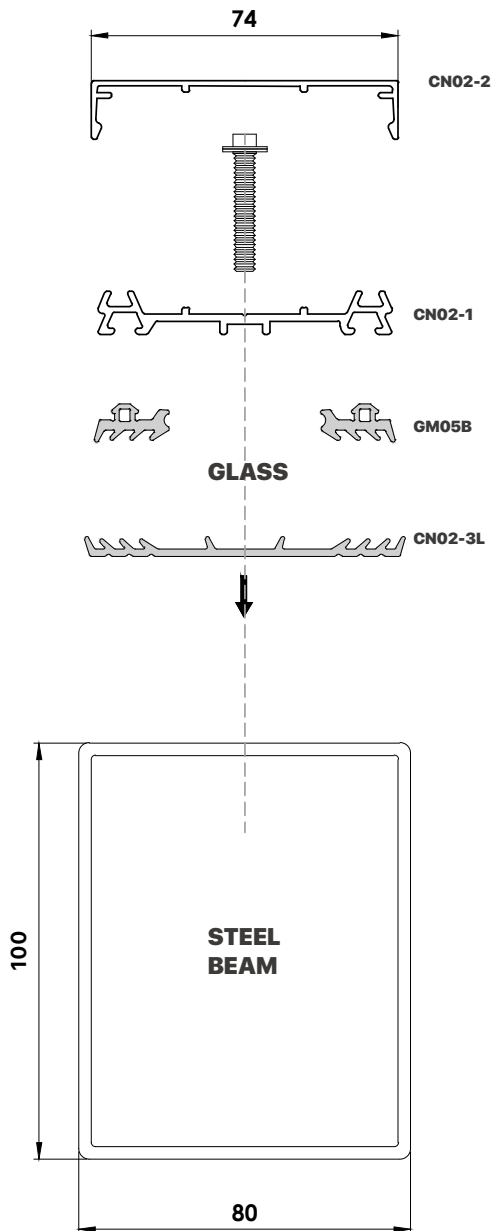

Shower Cabins & WC Partitions	8
Doors & Office Partitions	81
Facades	169
Folding	199
Guillotine	209
Spiders	215
Balcony Railings	225
Inox Railings	273
Staircase	293
Canopies	297
Miscellaneous & Consumables	307



**PCA-HR01 | HR02 | HR03
Self Holder**
5-10mm | Glass Thickness
Zinc Alloy | Material
Satin, Polished | Finish

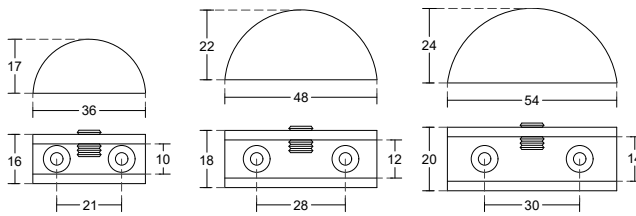

**PCA-HR04
Self Holder**
5-10mm | Glass Thickness
Zinc Alloy | Material
Satin, Polished | Finish

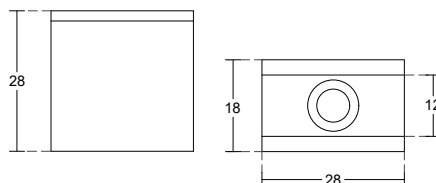

**PCA-HR05
Self Holder**
5-10mm | Glass Thickness
Zinc Alloy | Material
Satin, Polished | Finish

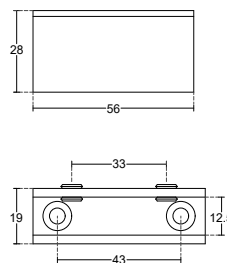

**PCA-HR06
Self Holder**
5-10mm | Glass Thickness
Zinc Alloy | Material
Satin, Polished | Finish

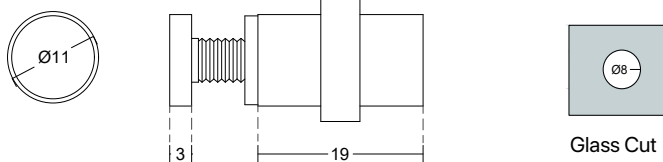

**PCA-HR07
Self Holder**
5-10mm | Glass Thickness
Zinc Alloy | Material
Satin, Polished | Finish

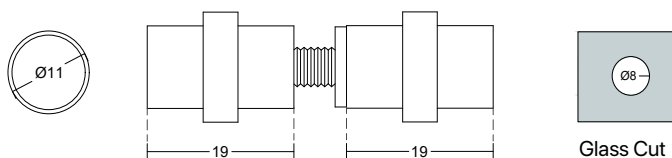

**PCA-HR08
Self Holder**
5-10mm | Glass Thickness
Zinc Alloy | Material
Satin, Polished | Finish

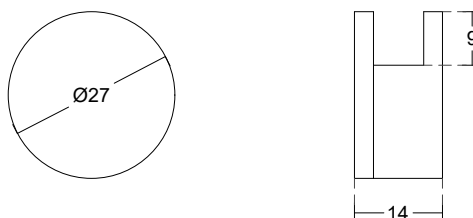

	Height H	Weight W	Depth D	Size A
HR09A	34mm	40mm	24mm	17mm
HR09B	45mm	55mm	28mm	22mm
HR09C	52mm	75mm	30mm	30mm
HR09D	58mm	103mm	31mm	45mm

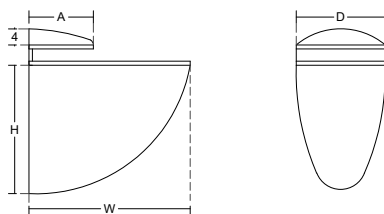

**PCA-HR09
Self Holder**
5-10mm | Glass Thickness
Zinc Alloy | Material
Satin, Polished | Finish

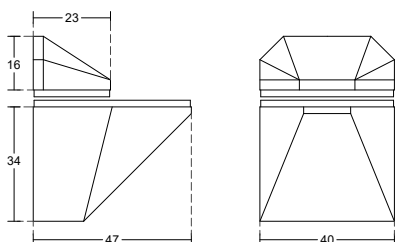

**PCA-HR10
Self Holder**
5-10mm | Glass Thickness
Zinc Alloy | Material
Satin, Polished | Finish

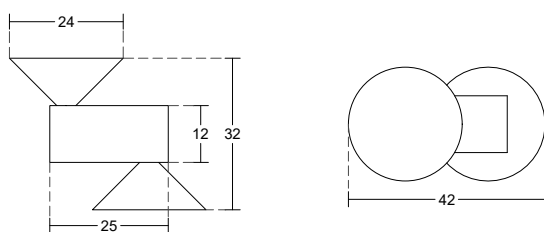

**PCA-HR12
Glass self Hinge**
5-10mm | Glass Thickness
Stainless Steel 304 | Material
Satin | Finish

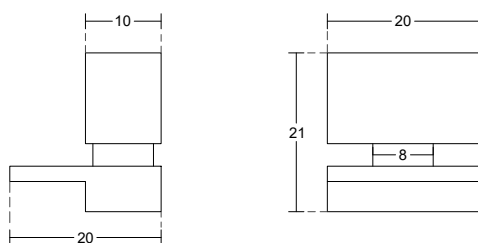

**PCA-HR13
Glass self Hinge**
5-10mm | Glass Thickness
Stainless Steel 304 | Material
Satin | Finish



	Height H	Weight W	Depth D	Size A
HR18A	65mm	65mm	24mm	26mm
HR18B	80mm	78mm	26mm	32mm

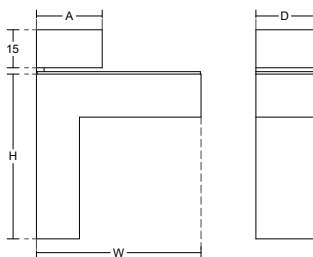

**PCA-HR18
Self Holder**
5-10mm | Glass Thickness
Zinc Alloy | Material
Satin, Polished | Finish

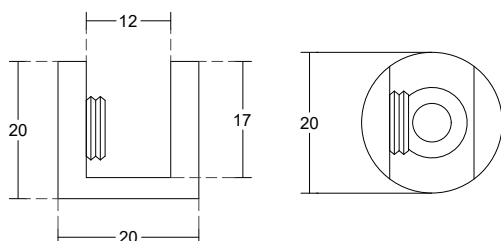

**PCA-HR20
Self Holder**
5-10mm | Glass Thickness
Zinc Alloy | Material
Satin, Polished | Finish



CONSUMABLES



GC20



GC20A

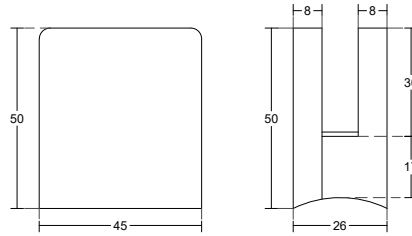

**PCA-GC20 | GC20A
Clamp**
10mm | Glass Thickness
Stainless Steel 304 - 316 | Material
Satin | Finish

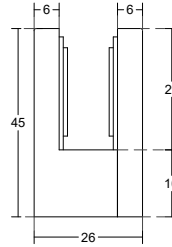
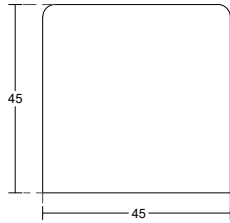

**PCA-GC21
Clamp**
10mm | Glass Thickness
Stainless Steel 304 | Material
Satin | Finish

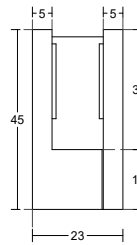
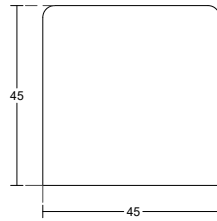

**PCA-GC21A
Clamp**
10mm | Glass Thickness
Stainless Steel 304 | Material
Satin | Finish

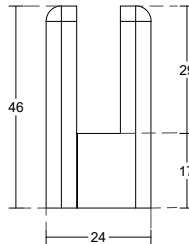
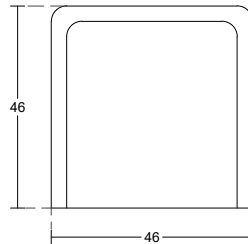

**PCA-GC24
Clamp**
8mm | Glass Thickness
Zinc Alloy | Material
Satin, Polished | Finish

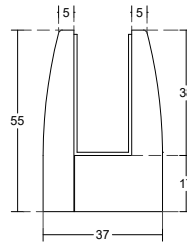
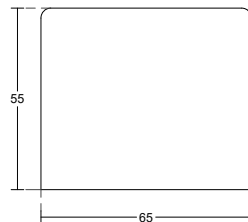

**PCA-GC25
Clamp**
16mm | Glass Thickness
Stainless Steel 304 | Material
Satin | Finish

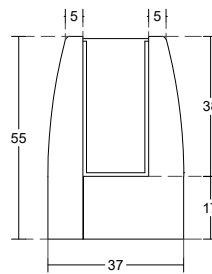
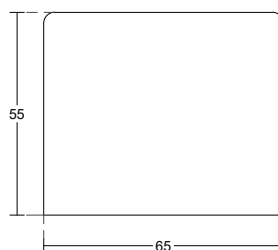

**PCA-GC25A
Clamp**
16mm | Glass Thickness
Stainless Steel 304 | Material
Satin | Finish

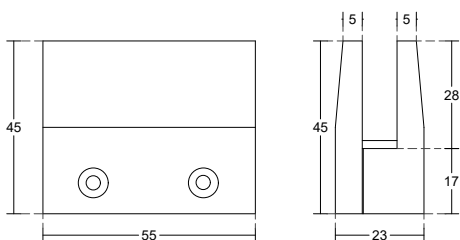

PCA-GC27
Clamp
 10mm | Glass Thickness
 Aluminium | Material
 Natural Anodize | Finish

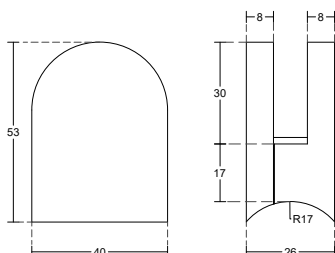

PCA-GC29
Clamp
 10mm | Glass Thickness
 Stainless Steel 304 - 316 | Material
 Satin | Finish

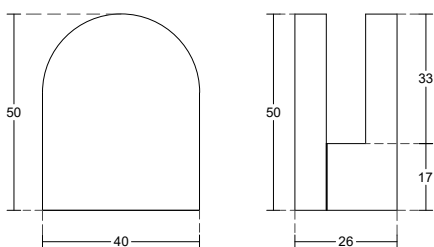

PCA-GC30
Clamp
 10mm | Glass Thickness
 Stainless Steel 304 - 316 | Material
 Satin | Finish

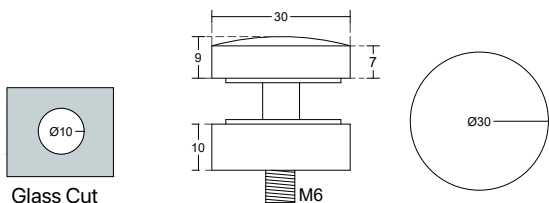

PCA-AM01
Ø30mm Anchor Spacer
 30 kg | Weight
 10mm | Glass Thickness
 Stainless Steel 304 | Material
 Satin | Finish

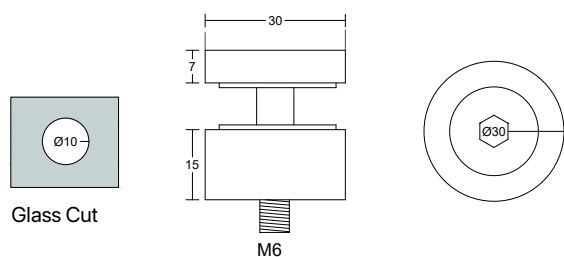



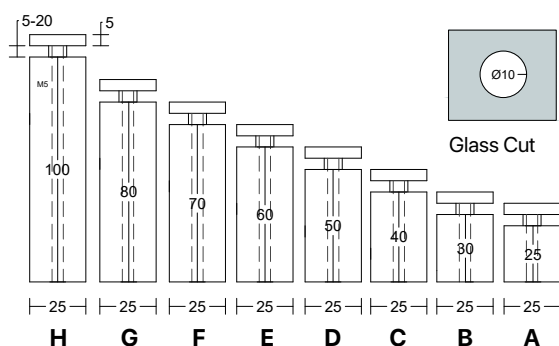

PCA-AM02
Ø30mm Anchor Spacer
 30 kg | Weight
 10mm | Glass Thickness
 Stainless Steel 304 | Material
 Satin | Finish

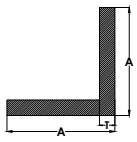

PCA-AM03
Ø25mm Anchor Spacer
 30 kg | Weight
 10mm | Glass Thickness
 Zinc Alloy | Material
 Satin, Polished | Finish

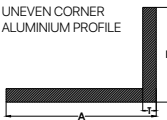
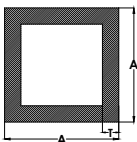

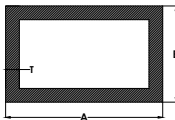
	DIMENSIONS (A x B x T)	LENGTH	WEIGHT/bar	PRODUCT CODE
<p>EVEN CORNER ALUMINIUM PROFILE</p> 	20x20x1,2	5,8m	0,78 kg	GGL20
	25x25x1,1	5,8m	0,9 kg	GGL25
	30x30x1,2	5,8m	1,18 kg	GGL30
	40x40x1,2	5,8m	1,57 kg	GGL40
	40x40x3	5,8m	3,85 kg	GGL40.3
<p>U CHANNEL PROFILE</p> 	13,8x13,8x1,3	5,8m	0,85 kg	U13.8
	15,5x20x1,5	5,8m	1,3 kg	U15.5
	20x20x1,3	5,8m	0,202 kg	GG20
	20x30x1,3	5,8m	0,272 kg	GG30
	20x40x1,3	5,8m	0,342 kg	GG40
	22x13x1,2	5,8m	0,92 kg	U22
	25x20x1,6	5,8m	1,66 kg	U25
	27,8x22,2x1,2	5,8m	1,37 kg	U27
	28x18x0,9	5,8m		U28
39x20x2	3m	1,12 kg	GGV2	
<p>UNEVEN CORNER ALUMINIUM PROFILE</p> 	18x8,5x1,1	5,8m	0,47 kg	UA-18
	30x18x1,3	5,8m	1,01 kg	UA-30
	40x20x1,3	5,8m	1,3 kg	UA-40
<p>SQUARE HOLLOW ALUMINIUM PROFILE</p> 	20x20x0,9	5,8m	1,15 kg	SHT-20
	30x30x1,1	5,8m	1,84 kg	SHT-30
	40x40x1,2	5,8m	3,08 kg	SHT-40
	50x50x1,2	5,8m	3,16 kg	SHT-50
	60x60x1,35	5,8m	5,28 kg	SHT-60
<p>FLAT ALUMINIUM PROFILE</p> 	10x3	5,8m	0,45 kg	FB-10
	20x3	5,8m	0,92 kg	FB-20
	25x2	3m	0,1 kg	GGV4
	25x3	5,8m	1,16 kg	FB-25
	30x3	5,8m		FB-30
	40x4	5,8m	2,5 kg	FB-40
	45x2	3m	0,18 kg	GGV3
<p>RECTANGULAR HOLLOW ALUMINIUM PROFILE</p> 	30x20x1,2	5,8m	1,93 kg	RHT-30
	40x20x1	5,8m	1,94 kg	RHT-40
	50x20x1,2	5,8m	2,69 kg	RHT-50x20
	50x30x1,8	5,8m	4,67 kg	RHT-50x30
	60x20x1,5	5,8m	3,81 kg	RHT-60
	80x18x8	5,8m	3,13 kg	RHT-80x18
	80x25x1,2	5,8m	3,4 kg	RHT-80x25
	100x20x1,1	5,8m	4,69 kg	RHT-100

AVAILABLE FINISHES: SATIN, NATURAL ANODIZE, BLACK ANODIZE



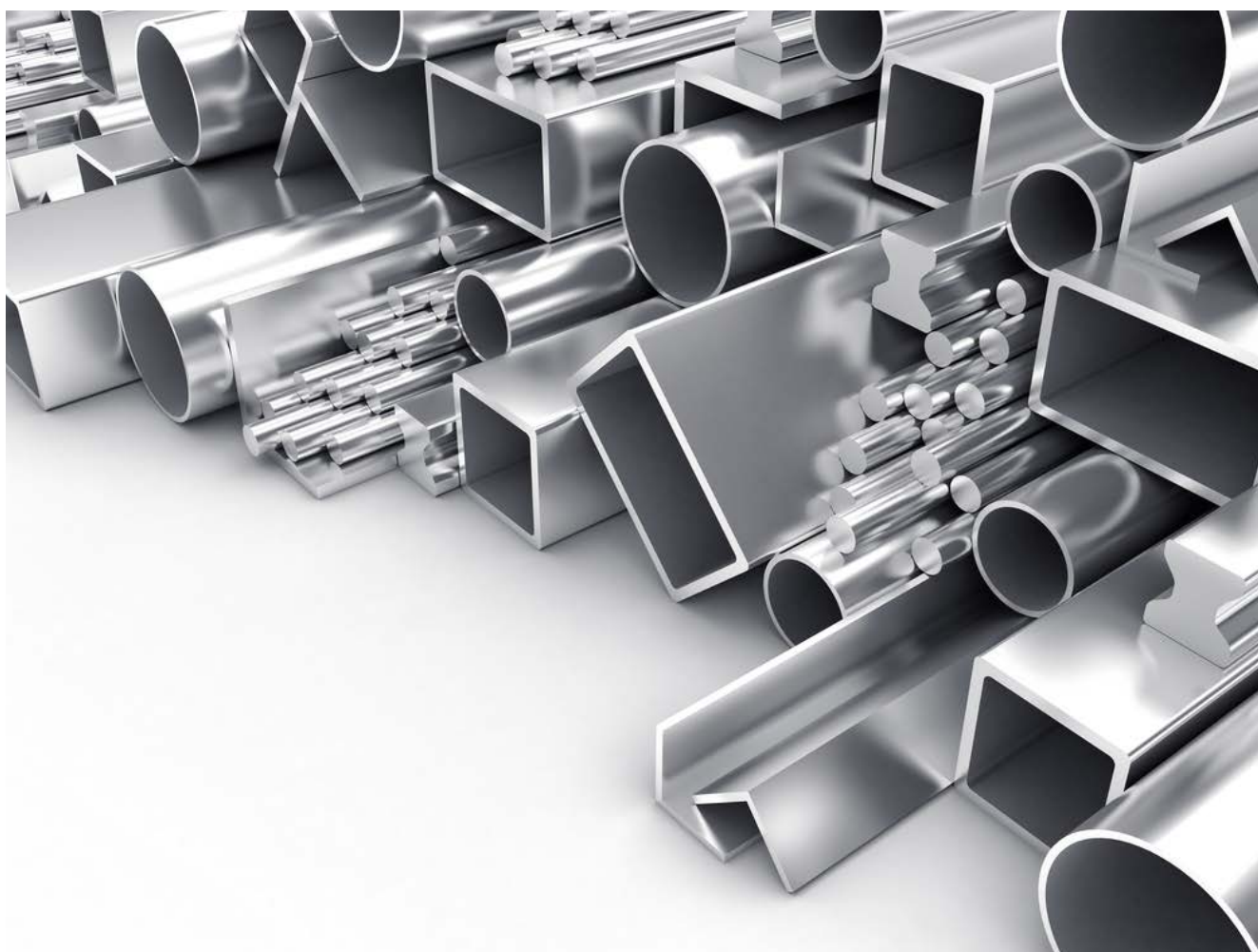

Fittings and Profiles Index

AH

AHB-001	286
AHB-002	286
AHB-003	286
AHB-004	292
AHB-005	288
AHB-006	286
AHB-007	286
AHB-008	277
AHB-009	277
AHB-010	286
AHB-011	287
AHB-012	282
AHB-013	282
AHB-014	281
AHB-015	280
AHB-016	280
AHB-017	280
AHB-018	280
AHB-019	281
AHB-020	277
AHB-021	289
AHB-022	289
AHB-023	284
AHB-024	284
AHB-025	284
AHB-026	284
AHB-027	279
AHB-028	278
AHB-029	278
AHB-030	277
AHB-031	288
AHB-032	288
AHB-033A	288
AHB-033B	288
AHB-033C	288
AHB-034	279
AHB-035	284
AHB-036	284
AHB-037	284
AHB-039	287
AHB-040	288
AHB-041	287
AHB-042	292
AHB-044A	283
AHB-044B	283
AHB-045	283
AHB-046	279
AHB-047	287
AHB-048	278
AHB-049	288
AHB-050	279
AHB-051	279
AHB-052	277
AHB-053	277
AHB-054	285
AHB-055	285
AHB-056	285
AHB-057	278
AHB-058	285
AHB-059	285
AHB-060	285
AHB-061	285
AHB-062	289
AHB-063	289
AHB-064	289
AHB-065	289
AHB-066	289
AHC-001	276
AHC-002	289
AHC-003	289
AHC-004	276
AHC-005	276
AHC-006	276
AHC-007	276
AHC-011	276
AHC-012	276
AHD-001	276

AM

AM01	311
AM02	311
AM03	311

AN

AN01	266
AN02	266
AN03	266
AN04	266
AN05	266
AN06	266
AN07	266
AN08	266
AN11	271
AN12	265
AN13	265
AN14	267
AN15	267

BL

BL08	195
BL08S	195
BL09	205
BL10	205
BL12	186
BL13	186
BL15	72
BL16	72

BM

BM07	269
BM12	260
BM13	261
BM14	262

BR

BR01	80
BR02	80
BR03	80
BR04	80

CN

CN01	303
CN01-10	303
CN02	306

DC

DC01	182
DC02	182
DC03	182

DH

DH12	161
DH13	161
DH15	160
DH-2D	161
DH-3D	160

DK

DK03	74
DK04	75
DK06	74
DK08	74
DK08S	74
DK11	77
DK13A	76
DK13B	76
DK14	76
DK15	77
DK16	76
DK18	75
DK19	75
DK20	73
DK21	73
DK22	73
DK24	77

DL

DL04	163
DL04B	163
DL07A	163
DL09	110
DL09A	163
DL09B	110
DL21	186
DL23	186
DL24	205
DL25	186
DL27	186

FC

FC01	189
FC02	189
FC03	189
FC04	189
FC06	188
FC07	188
FC08	188
FC09	191
FC10	191
FC11	295

FD

FD01	206
------	-----

FG

FG01	47
FG02	47
FG03	47
FG04	47
FG05	44
FG06	44
FG07	44
FG08	108
FG09	47
FG10	44

FH

FH01	184
FH02	184
FH03	184
FH04	184
FH04A	184
FH10L	190
FH10R	190
FH11	190
FH12A	190
FH12B	190
FH13	190
FH15	191
FH18	206
FH19	205
FH20	206
FH21	206
FH22	187
FH26	185
FH27	185
FH28	185
FH29	185
FH30	176
FH31	177

GC

GC01	68
GC03	68
GC05	68
GC06	68
GC07	68
GC18	187
GC19	187
GC19B	187
GC20	310
GC20A	310
GC21	310
GC21A	310
GC24	310
GC25	310
GC25A	310
GC27	311
GC29	311
GC30	311
GC31	69
GC33	69
GC35	69
GC36	69
GC37	69
GC40	70
GC41	70
GC42L	70
GC42R	70
GC43	71
GC44	71

GG

GG01	54
GG02	54
GG03	54
GG06	153
GG06D	157
GG06EC	157
GG06 KIT	159
GG07	179
GG08	154
GG08-5	155
GG08-6U	155
GG08-8	155
GG08-9	155
GG08C	155
GG08-C	154
GG08-S	154
GG08-U	154
GG08 KIT	159
GG09	55
GG09-8	55
GG09-10	55
GG10	55
GG11	153
GG11A	156
GG11B	156
GG11EC	157
GG11 KIT	159
GG12	153
GG12 KIT	159
GG13	181
GG14	54
GG15	54
GG16	159
GG17	106
GG18	55
GG19	54
GG21	54
GGL	157
GGT	157
GGX	157
GGV2	312
GGV3	312

GM

GM01	228
GM01EC	228
GM01-12A	228
GM01-12B	228
GM01-12C	228
GM01-16A	228
GM01-16B	228
GM01-16C	228
GM01-20A	228
GM01-20B	228
GM01-20C	228
GM01A	230
GM01A-10A	230
GM01A-10C	230
GM01A-12A	230
GM01A-12C	230
GM01AEC	230
GM01SEC	234
GM01SF-12	228
GM01SF-16	228
GM01SF-20	228
GM01-S	236
GM02SF-10	230
GM02SF-12	230
GM03	232
GM03EC	232
GM04	248
GM04EC	248
GM05	256
GM05-8	256
GM05A	256
GM05B	256
GM06	250
GM06EC	250

GM

GM07	252
GM07EC	252
GM08	238
GM08EC	238
GM09	258
GM09EC	258
GM10	234
GM10-5	234
GM10-20A	234
GM10EC	234
GM11	240
GM11B	240
GM11EC	240
GM11SF	240
GM11-2	240
GM11-12	240
GM11-16	240
GM11-20	240
GM12	242
GM12EC	242
GM12-5	242
GM12-20	242
GM12-24	242
GM13	244
GM13EC	244
GM14	254
GM14EC	254

GT

GT01	48
GT02	45
GT04	109
GT04EC	157
GT05	109
GT06	109
GT07	43
GT09	150
GT09 KIT	158
GT10	150
GT10 KIT	158
GT11	150
GT11B	151
GT11 KIT	158
GT12	151
GT12 KIT	158
GT13	151
GT13 KIT	158
GT14	162
GT14-2	165
GT14A KIT	162
GT14B KIT	162
GT14-DL	164
GT14-DL2	164
GT14-H	167
GT16-1	167
GT16-2	167
GT16-4	167
GT16-5	167
GT21	204
GT22	204
GT22L	204
GT22T	204
GT24	162
GT24-DL	166
GT24-DL2	166
GT24-DL3	166
GT24-H	167
GT31	106
GT31-3	106
GT31EC-L	157
GT31EC-R	157
GT34	168
GT60	152
GT60 KIT	158
GTA	156
GTB	156
GTC	156
GTD	156
GTZ	156

HD

HD01	194
HD03	194
HD06	196
HD06A	196
HD13	195
HD14	197

HL

HL04	49
HL05	49
HL06	49
HL07	49
HL08	46
HL15	109
HL16	108
HL17	109
HL18	108
HL21	107
HL22	107
HL28	50
HL30	300
HL31	300
HL32	300
HL34	45
HL34A	46
HL35	46
HL36	52
HL37	52
HL38	52
HL39	45
HL40	46
HL43	50
HL44	52
HL45	51
HL47	52
HL48	43
HL49	43
HL50	43
HL51	51

HN

HN03	223
HN04	223
HN05	223

HR

HR01	308
HR02	308
HR03	308
HR04	308
HR05	308
HR06	308
HR07	308
HR08	308
HR09	309
HR10	309
HR12	309
HR13	309
HR18	309
HR20	309

HS

HS03	78
HS04	78
HS05	78
HS06	78
HS07	79
HS08	79
HS09	79
HS10	79

IC

IC01	204
IC02	204
IC03	204
IC04	204
IC05	204

KO

K002	272
K002-16A	272
K002A	272
K002A-16A	272
K002AEC	272
K002EC	272
K003A	272
K003A-16A	272
K003AEC	272
K004	272
K004-16A	272
K004EC	272
K005	272
K005EC	272

KP

KP01	187
KP02	207
KP03	187

KZ

KZ01	192
KZ02	192

LH

LH01	165
LH02	165

ML

ML01	192
ML03	192
ML05	206

MP

MP01	301
------	-----

PH

PH01	110
------	-----

RD

RD01	48
RD02	301

RH

RH01	48
RH03	107
RH08	108
RH09	108
RH12	205
RH18	45
RH18B	45
RH31	106

S

S01	57
S02	57
S04	57
S05	57
S06	57
S07	57
S08	57
S09	57
S10	57
S11	57
S12	57
S13	198
S14	198
S15	57
S16A	208
S17	198
S18	198
S19	56
S20	198
S21	56
S25	56
S26	56
S27	57
S28	57
S29	55
S30	56
S31	159
S31-12	159
S32	159
S33	159
S34	159
S36	56
S37	55

SD

SD01	220
SD01A	220
SD02A	220
SD02B	220
SD03	220
SD04	221
SD05	221
SD06	221
SD07	222
SD08	222

SH

SH01	61
SH03	61
SH05	61
SH06	61
SH07	61
SH17	65
SH18	65
SH20	67
SH31	60
SH33	60
SH35	60
SH36	60
SH37	60
SH45	64
SH46	64
SH47	65
SH48	65
SH49	62
SH50	62
SH51	62
SH52	63
SH53	63
SH54	63
SH55	66
SH56	66

WB

WB01	168
WB02	168

SP

SP01	49
SP03	107
SP06	108
SP10	191
SP10B	191
SP11	188
SP12	188
SP14	45
SP16	168

SS

SS01	224
SS02	224

TC

TC01	157
TC05	207
TC06	207
TC07	207

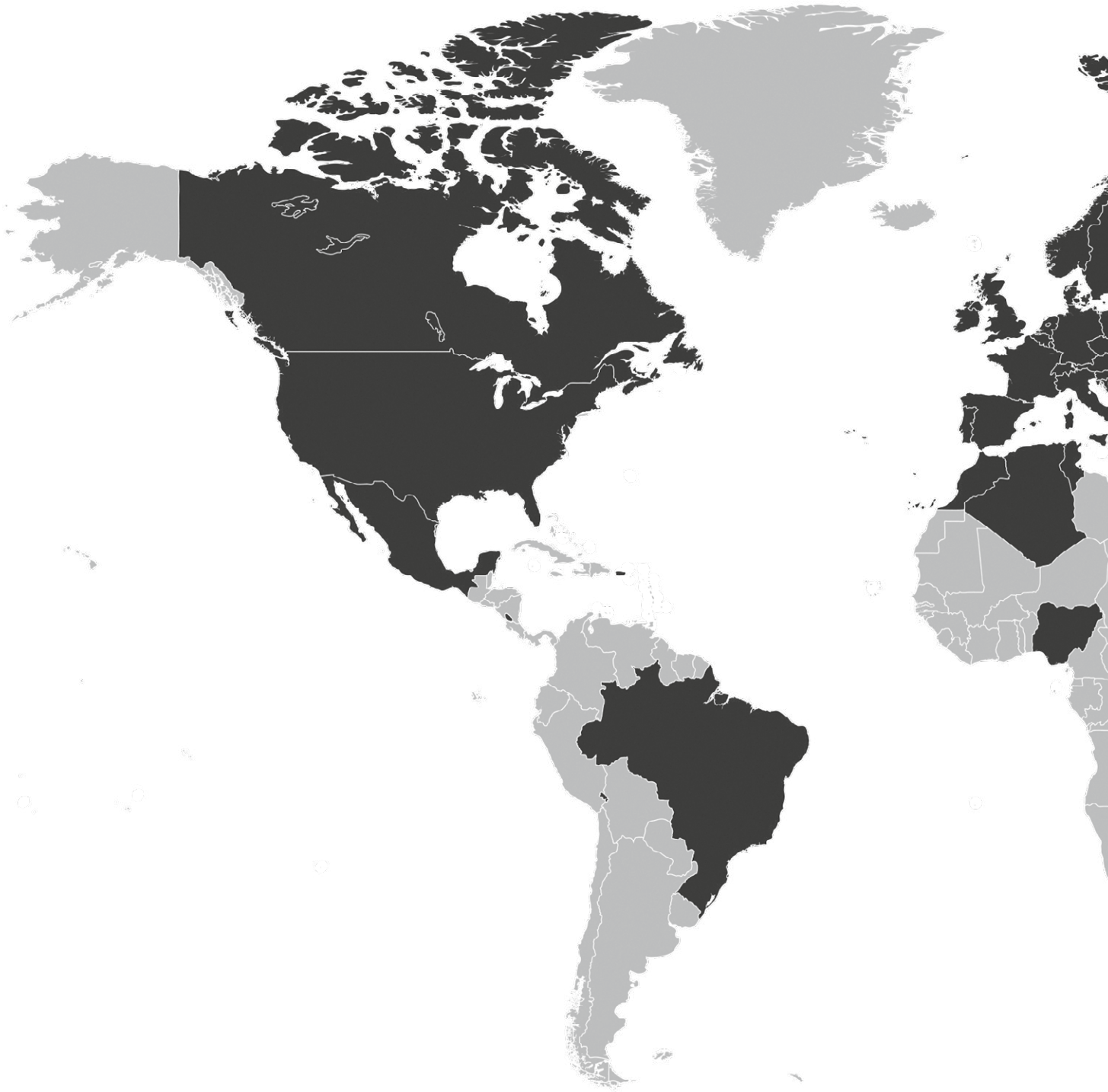

Exporting in more than 50 countries worldwide.

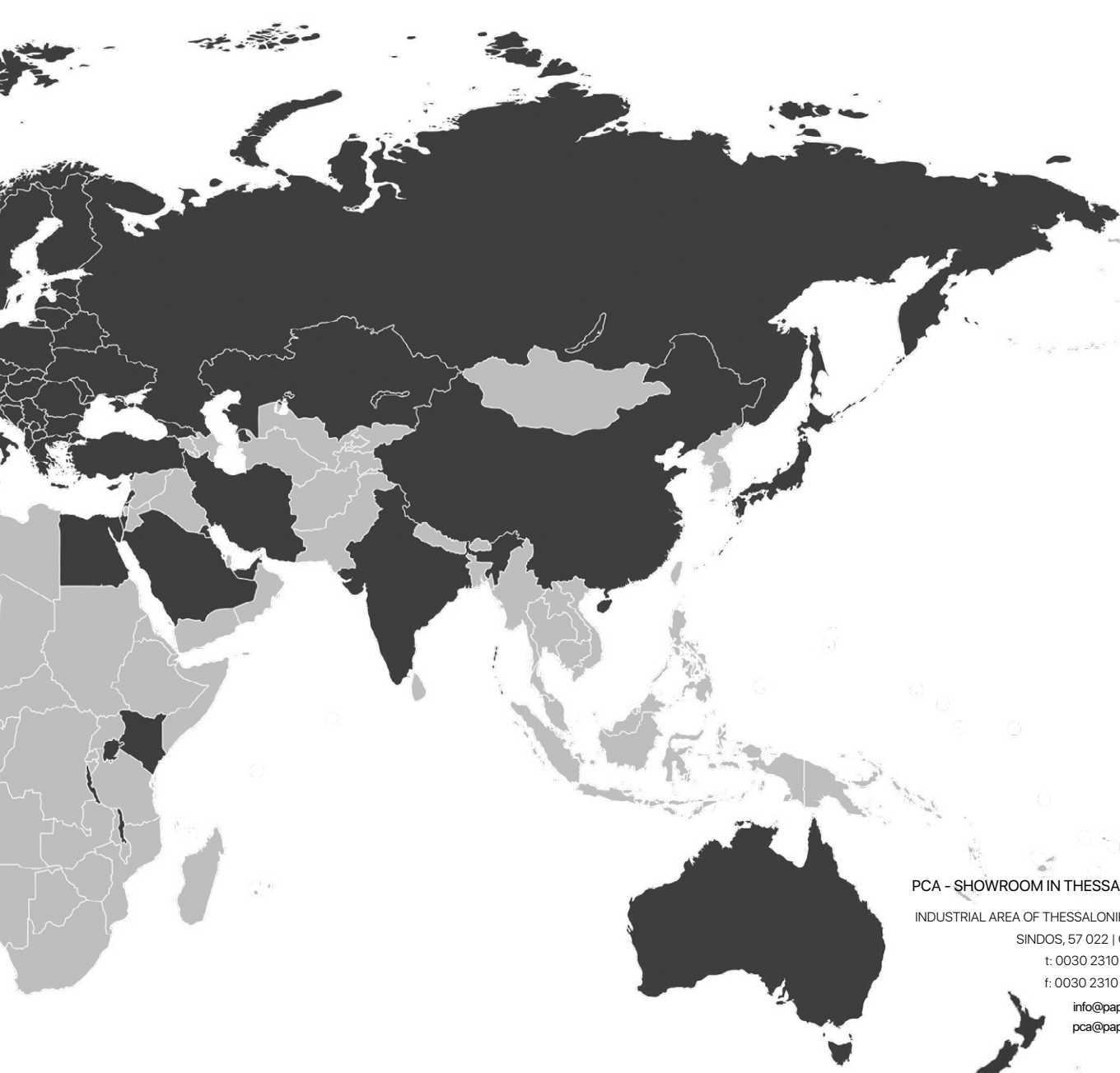

PCA - SHOWROOM IN THESSALONIKI

INDUSTRIAL AREA OF THESSALONIKI bk. 38

SINDOS, 57 022 | GREECE

t: 0030 2310 570727

f: 0030 2310 570726

info@papgroup.gr

pca@papgroup.gr

PAP SAFETY GLASS INDUSTRY

INDUSTRIAL AREA OF THESSALONIKI bk. 55

SINDOS, 57 022 | GREECE

t: 0030 2310 796180

f: 0030 2310 796179

psg@papgroup.gr

SHOWROOM IN ATHENS

SOLOMOU 13

PERISTERI-ATTIKI, 12133 | GREECE

t: 0030 210 5757 727

f: 0030 210 5757 727

pca@papgroup.gr



PCA owns a Research & Development department where innovative ideas and well studied designs come into realization, burdening the products with functionality and sophistication.

The core of our operations is the excellent and fast service of our customers worldwide.

www.papgroup.gr



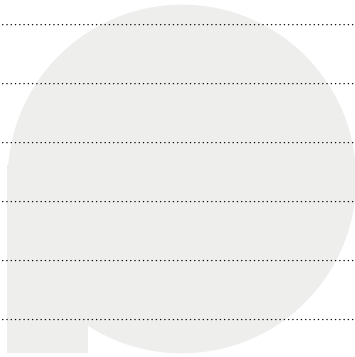

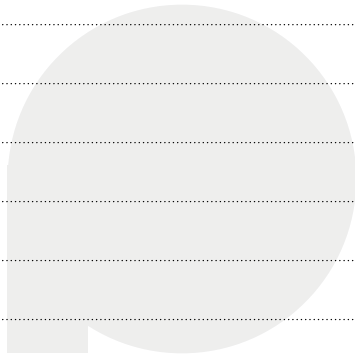

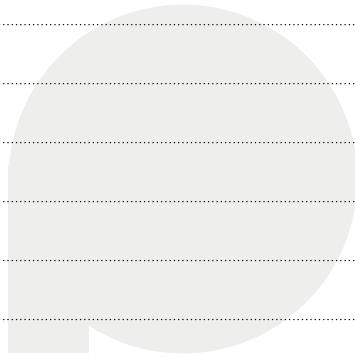

pca

PAPGROUP